



**GRAND VALLEY
STATE UNIVERSITY™**

**Grand Valley State University
Facilities Planning Department**

**SOIL EROSION AND SEDIMENTATION
CONTROL PROCEDURES MANUAL
DETAILS AND SPECIFICATIONS**

December 2018

ftc&h

Fishbeck, Thompson, Carr & Huber
engineers • scientists • architects • constructors



**GRAND VALLEY
STATE UNIVERSITY™**

**GRAND VALLEY STATE UNIVERSITY
FACILITIES PLANNING DEPARTMENT**

SOIL EROSION AND SEDIMENTATION CONTROL

PROCEDURES

**FOR USE BY GRAND VALLEY STATE UNIVERSITY
FACILITIES PLANNING DEPARTMENT
ADMINISTERING THE SOIL EROSION AND SEDIMENTATION CONTROL
PROGRAM
AS AUTHORIZED BY 1994 PA 451
AS APPROVED AUTHORIZED PUBLIC AGENCY (APA)**

**DECEMBER 2018
PROJECT NO. G110613**

TABLE OF CONTENTS



ACKNOWLEDGEMENTS	1
PREFACE	2
SESC DETAILS AND SPECIFICATIONS.....	2
SOIL EROSION AND SEDIMENTATION CONTROL PROCEDURES MANUAL.....	3
PROGRAM GUIDELINES.....	3
Introduction	3
GVSU, Historical SESC Project Information.....	3
GVSU, Authorized Public Agency (APA)	4
The GVSU SESC Program	5
TRAINING	6
SESC CERTIFICATION.....	6
PRINCIPLES OF SESC	6
REFERENCE STANDARDS.....	7
PLANNING AND DESIGN	7
CONSTRUCTION	8
INSPECTIONS	9
ENFORCEMENT	9
CONCLUSION	11

MICHIGAN SESC REGULATIONS

PART 91 - SOIL EROSION AND SEDIMENTATION CONTROL OF 1994 PA 451, THE NATURAL RESOURCES AND ENVIRONMENTAL PROTECTION ACT (NREPA), AS AMENDED

GRAND VALLEY STATE UNIVERSITY FACILITIES PLANNING DEPARTMENT SOIL EROSION AND SEDIMENTATION CONTROL (SESC) PROCEDURES

LIST OF APPENDICES

Appendix 1 Forms

- Authorization to Proceed with Earth Change form
- Soil Erosion and Sedimentation Control Inspection Report form
- Checklist for Contractor Soil Erosion and Sedimentation Control Plan
- Professional Services Contractor Soil Erosion and Sedimentation Control Design Checklist

Appendix 2 References to Part 91 SESC Regulations and Administrative Rules

Appendix 3 SESC Keying System

Appendix 4 Erosion Controls

Appendix 5 Erosion/Sediment Controls

Appendix 6 Sediment Controls

Appendix 7 Sample SESC Plan

Appendix 8 References

ACKNOWLEDGEMENTS

Special thanks to the following groups and individuals for their assistance in the compilation of this procedures manual:

State of Michigan

Department of Environmental Quality

Ms. Brandie Jacobs Stefanski

Erosion/Sedimentation Control and Construction Storm Water Program

Water Bureau

State of Michigan

Department of Management and Budget

Mr. Jason P. Nairn, CPESC

SESC Program Manager

DMB - Office of Facilities

Design and Construction Division

PREFACE

This procedures manual is intended to assist engineers, planners, and contractors in maintaining control of soil erosion and sedimentation on Grand Valley State University (GVSU) construction projects. Construction projects include building structures, as well as all earth change activities such as routine maintenance, landscaping, and land balancing.

This manual is a product of the commitment by GVSU to provide the highest quality construction projects without compromising Michigan's wealth of natural resources.

SESC DETAILS AND SPECIFICATIONS

The details and specifications contained within this manual are designed to provide standard guidelines for the design of soil erosion and sedimentation controls (SESC) into GVSU construction project drawings and specifications. It is intended that architects and engineers will have a standard set of detail and specification guidelines to incorporate as appropriate into earth change related project documents. It is important to note that many of the controls require engineering detail that is not provided within these guidelines. The design of the earth retention systems, basins, channels, and structures should be based on sound engineered solutions incorporating flow characteristics, soil characteristics, loads, drainage area, etc.

The layout of this document is intended to be simple and straightforward. The drawings indicate the basic layout and design of the most commonly used soil erosion and sediment controls used on GVSU projects. The specifications provide the important information that should accompany the design in an uncomplicated format. The "When" section discusses when the control should be considered for use at a particular site. The "Why" section provides a basic understanding of why the control is useful. The "Where" section provides information on the appropriate locations for the control. The "How" section provides detailed installation and removal information that will be useful as drawing notes or within specifications. Also included are special maintenance requirements and any limitations that should be considered.

SOIL EROSION AND SEDIMENTATION CONTROL PROCEDURES MANUAL

PROGRAM GUIDELINES

INTRODUCTION

Soil erosion is defined as the wearing away of land by the action of wind, water, or gravity, or a combination of wind, water, and gravity. The result of this wearing away of land is that soil particles are dislodged and put in motion. Soil particles that are in transport or have been transported to new locations and deposited are called sediment. The sedimentation of Michigan's water resources can adversely affect plant, animal, and aquatic life by altering the size or shape of streams, or covering the spawning habitat of aquatic species.

One way to combat sedimentation in Michigan's water resources is to control the erosion of soil particles from construction sites. Construction projects often require the removal of layers of vegetative cover in order to complete the construction of subgrade structural components or other foundational aspects of a project, thus increasing the likelihood of erosion. With proper design considerations and planning, soil erosion can be controlled such that sediment does not leave the site. Construction projects include building structures as well as all earth change activities such as routine maintenance, landscaping, and land balancing.

This procedures manual is designed to serve as a guidance document for GVSU consultants, contractors, and personnel who are involved in the design and construction of new and existing GVSU facilities. Within this document are items that must be considered in order to ensure that the proper measures are taken in the design and construction phases of projects to control the offsite migration of soil. In addition, sections of this procedures manual contain forms that will be used by GVSU consultants for the review of project documents and the inspection of construction sites for soil erosion and sedimentation control measures. The details and specifications section of the procedures manual contains SESC measures to be incorporated into the design of GVSU construction projects.

GVSU, HISTORICAL SESC PROJECT INFORMATION

In 2004, GVSU's President and Board of Trustees began requiring all new building facilities to be constructed to a minimum certification level of Silver under the U.S. Green Building Council's Leadership in Energy and Environmental Design (LEED) Rating System. This commitment to sustainable, energy efficient buildings has resulted in several certified buildings. An important aspect of these projects includes attention to building construction activities, including SESC measures as a prerequisite credit on all projects.

Part of the LEED Construction Activity Pollution Prevention credit requires project teams prepare a Storm Water Pollution Prevention Plan (SWPPP). The contents of the SWPPP are prepared and placed on display at the project site for the duration of the construction activities. The project civil engineer creates the SESC plan and technical specifications, which identify the erosion control measures required on the project. The schedule for construction activities is created prior to obtaining the soil erosion control permit, and updated during construction as required. Currently, all GVSU construction projects comply with the local erosion and sedimentation control standards and codes through the Ottawa County Drain Commissioner's Office, which is responsible for enforcement of the Soil Erosion and Sedimentation Control Act, Part 91 of P.A. 451, 1994 as amended. In addition, project teams obtain permit by rule (Rule 2190 of Part 31 of Act 451 - regulation regarding construction activities) coverage from the MDEQ for construction activities that disturb more than 5 acres. In accordance with the NPDES permit requirements, a storm water operator certified through the MDEQ is designated for each project. The operator is responsible for inspection of construction activity and maintaining a log of the inspections and necessary corrective actions. Based on project experiences and coordination with project architects/engineers and the local soil erosion authority, GVSU's Facilities Planning Department has extensive experience with SESC procedures and enforcement.

GVSU, AUTHORIZED PUBLIC AGENCY (APA)

GVSU accepts the responsibility for the control of erosion and sedimentation on projects for which they manage the construction. The GVSU Facilities Planning Department is the agency responsible for administering GVSU's SESC Program and has assigned the SESC Program responsibilities to two of the department's project managers who will be designated the Resident SESC Inspectors. The inspectors will be trained under Section 9123 of Part 91.

SESC will be a priority during and after all phases of construction. The designers, usually consulting architects and engineers, will develop a comprehensive SESC plan for each project incorporating, as appropriate, the SESC measures listed within this procedures manual. All SESC plans will be reviewed and approved by GVSU's Resident SESC Inspector prior to releasing the projects for bids. Where applicable, the GVSU Resident SESC Inspector will assist the project architect or engineer in developing the SESC plans. Following the award of a contract, the contractor shall prepare and issue for approval a "SESC Implementation Plan," which indicates the contractor's intended implementation of SESC on the project including a schedule and sequence. The GVSU Resident SESC Inspector, upon approval of the implementation plan, will issue to the contractor an "Authorization to Proceed with Earth Change" form, which is to be posted at the jobsite. SESC measures, including the approved construction contractor's implementation and sequencing plan, will be in place and functioning before the soil is disturbed or as specified in the construction schedule. All temporary control measures will remain in place and maintained until the impacted areas are permanently stabilized. The GVSU Resident SESC Inspector will notify Ottawa County of each proposed earth change under Rule 1706 (4).

GVSU performs in-house construction projects throughout the year. These projects are generally small and do not require permitting by local or state jurisdiction. They include general maintenance, landscaping or minor earth moving projects, and are performed by University personnel or contract personnel. The SESC plan development and implementation procedures for these projects will include checklist preparation by GVSU's Resident SESC Inspector and review of any required procedures with appropriate personnel performing the work. If construction activities or weather require additional SESC measures and procedures, the GVSU Resident SESC Inspector will enforce these requirements per their authority.

THE GVSU SESC PROGRAM

Pursuant to Part 91 of 1994 PA 451, SESC, GVSU has established SESC procedures to provide "effective SESC, inspection, enforcement, and sediment pollution abatement or prevention."

As an APA, GVSU is responsible for controlling erosion and offsite sedimentation on all GVSU construction projects. This responsibility cannot be transferred to the designer or contractor. However, their contracts can include penalties for non-compliance with SESC provisions that are included in the contract documents. Construction projects include building structures, as well as all earth change activities such as routine maintenance, landscaping, and land balancing.

To assist the GVSU Facilities Planning Department with ensuring compliance with Part 91 of 1994 PA 451, a separate SESC Program has been established within the department and Resident SESC Inspectors have been designated. The SESC program functions independent of the construction inspection services being provided by the GVSU Facilities Planning Department. To meet the professional and technical support needs of the SESC program, GVSU may contract with private consultants who have demonstrated the highest degree of expertise in this field.

The GVSU Resident SESC Inspectors responsible for projects required to comply with Part 91, are required to complete the Part 91 SESC training prior to their appointment. Individuals working for consultants, who provide design, review, and inspection services will be required to have completed Part 91 SESC training prior to performing work and shall provide evidence of their SESC certification.

TRAINING

SESC CERTIFICATION

Individuals with SESC decision making authority must complete the training required under Part 91 of 1994 PA 451, as amended. Information regarding SESC and storm water training can be obtained by going to www.michigan.gov/deg select "Land" and then select "Soil Erosion and Sedimentation Control."

PRINCIPLES OF SESC

GVSU recognized seven basic principles of erosion and sediment control. These principles will be implemented by GVSU, its project architects and engineers, and the SESC Program during the planning, design, and construction phases of all projects. The principles are:

1. Design and construct terrain features, such as slopes and drainage ways, to minimize the erosion potential of the exposed site based on the soil type, time of year, proximity to waterways, duration of exposure, length and steepness of the slope, and the anticipated volume and intensity of runoff.
2. Minimize the surface area of unstabilized soils left unprotected and vulnerable to runoff and wind at any one time.
3. Minimize the amount of time that unstabilized soil areas are exposed to erosive forces.
4. Protect and shield exposed soil areas with a cover of live vegetation, mulch, or other approved erosion resistant material during the temporary and permanent control periods of construction.
5. Avoid concentrating runoff. When concentrated runoff cannot be avoided, runoff velocities shall be reduced to non-erosive velocities.
6. Eroded sediments will be trapped onsite with temporary and permanent barriers, basins, or other sediment retention devices while allowing for the controlled discharge of runoff waters at non-erosive velocities.
7. Implement a continuous inspection and maintenance program.

REFERENCE STANDARDS

GVSU will comply with all requirements set forth in Part 91 of 1994 PA 451, as amended and the administrative rules promulgated under Part 91. SESC measures and standards shall comply with the *Grand Valley State University Facilities Planning Department Soil Erosion and Sedimentation Control Procedures Manual*. The SESC keying system referenced on construction drawings and specifications shall comply with the keying system located within this procedures manual. Other SESC measures may be used with the approval of GVSU.

PLANNING AND DESIGN

During the planning/design stage(s), each project will be evaluated to determine if Part 91 requirements are applicable. When the project involves an earth change, the GVSU Facilities Planning Department's Resident SESC Inspector and the project engineers or architects shall implement these procedures. For each project involving an earth change, potential SESC problem areas will be identified and a comprehensive SESC plan will be developed to minimize erosion and offsite sedimentation. The plan will show the quantity, type, and location of each control measure including construction sequencing, provide installation and maintenance schedules, and provide installation details or specifications. The plan or bid document will also provide for miscellaneous materials or quantities to address unanticipated control needs.

Design documents shall ensure permanent SESC measures are in place within five days of final grading (weather permitting). If it is not possible to permanently stabilize a disturbed area within five days of final grading, then temporary SESC measures shall be maintained until permanent measures are in place and the area is stabilized.

Seed and mulch will be widely used to provide temporary or permanent stabilization. Sod or other erosion resistant material, such as erosion control blankets will be used when seed and mulch is not appropriate, such as on slopes steeper than 1:3 (vertical: horizontal, rise over run).

Special attention will be given to ditches, swales, diversions, and other concentrated flow areas. These areas will be stabilized with erosion resistant materials, such as sod, erosion control blankets, turf reinforcement mats, or riprap, if erosive runoff velocities are anticipated. Check dams and sediment traps may be used in lieu of, or in conjunction with, the erosion resistant material to reduce runoff velocities and trap sediment.

All storm sewer inlets on and off the site impacted by the construction project will be protected with geosynthetic materials or inlet guards. Inlet sumps will be cleaned as necessary throughout the construction period and after project completion.

Special provisions will be included in the plans to control dust and minimize “tracking” of sediment onto adjacent streets. All sediment tracked or eroded onto the street will be promptly removed per scheduled street sweeping and/or as required by the Resident SESC Inspector.

Borrow and waste disposal areas will be identified, when possible, on the plan. The same consideration for controlling erosion and offsite sedimentation will apply to the borrow and waste disposal areas as applied to construction areas. When the contractor selects an offsite location for the borrow or waste disposal area, the contractor shall secure an SESC permit from the Part 91 County/Municipal Enforcing Agency. The GVSU Resident SESC Inspector is responsible to ensure that appropriate SESC measures are implemented for onsite activities. The contractor shall ensure that appropriate SESC measures are implemented when offsite areas are permitted by the Part 91 County/Municipal Enforcing Agency. The contractor shall provide to the GVSU Resident SESC Inspector a copy of the Part 91 permit received from the County/Municipal Enforcing Agency before any offsite earthwork commences.

The GVSU Resident SESC Inspector shall review the SESC plan to ensure they include, at a minimum, all information required in R323.1703 of Part 91.

The GVSU Resident SESC Inspector is responsible for reviewing and approving all SESC plans prepared by the professional service contractor and the construction sequencing of temporary measures submitted by the contractor.

CONSTRUCTION

All phases of construction and associated earthwork will be undertaken as scheduled and in accordance with the SESC Plan. The GVSU Resident SESC Inspector is responsible for ensuring that all SESC measures are properly installed in a timely manner (per drawings), maintained, and are effectively controlling erosion and offsite sedimentation. For projects involving minor earth changes with little or no potential for offsite sedimentation, GVSU’s Resident SESC Inspector will perform inspections or delegate the inspection responsibilities to an SESC trained professional services contractor.

Based on site conditions, the SESC trained contractor or subcontractor may make “minor” adjustments to the overall SESC plan such as relocating or adding silt fence, check dams, or modifying inlet protection controls. The minimum requirements of the SESC plan are identified in the *Checklist for Contractor’s Soil Erosion and Sedimentation Control Implementation Plan* in Section 1. If there are any “major” deviations from the SESC plan requirements, especially in areas with concentrated flows (except check dams), the professional service contractor must prepare and submit a revised SESC plan to the GVSU Resident SESC Inspector for review and approval prior to implementation. Prior review and approval is not required if the changes are needed to mitigate the effects of a pending sediment release.

Upon approval of the contractor's SESC plan, the GVSU Resident SESC Inspector will issue an "Authorization to Proceed with Earth Change" form to be posted at the jobsite for regulator review.

INSPECTIONS

Regular and post-rain event inspections will be conducted by GVSU's Resident SESC Inspector. Project contractors will continuously monitor the project site and adjacent areas for ineffective SESC measures. At least weekly and after every significant rain (runoff leaves the site) the GVSU Resident SESC inspector, or project's licensed Storm Water Operator, accompanied by a contractor's representative, will inspect all SESC measures on and off the site and document his/her observations on a "SESC Inspection Report Form" (Section 1) developed by GVSU. The inspection report shall document, at a minimum, the following:

1. Date of inspection
2. Name of inspector
3. Name of company representative
4. General weather conditions within last 48 hours
5. Is there a potential for sediment leaving the site?
6. Has sediment left the site since the last report? (explain in detail)
7. SESC Measures:
 - a. Are control measures installed per plan?
 - b. Are the control measures effective?
 - c. Do the control measures require maintenance?
8. Necessary corrective actions and information regarding who was notified and time limits for compliance.

Corrective actions will be completed within 48 hours of discovery for routine maintenance items including, but not limited to, removing sediment from behind silt fences or check dams, replacing or adding silt fence, seeding and mulching small areas, and street sweeping. Other necessary maintenance or corrective actions will be completed as soon as possible, but never more than five days after detection.

Special Note: If sediment is impacting lakes, streams, or wetlands, or there is a potential for sediment to impact lakes, streams, and wetlands, corrective actions will be completed within 24 hours.

A standard inspection report for SESC is included in Section 1 of this procedures manual.

ENFORCEMENT

Schedule of values for construction shall include separate line items for the sequencing of construction, installation, maintenance, and removal of temporary SESC measures, and installation and maintenance

of permanent SESC measures. The GVSU Resident SESC Inspectors shall review and approve any payment application where the contractor is invoicing for SESC work performed. This will provide GVSU a tool to hold monies if the controls are not installed, maintained, or removed in a timely manner as required by the contract documents. If the contractor fails to install, maintain, or remove the controls, GVSU, with proper notification (outlined below), shall consider stopping work or directing the work to another company and paying with the monies identified in the schedule of values. In the event the cost to remediate exceeds the contracted amount, the original bonding company shall be contacted regarding the shortfall.

Construction contracts, especially those with performance bonds, shall contain language that **allows GVSU to impose fines of at least \$500 per day** and assess actual damage costs if the contractor refuses to comply with SESC requirements and corrective measures contained in the construction contract. For bonded projects, the surety company shall be held responsible for these costs in the event the contractor refuses to perform or is found to be in default.

Enforcement actions are as follows:

1. The GVSU Resident SESC Inspector inspects and documents SESC measures and effectiveness using the “SESC Inspection Report Form.” Copies are distributed to the architect/engineer and GVSU Facilities Planning Department Project Manager.
2. If SESC measures are observed to be ineffective, the GVSU Resident SESC Inspector shall verbally direct the contractor to take appropriate corrective measures and document the action taken. Within 24 hours of issuing the verbal directions, written documentation shall be provided to the contractor. **NOTE:** The GVSU Resident SESC Inspector is empowered to direct the contractor to perform SESC corrective measures!
3. Within 48 hours (24 hours if impacting lakes, streams, or wetlands) of discovery and verbal notification, the contractor shall implement remedial actions. The GVSU Resident SESC Inspector shall provide written documentation to the assigned GVSU Project Manager that corrective measures have been implemented by the contractor.
4. If the contractor fails to implement remedial actions within the specified time, the GVSU Resident SESC Inspector shall provide written notice, sent certified mail, of “Notice of Noncompliance with Part 91 of 1994 PA 451.” This notification will outline fines and penalties to be imposed if corrective actions are not undertaken within a specified period of time (time is dependent upon nature of the severity of violation).
5. For a bonded project, the surety company shall be notified by a certified copy of the “Notice of Noncompliance.”

6. Continued in-action (after a second notice regarding the same issue) by the contractor shall result in the GVSU Resident SESC Inspector issuing a “Stop Work Order.” This order shall specifically identify where work is to cease, and identify a specified period of time that will be granted to the contractor before a third party contractor is hired by GVSU or the surety company to perform the required remediation (third party contracting by GVSU for SESC remediation shall be initiated through existing contracts or as an assignment depending on the severity and type of corrective actions needed).
7. Multiple “Notice of Noncompliance” citations (more than three for the same issue) will result in the GVSU Facilities Planning Department initiating actions to terminate the contract for “material breach.”

CONCLUSION

The GVSU Facilities Planning Department is prepared to provide technical support and inspection assistance on any GVSU project where assistance is required. The SESC program staff is:

- 1 - GVSU Facilities Planning Project Manager, as primary Resident SESC Inspector
- 2 - GVSU Facilities Planning Project Manager, as assistant Resident SESC Inspector

Should anyone have questions regarding the contents of this procedures manual or the procedures associated with the incorporation of SESC measures into GVSU projects, please contact the GVSU Facilities Planning Department.

Appendix 1

**Checklist for Contractor Soil Erosion
and Sedimentation Control Plan**

CHECKLIST FOR CONTRACTOR'S SOIL EROSION AND SEDIMENTATION CONTROL PLAN

For projects that include earth changes or disturb existing vegetation.

GRAND VALLEY STATE UNIVERSITY
FACILITIES PLANNING DEPARTMENT
SOIL EROSION AND SEDIMENTATION CONTROL PROGRAM

PROJECT TITLE: _____

PROJECT LOCATION: _____

PROJECT FILE NUMBER: _____

INDEX NUMBER: _____

Prior to the start of earthwork, the Contractor must submit a Soil Erosion and Sedimentation Control (SESC) Plan to the Grand Valley State University Facilities Planning Department. The intent of the SESC Plan is to ensure that the Contractor has reviewed and understands the SESC provisions within the drawings and specifications. The following checklist will provide Contractors with assistance in creating the SESC Plan.

The SESC Plan must include:

1. A written plan or letter demonstrating:
 - The Contractor's means and methods for the implementation of SESC provisions included within the plans and specifications and compliance with the provisions of Part 91 of PA 451 of 1994, as amended
 - The Contractors plan for dust control
 - The Contractor's plan for inspection and maintenance of temporary soil erosion and sedimentation control measures

2. A map, location plan, drawing, or amended copy of the project SESC provisions or grading plan showing:
 - The locations of any stockpiles of soil associated with the project
 - The temporary SESC control measures associated with stockpiles of soil
 - The Contractor's suggested or proposed additions or relocations of any temporary or permanent SESC control measures associated with the project drawings and specifications
 - Location of site entrances, exits and vehicle routes
 - Location of site superintendent's / project manager's site trailer or office (for SESC Inspector check-in)

3. A schedule for the installation and removal of temporary control measures and the installation of permanent soil erosion and sedimentation control measures in relation to the overall construction schedule.

Submit the above items to: Grand Valley State University
Facilities Planning Department - Resident SESC Inspector
1 Campus Drive
1201 Service Building
Allendale, MI 49401-9403

Upon approval of the Contractor's SESC Plan, an "Authorization to Proceed with Earth Change" will be issued by the Grand Valley State University Facilities Planning Department.

**“Authorization to Proceed with Earth Change”
Form**

AUTHORIZATION TO PROCEED WITH EARTH CHANGE

For projects that include earth changes or disturb existing vegetation.

GRAND VALLEY STATE UNIVERSITY
FACILITIES PLANNING DEPARTMENT
SOIL EROSION AND SEDIMENTATION CONTROL PROGRAM

SESC AUTHORIZATION NO.
<i>(OFFICE USE ONLY)</i>

CONTRACTOR NAME				DATE
CONTRACTOR MAILING ADDRESS				
PROJECT NAME				
INDEX NUMBER(S)	AGENCY NUMBER	FILE NUMBER	CONTRACT NUMBER	DEPARTMENT/UNIVERSITY/COLLEGE
DDESIGN PROFESSIONAL				NPDES PERMIT NO.

The Grand Valley State University (GVSU) Facilities Planning Department has received a copy of a Soil Erosion and Sedimentation Control (SESC) Plan for the above-referenced project. GVSU is authorized under Part 91, SESC, of 1994 PA 451, as amended to enforce soil erosion and sedimentation control requirements with regard to earth changes associated with GVSU managed projects.

The SESC Plan submitted for the above referenced project has been reviewed and authorization to proceed with the earth change is hereby:

- Approved.
- Approved subject to the following:

- Disapproved due to the following:

Signature of SESC Program Manager

Date

Authorization Number: _____

GENERAL CONDITIONS

In accordance with Rule 1709 promulgated under the authority of Part 91, Soil Erosion and Sedimentation Control, of the Natural Resources and Environmental Protection Act, 1994 PA 451, as amended, and in addition to the information on the attached plan(s) and special condition, the following general conditions apply to the earth change authorized by this document:

- Design, construct, and complete the earth change in a manner that limits the exposed area of disturbed land for the shortest period of time.
- Remove sediment caused by accelerated soil erosion from runoff water before it leaves the site of the earth change.
- Temporary or permanent control measures shall be designed and installed to convey water around, through, or from the earth change at a non-erosive velocity.
- Install temporary soil erosion and sedimentation control measures before or upon commencement of the earth change activity and maintain the measures on a daily basis. Remove temporary soil erosion and sedimentation control measures after permanent soil erosion measures are in place and the area is stabilized. (“Stabilized” means the establishment of vegetation or the proper placement, grading or covering of soil to ensure its resistance to soil erosion, sliding or other earth movement.)
- Complete permanent soil erosion control measures for the earth change within five calendar days after final grading or upon completion of the final earth change. If it is not possible to permanently stabilize the earth change, then maintain temporary soil erosion and sedimentation control measures until permanent soil erosion control measures are in place and the area is stabilized.

THIS AUTHORIZATION MUST BE POSTED AT THE PROJECT SITE.

Professional Service Contractor Soil Erosion and Sedimentation Control Design Checklist

- * - Soil erosion and sedimentation control measures may still be required even if the area of earth disturbance is less than one acre. Incorporate the components of the plan required to ensure that no sediment leaves the project site.

PROFESSIONAL SERVICES CONTRACTOR SOIL EROSION AND SEDIMENTATION CONTROL DESIGN CHECKLIST

GRAND VALLEY STATE UNIVERSITY
FACILITIES PLANNING DEPARTMENT
SOIL EROSION AND SEDIMENTATION CONTROL PROGRAM

PROJECT TITLE: _____

PROJECT LOCATION: _____

PROJECT FILE NUMBER: _____

INDEX NUMBER: _____

Y N*

Will this project include disturbing earth?

Estimate the areas (in acres) of disturbed earth: _____ acres.

Y N

Will this project disturb 1 or more acres?

Is this project within 500 feet of a lake, stream or wetland?

If earth change disturbs 1 or more acres or is within 500 feet of a lake, stream or wetland, please complete the remainder of this form.

Y N

Does this plan identify:

a. Project location

b. Distance to lakes , streams & wetlands

c. Soil type

d. Existing & final contours

e. Existing, construction & final drainage patterns (including dewatering facilities)

f. Limits of proposed earth change

g. Site boundaries / property lines

h. Schedule/ phasing of construction and installation of SESC control measures

i. Location of temporary (during construction) SESC control measures

j. Location of permanent (post construction) SESC control measures

k. Provisions for maintenance of temporary controls

l. A manual for owner maintenance of the permanent controls

* - Soil erosion and sedimentation control measures may still be required even if the area of earth disturbance is less than one acre. Incorporate the components of the plan required to ensure that no sediment leaves the project site.

PROJECT TITLE: _____

PROJECT LOCATION: _____

PROJECT FILE NUMBER: _____ **INDEX NUMBER:** _____

Y N

m. Details for installing and removing SESC control measures

Y N **Does the project specification include:**

a. Detail SESC requirements (Reference to Part 91 without detail is not acceptable)

b. Require the contractor to prepare and submit a construction sequence and SESC plan **before construction begins**

c. Line item on bid form for: a) construction sequencing, b) installation, maintenance and removal of temporary SESC control measures and c) installation and maintenance of permanent SESC control measures.

d. Constructing and maintaining temporary and permanent SESC measures

e. Language addressing \$500 per day fines and assessment of actual damage costs

Y N **Do the plans consider:**

a. Protection of the construction boundary perimeter

b. Protection of exposed soil and stockpiles from wind and water erosion

c. Protection of wetlands, streams and lakes

d. Inlet protection of storm water systems

e. Protection of exposed slopes from wind and water erosion

f. Vehicular tracking of soil off-site and street sweeping

Y N **Do the plans follow the seven basic principles of SESC?**

a. Design and construct terrain features such as slopes and drainage ways to minimize the erosion potential of the exposed site based on the soil type, time of year, proximity to waterways, duration of exposure and the anticipated volume and intensity of runoff.

b. Minimize the surface area of unstabilized soils left unprotected and vulnerable to runoff and wind erosion.

c. Minimize the time that unstabilized soil areas are exposed to erosive forces (wind and rain).

PROJECT TITLE: _____

PROJECT LOCATION: _____

PROJECT FILE NUMBER: _____ **INDEX NUMBER:** _____

Y N

- d. Protect and shield exposed soil areas with a cover of live vegetation, mulch, or other approved erosion resistant materials during the temporary and permanent control periods of construction.
- e. Avoid concentrated runoff, or when unavoidable, control runoff velocities to non-erosive levels.
- f. Eroded sediments will be trapped on-site with temporary and permanent barriers, basins or other sedimentation retention devices while allowing for the controlled discharge of runoff water at non-erosive velocities.
- g. Implement continuous inspection and maintenance programs.

Y N When site exceeds 1 acre, provide Storm Water Run-off information.

- a. Do the plans provide information regarding run-off volume, run-off velocities and peak discharges.
- b. Calculations are based on the 10, 25, or 100 year storm event.
- c. Identify method of calculating run- off volume, run-off velocity and peak discharge.

**Soil Erosion and Sedimentation Control
Inspection Report Form**

SOIL EROSION AND SEDIMENTATION CONTROL (SESC) INSPECTION REPORT

GRAND VALLEY STATE UNIVERSITY
FACILITIES PLANNING DEPARTMENT

This report is required to document soil erosion and sedimentation control on GVSU projects. (Authority: Part 91, PA 451)

REPORT NUMBER	SESC PERMIT NUMBER	REPORT DATE		PERIOD (FROM WHEN - TO WHEN)
INDEX NUMBER(S)	AGENCY NUMBER	FILE NUMBER	CONTRACT NUMBER	DEPARTMENT/UNIVERSITY/COLLEGE
PROJECT NAME				
CONTRACTOR				
PROFESSIONAL				

A. REASON FOR INSPECTION: Regular Inspection Post-Rain Event Inspection (explain below)

Weekly Daily

B. CURRENT WEATHER CONDITIONS:

Sunny Cloudy Partly Cloudy Windy Temperature _____

Precipitation: Rain Snow Sleet Hail Other (explain) _____

C. DESCRIBE SEVERE WEATHER (if applicable):

D. DESCRIBE WEATHER CONDITIONS SINCE LAST INSPECTION (Date of Last Inspection _____):

E. ARE THE CONTROLS INSTALLED ACCORDING TO THE PLANS AND SPECIFICATIONS? Yes No (Describe):

F. ARE THE CONTROLS IN PLACE FUNCTIONING PROPERLY? Yes No (Describe):

G. ARE THE CONTROLS BEING PROPERLY MAINTAINED? Yes No (Describe):

H. INDICATE THE SESC CONTROLS IN PLACE ON SITE (According to the DMB SESC Keying System):

SESC Measure	Present (check)	Number or Lineal Ft of Controls	SESC Measures	Present (check)	Number or Lineal Ft of Controls
Erosion Controls:			Erosion/Sediment Controls:		
(E1) Selective Grading & Shaping	<input type="checkbox"/>	_____	(ES31) Check Dam	<input type="checkbox"/>	_____
(E2) Grubbing Omitted	<input type="checkbox"/>	_____	(ES32) Stone Filter Berm	<input type="checkbox"/>	_____
(E3) Slope Roughening & Scarification	<input type="checkbox"/>	_____	(ES33) Filter Rolls	<input type="checkbox"/>	_____
(E4) Terraces	<input type="checkbox"/>	_____	(ES34) Sand Fence	<input type="checkbox"/>	_____
(E5) Dust Control	<input type="checkbox"/>	_____	(ES35) Dewatering	<input type="checkbox"/>	_____
(E6) Mulch	<input type="checkbox"/>	_____	(ES36) Diversion Dike/Berm	<input type="checkbox"/>	_____
(E7) Temporary Seeding	<input type="checkbox"/>	_____	(ES37) Diversion Ditch	<input type="checkbox"/>	_____
(E8) Permanent Seeding	<input type="checkbox"/>	_____	(ES38) Cofferdam/Sheet Pilings	<input type="checkbox"/>	_____
(E9) Mulch Blankets	<input type="checkbox"/>	_____	(ES39) Streambank Biostabilization	<input type="checkbox"/>	_____
(E10) Sodding	<input type="checkbox"/>	_____	(ES40) Polymers	<input type="checkbox"/>	_____
(E11) Vegetated Channels	<input type="checkbox"/>	_____	(ES41) Wattles	<input type="checkbox"/>	_____
(E12) Rip Rap	<input type="checkbox"/>	_____	Sediment Controls:		
(E13) Gabion Walls	<input type="checkbox"/>	_____	(S51) Silt Fence	<input type="checkbox"/>	_____
(E14) Energy Dissipator	<input type="checkbox"/>	_____	(S52) Catch Basin Sediment Guard	<input type="checkbox"/>	_____
(E15) Temporary Slope Drain	<input type="checkbox"/>	_____	(S53) Stabilized Construction Access	<input type="checkbox"/>	_____
(E16) Slope Drain	<input type="checkbox"/>	_____	(S54) Tire Wash	<input type="checkbox"/>	_____
(E17) Cellular Confinement Systems	<input type="checkbox"/>	_____	(S55) Sediment Basin	<input type="checkbox"/>	_____
(E18) Plastic Sheets	<input type="checkbox"/>	_____	(S56) Sediment Trap	<input type="checkbox"/>	_____
(E19) Temporary Drainageway/ Stream Crossing	<input type="checkbox"/>	_____	(S57) Vegetated Buffer/Filter Strip	<input type="checkbox"/>	_____
(E20) Temporary Bypass Channel	<input type="checkbox"/>	_____	(S58) Inlet Protection Fabric Drop	<input type="checkbox"/>	_____
(E21) Live Staking	<input type="checkbox"/>	_____	(S59) Inlet Protection Fabric Fence	<input type="checkbox"/>	_____
OTHER	<input type="checkbox"/>	_____	(S60) Inlet Protection Stone	<input type="checkbox"/>	_____

I. WHAT CORRECTIVE ACTIONS SHOULD BE TAKEN BY THE CONTRACTOR?

J. BY WHAT DATE MUST THESE ACTIONS BE IMPLEMENTED: _____

K. OBSERVATIONS / COMMENTS:

Signature of Inspector

Date

cc:

Appendix 2

GVSU SESC Appendix 2

A copy of Part 91 of 1994 PA 451 can be accessed by going to the MDEQ SESC website at

[http://www.legislature.mi.gov/\(S\(ugbyzcrefstwcb55dm5dv445\)\)/mileg.aspx?page=getobject&objectname=mcl-451-1994-ii-2-soil-conservation-erosion-and-sedimentation-control-91&highlight](http://www.legislature.mi.gov/(S(ugbyzcrefstwcb55dm5dv445))/mileg.aspx?page=getobject&objectname=mcl-451-1994-ii-2-soil-conservation-erosion-and-sedimentation-control-91&highlight)

A copy of the administrative rules are available at the MDEQ SESC website at

http://www.state.mi.us/orr/emi/admincode.asp?AdminCode=Single&Admin_Num=32301701.

**PART 91, SOIL EROSION AND SEDIMENTATION CONTROL
OF THE
NATURAL RESOURCES AND ENVIRONMENTAL PROTECTION ACT
1994 PA 451, AS AMENDED**

324.9101 Definitions; A to W.

Sec. 9101. (1) "Agricultural practices" means all land farming operations except the plowing or tilling of land for the purpose of crop production or the harvesting of crops.

(2) "Authorized public agency" means a state agency or an agency of a local unit of government authorized under section 9110 to implement soil erosion and sedimentation control procedures with regard to earth changes undertaken by it.

(3) "Conservation district" means a conservation district authorized under part 93.

(4) "Consultant" means either of the following:

(a) An individual who has a current certificate of training under section 9123.

(b) A person who employs 1 or more individuals who have current certificates of training under section 9123.

(5) "County agency" means an officer, board, commission, department, or other entity of county government.

(6) "County enforcing agency" means a county agency or a conservation district designated by a county board of commissioners under section 9105.

(7) "County program" or "county's program" means a soil erosion and sedimentation control program established under section 9105.

(8) "Department" means the department of environmental quality.

(9) "Earth change" means a human-made change in the natural cover or topography of land, including cut and fill activities, which may result in or contribute to soil erosion or sedimentation of the waters of the state. Earth change does not include the practice of plowing and tilling soil for the purpose of crop production.

(10) "Local ordinance" means an ordinance enacted by a local unit of government under this part providing for soil erosion and sedimentation control.

(11) "Municipal enforcing agency" means an agency designated by a municipality under section 9106 to enforce a local ordinance.

(12) "Municipality" means any of the following:

(a) A city.

(b) A village.

(c) A charter township.

(d) A general law township that is located in a county with a population of 200,000 or more.

(13) "Rules" means the rules promulgated pursuant to the administrative procedures act of 1969, 1969 PA 306, MCL 24.201 to 24.328.

(14) "Sediment" means solid particulate matter, including both mineral and organic matter, that is in suspension in water, is being transported, or has been removed from its site of origin by the actions of wind, water, or gravity and has been deposited elsewhere.

(15) "Soil erosion" means the wearing away of land by the action of wind, water, gravity, or a combination of wind, water, or gravity.

(16) "State agency" means a principal state department.

(17) "Violation of this part" or "violates this part" means a violation of this part, the rules promulgated under this part, a permit issued under this part, or a local ordinance enacted under this part.

(18) "Waters of the state" means the Great Lakes and their connecting waters, inland lakes and streams as defined in rules promulgated under this part, and wetlands regulated under part 303.

History: Add. 1995, Act 60, Imd. Eff. May 24, 1995;--Am. 2000, Act 504, Imd. Eff. Jan. 11, 2001.

324.9102, 324.9103 Repealed. 2000, Act 504, Imd. Eff. Jan. 11, 2001.

Compiler's Note: The repealed sections pertained to definitions and soil erosion and sedimentation control program.

324.9104 Rules; availability of information.

Sec. 9104. (1) The department, with the assistance of the department of agriculture, shall promulgate rules for a unified soil erosion and sedimentation control program, including provisions for the review and approval of site plans, land use plans, or permits relating to soil erosion control and sedimentation control. The department shall notify and make copies of proposed rules available to county enforcing agencies, municipal enforcing agencies, and authorized public agencies for review and comment before promulgation.

(2) The department shall make available to county enforcing agencies, municipal enforcing agencies, and authorized public agencies educational information on soil erosion and sedimentation control techniques and the benefits of implementing soil erosion and sedimentation control measures. County enforcing agencies and municipal enforcing agencies shall distribute this information to persons receiving permits under a county program or a local ordinance and to other interested persons.

History: Add. 1995, Act 60, Imd. Eff. May 24, 1995;--Am. 2000, Act 504, Imd. Eff. Jan. 11, 2001.

324.9105 Administration and enforcement of rules; resolution; ordinance; interlocal agreement; review; notice of results; informal meeting; probation; consultant; inspection fees; rescission of order, stipulation, or probation.

Sec. 9105. (1) Subject to subsection (6), a county is responsible for the administration and enforcement of this part and the rules promulgated under this part throughout the county except as follows:

(a) Within a municipality that has assumed the responsibility for soil erosion and sedimentation control under section 9106.

(b) With regard to earth changes of authorized public agencies.

(2) Subject to subsection (3), the county board of commissioners of each county, by resolution, shall designate a county agency, or a conservation district upon the concurrence of the conservation district, as the county enforcing agency responsible for administration and enforcement of this part and the rules promulgated under this part in the name of the county. The resolution may set forth a schedule of fees for inspections, plan reviews, and permits and may set forth other matters relating to the administration and enforcement of the county program and this part and the rules promulgated under this part.

(3) In lieu of or in addition to a resolution provided for in subsection (2), the county board of commissioners of a county may provide by ordinance for soil erosion and sedimentation control in the county. An ordinance adopted under this subsection may be more restrictive than, but shall not make lawful that which is unlawful under, this part and the rules promulgated under this part. If an ordinance adopted under this subsection is more restrictive than this part and the rules promulgated under this part, the county enforcing agency shall notify a person receiving a permit under the ordinance that the ordinance is more restrictive than this part and the rules promulgated under this part. The ordinance shall incorporate by reference the rules promulgated under this part that do not conflict with a more restrictive ordinance and may set forth such other matters as the county board of commissioners considers necessary or desirable. The ordinance may provide penalties for a violation of the ordinance that are consistent with section 9121.

(4) A copy of a resolution or ordinance adopted under this section and all subsequent amendments to the resolution or ordinance shall be forwarded to the department for the department's review and approval. The department shall forward a copy to the conservation district for that county for review and comment. Not later than December 31, 2001, the department shall prepare and submit a report to the standing committees of the senate and the house of representatives with jurisdiction over issues primarily related to natural resources and the environment. This report shall detail the number and the substance of complaints that have been received by the department related to county ordinances that have been adopted under subsection (3) that are more restrictive than this part and the rules promulgated under this part.

(5) Two or more counties may provide for joint enforcement and administration of this part and the rules promulgated under this part by entering into an interlocal agreement pursuant to the urban cooperation act of 1967, 1967 (Ex Sess) PA 7, MCL 124.501 to 124.512.

(6) Within 3 years after the effective date of the amendatory act that added this subsection, the department shall conduct an initial review of each county's soil erosion and sedimentation control program in accordance with a schedule established by the department. If the department approves a county program, its approval is valid for a 5-year period. After the initial review, the department shall conduct a review of a county's program every 5 years. The review shall be conducted at least 6 months before the expiration of each succeeding 5-year period. The department shall approve a county's program if all of the following conditions are met:

(a) The county has passed a resolution or enacted an ordinance as provided in this section.

(b) The individuals with decision-making authority who are responsible for administering the county program have current certificates of training under section 9123.

(c) The county has effectively administered and enforced the county program in the past 5 years or has implemented changes in its administration or enforcement procedures that the department determines will result in the county effectively administering and enforcing the county program. In determining whether the county has met the requirement of this subdivision, the department shall consider all of the following:

- (i) Whether a mechanism is in place to provide funding to administer the county's program.
- (ii) Whether the county has conducted adequate inspections to assure minimization of soil erosion and off-site sedimentation.
- (iii) The effectiveness of the county's past compliance and enforcement efforts.
- (iv) The adequacy and effectiveness of the applications and soil erosion and sedimentation control plans being accepted by the county.
- (v) The adequacy and effectiveness of the permits issued by the county and the inspections being performed by the county.
- (vi) The conditions at construction sites under the jurisdiction of the county as documented by departmental inspections.

(7) Following a review under subsection (6), the department shall notify the county of the results of its review and whether the department proposes to approve or disapprove the county's program. Within 30 days of receipt of the notice under this subsection, a county may request and the department shall hold an informal meeting to discuss the review and the proposed action by the department.

(8) Following the meeting under subsection (7), if requested, and consideration of the review under subsection (6), if the department does not approve a county's program, the department shall enter an order, stipulation, or consent agreement under section 9112(2) placing the county on probation. In addition, at any time that the department determines that a county that was previously approved by the department under subsection (6) is not satisfactorily administering and enforcing the county's program, the department shall enter into an order, stipulation, or consent agreement under section 9112(2) placing the county on probation. During the 6-month period after a county is placed on probation, the department shall consult with the county on how the county could change its administration of the county program in a manner that would result in its approval.

(9) Within 6 months after a county has been placed on probation under subsection (8), the county may notify the department that it intends to hire a consultant to administer the county's program. If, within 60 days after notifying the department, the county hires a consultant that is acceptable to the department, then within 1 year after the county hires the consultant, the department shall conduct a review of the county's program to determine whether or not the county program can be approved.

(10) If any of the following occur, the department shall hire a consultant to administer the county's program:

- (a) The county does not notify the department of its intent to hire a consultant under subsection (9).
- (b) The county does not hire a consultant that is acceptable to the department within 60 days after notifying the department of its intent to hire a consultant under subsection (9).
- (c) The county remains unapproved following the department's review under subsection (9).

(11) Upon hiring a consultant under subsection (10), the department may establish a schedule of fees for inspections, review of soil erosion and sedimentation control plans, and permits for the county's program that will provide sufficient revenues to pay for the cost of the contract with the consultant, or the department may bill the county for the cost of the contract

with the consultant. As used in this subsection, “cost of the contract” means the actual cost of a contract with a consultant plus the documented costs to the department in administering the contract, but not to exceed 10% of the actual cost of the contract.

(12) At any time that a county is on probation as provided for in this section, the county may request the department to conduct a review of the county's program. If, upon such review, the county has implemented appropriate changes to the county's program, the department shall approve the county's program. If the department approves a county's program under this subsection, the department shall rescind its order, stipulation, or consent agreement that placed the county on probation.

History: Add. 1995, Act 60, Imd. Eff. May 24, 1995;--Am. 2000, Act 504, Imd. Eff. Jan. 11, 2001.

324.9106 Ordinances.

Sec. 9106. (1) Subject to subsection (3), a municipality by ordinance may provide for soil erosion and sedimentation control on public and private earth changes within its boundaries except that a township ordinance shall not be applicable within a village that has in effect such an ordinance. An ordinance may be more restrictive than, but shall not make lawful that which is unlawful under, this part and the rules promulgated under this part. If an ordinance adopted under this section is more restrictive than this part and the rules promulgated under this part, the municipal enforcing agency shall notify a person receiving a permit under the ordinance that the ordinance is more restrictive than this part and the rules promulgated under this part. The ordinance shall incorporate by reference the rules promulgated under this part that do not conflict with a more restrictive ordinance, shall designate a municipal enforcing agency responsible for administration and enforcement of the ordinance, and may set forth such other matters as the legislative body considers necessary or desirable. The ordinance shall be applicable and shall be enforced with regard to all private and public earth changes within the municipality except earth changes by an authorized public agency. The municipality may consult with a conservation district for assistance or advice in the preparation of the ordinance. The ordinance may provide penalties for a violation of the ordinance that are consistent with section 9121.

(2) An ordinance related to soil erosion and sedimentation control that is not approved by the department as conforming to the minimum requirements of this part and the rules promulgated under this part has no force or effect. A municipality shall submit a copy of its proposed ordinance or of a proposed amendment to its ordinance to the department for approval before adoption. The department shall forward a copy to the county enforcing agency of the county in which the municipality is located and the appropriate conservation district for review and comment. Within 90 days after the department receives an existing ordinance, proposed ordinance, or amendment, the department shall notify the clerk of the municipality of its approval or disapproval along with recommendations for revision if the ordinance, proposed ordinance, or amendment does not conform to the minimum requirements of this part or the rules promulgated under this part. If the department does not notify the clerk of the local unit within the 90-day period, the ordinance, proposed ordinance, or amendment shall be considered to have been approved by the department.

(3) After a date determined by a schedule established by the department, but not later than 3 years after the effective date of the amendatory act that added this subsection, a municipality shall not administer and enforce this part or the rules promulgated under this part or a local ordinance unless the department has approved the municipality. An approval under this section is valid for 5 years, after which the department shall review the municipality for reapproval. At least 6 months before the expiration of each succeeding 5-year approval period,

the department shall complete a review of the municipality for reapproval. The department shall approve a municipality if all of the following conditions are met:

(a) The municipality has enacted an ordinance as provided in this section that is at least as restrictive as this part and the rules promulgated under this part.

(b) The individuals with decision-making authority who are responsible for administering the soil erosion and sedimentation control program for the municipality have current certificates of training under section 9123.

(c) The municipality has submitted evidence of its ability to effectively administer and enforce a soil erosion and sedimentation control program. In determining whether the municipality has met the requirements of this subdivision, the department shall consider all of the following:

(i) Whether a mechanism is in place to provide funding to administer the municipality's soil erosion and sedimentation control program.

(ii) The adequacy of the documents proposed for use by the municipality including, but not limited to, application forms, soil erosion and sedimentation control plan requirements, permit forms, and inspection reports.

(iii) If the municipality has previously administered a soil erosion and sedimentation control program, whether the municipality effectively administered and enforced the program in the past or has implemented changes in its administration or enforcement procedures that the department determines will result in the municipality effectively administering and enforcing a soil erosion and sedimentation control program in compliance with this part and the rules promulgated under this part. In determining whether the municipality has met the requirement of this subparagraph, the department shall consider all of the following:

(A) Whether the municipality has had adequate funding to administer the municipality's soil erosion and sedimentation control program.

(B) Whether the municipality has conducted adequate inspections to assure minimization of soil erosion and off-site sedimentation.

(C) The effectiveness of the municipality's past compliance and enforcement efforts.

(D) The adequacy and effectiveness of the applications and soil erosion and sedimentation control plans being accepted by the municipality.

(E) The adequacy and effectiveness of the permits issued by the municipality and the inspections being performed by the municipality.

(F) The conditions at construction sites under the jurisdiction of the municipality as documented by departmental inspections.

(4) If the department determines that a municipality is not approved under subsection (3) or that a municipality that was previously approved under subsection (3) is not satisfactorily administering and enforcing this part and the rules promulgated under this part, the department shall enter an order, stipulation, or consent agreement under section 9112(2) denying the municipality authority or revoking the municipality's authority to administer a soil erosion and sedimentation control program. Upon entry of this order, stipulation, or consent agreement, the county program for the county in which the municipality is located becomes operative within the municipality.

(5) A municipality that elects to rescind its ordinance shall notify the department. Upon rescission of its ordinance, the county program for the county in which the municipality is located becomes operative within the municipality.

(6) A municipality that rescinds its ordinance or is not approved by the department to administer the program shall retain jurisdiction over projects under permit at that time. The municipality shall retain jurisdiction until the projects are completed and stabilized or the county agrees to assume jurisdiction over the permitted earth changes.

History: Add. 1995, Act 60, Imd. Eff. May 24, 1995;--Am. 2000, Act 504, Imd. Eff. Jan. 11, 2001.

324.9107 Notice of violation.

Sec. 9107. If a local unit of government has notice that a violation of this part has occurred within the boundaries of that local unit of government, including but not limited to a violation attributable to an earth change by an authorized public agency, the local unit of government shall notify the appropriate county enforcing agency and municipal enforcing agency and the department of the violation.

History: Add. 1995, Act 60, Imd. Eff. May 24, 1995;--Am. 2000, Act 504, Imd. Eff. Jan. 11, 2001.

324.9108 Permit; deposit as condition for issuance.

Sec. 9108. As a condition for the issuance of a permit, the county enforcing agency or municipal enforcing agency may require the applicant to deposit with the clerk of the county or municipality in the form of cash, a certified check, or an irrevocable bank letter of credit, whichever the applicant selects, or a surety bond acceptable to the legislative body of the county or municipality or to the county enforcing agency or municipal enforcing agency, in an amount sufficient to assure the installation and completion of such protective or corrective measures as may be required by the county enforcing agency or municipal enforcing agency.

History: Add. 1995, Act 60, Imd. Eff. May 24, 1995;--Am. 2000, Act 504, Imd. Eff. Jan. 11, 2001.

324.9109 Agreement between public agency or county or municipal enforcing agency and conservation district; purpose; reviews and evaluations of agency's programs or procedures; agreement between person engaged in agricultural practices and conservation district; notification; enforcement.

Sec. 9109. (1) An authorized public agency, county enforcing agency, or municipal enforcing agency may enter into an agreement with a conservation district for assistance and advice in overseeing and reviewing compliance with soil erosion and sedimentation control procedures and in reviewing existing or proposed earth changes, earth change plans, or site plans with regard to technical matters pertaining to soil erosion and sedimentation control. In addition to or in the absence of such agreements, conservation districts may perform periodic reviews and evaluations of the authorized public agency's, county enforcing agency's, or municipal enforcing agency's programs or procedures pursuant to standards and specifications developed in cooperation with the respective districts and as approved by the department. These reviews and evaluations shall be submitted to the department for appropriate action.

(2) A person engaged in agricultural practices may enter into an agreement with the appropriate conservation district to pursue agricultural practices in accordance with and subject to this part, the rules promulgated under this part, and any applicable local ordinance. If a person enters into an agreement with a conservation district, the conservation district shall notify the county enforcing agency or municipal enforcing agency or the department in writing of the agreement. Upon entering into the agreement under this subsection, a person is not subject to permits required under this part, but is required to develop project specific soil erosion and sedimentation control plans and is subject to the remedies provided for in this part for violations of this part.

History: Add. 1995, Act 60, Imd. Eff. May 24, 1995;--Am. 2000, Act 504, Imd. Eff. Jan. 11, 2001

324.9110 Designation as authorized public agency; application; submission of procedures; variance; approval.

Sec. 9110. (1) Subject to subsection (4), a state agency or an agency of a local unit of government may apply to the department for designation as an authorized public agency by submitting to the department the soil erosion and sedimentation control procedures governing all earth changes normally undertaken by the agency. If the applicant is an agency of a local unit of government, the department shall submit the procedures to the county enforcing agency and the appropriate conservation district for review. The county enforcing agency and the conservation district shall submit their comments on the procedures to the department within 60 days. If the applicant is a state agency, the department shall submit the procedures to the department of agriculture for review, and the department of agriculture shall submit its comments on the procedures to the department within 60 days.

(2) Subject to subsection (4), if the department finds that the soil erosion and sedimentation control procedures of the state agency or the agency of the local unit of government meet the requirements of this part and rules promulgated under this part, the department shall designate the agency as an authorized public agency.

(3) Subject to subsection (4), after approval of the procedures and designation as an authorized public agency pursuant to subsection (1) or (2), all earth changes maintained or undertaken by the authorized public agency shall be undertaken pursuant to the approved procedures. If determined necessary by the department and upon request of an authorized public agency, the department may grant a variance from the provisions of this subsection.

(4) After a date determined by a schedule established by the department, but not later than 3 years after the effective date of the amendatory act that added this subsection, a state agency or an agency of a local unit of government shall not administer and enforce this part and the rules promulgated under this part as an authorized public agency unless the department has approved the agency under this section. An approval under this section is valid for 5 years, after which the department shall review the agency for reapproval. At least 6 months before the expiration of each succeeding 5-year period, the department shall complete a review of the authorized public agency for reapproval. The department shall approve a state agency or an agency of a local unit of government if all of the following conditions are met:

(a) The agency has adopted soil erosion and sedimentation control procedures that are at least as restrictive as this part and the rules promulgated under this part.

(b) The individuals with decision-making authority who are responsible for administering the soil erosion and sedimentation control procedures have current certificates of training under section 9123.

(c) The agency has submitted evidence of its ability to effectively administer soil erosion and sedimentation control procedures. In determining whether the agency has met the requirement of this subdivision, the department shall consider all of the following:

(i) Funding to administer the agency's soil erosion and sedimentation control program.

(ii) The agency's plans for inspections to assure minimization of soil erosion and off-site sedimentation.

(iii) The adequacy of the agency's soil erosion and sedimentation control procedures.

(iv) If the agency has previously administered soil erosion and sedimentation control procedures, the agency has effectively administered these procedures or has implemented changes in their administration that the department determines will result in the agency effectively administering the soil erosion and sedimentation control procedures. In determining

whether the agency has met the requirement of this subparagraph, the department shall consider all of the following:

(A) Whether the agency has had adequate funding to administer the agency's soil erosion and sedimentation control program.

(B) Whether the agency has conducted adequate inspections to assure minimization of soil erosion and off-site sedimentation.

(C) The effectiveness of the agency's past compliance and enforcement efforts.

(D) The adequacy of the agency's soil erosion and sedimentation control plans and procedures as required by rule.

(E) The conditions at construction sites under the jurisdiction of the agency as documented by departmental inspections.

(5) If the department determines that a state agency or an agency of a local unit of government is not approved under subsection (4) or that a state agency or an agency of a local unit of government that was previously approved under subsection (4) is not satisfactorily administering and enforcing this part and the rules promulgated under this part, the department shall enter an order, stipulation, or consent agreement under section 9112(2) denying or revoking the designation of the state agency or agency of a local unit of government as an authorized public agency.

History: Add. 1995, Act 60, Imd. Eff. May 24, 1995--Am. 2000, Act 504, Imd. Eff. Jan. 11, 2001.

324.9111 Repealed. 2000, Act 504, Imd. Eff. Jan. 11, 2001.

Compiler's Note: The repealed section pertained to statements and certificates relating to plats.

324.9112 Earth change; permit required; violation; notice; hearing; answer; evidence; stipulation or consent order; final order of determination.

Sec. 9112. (1) A person shall not maintain or undertake an earth change governed by this part, the rules promulgated under this part, or an applicable local ordinance, except in accordance with this part and the rules promulgated under this part or with the applicable local ordinance, and pursuant to a permit approved by the appropriate county enforcing agency or municipal enforcing agency. A county enforcing agency or municipal enforcing agency shall approve or deny an application for a permit within 30 days after the filing of a complete application for a permit.

(2) If in the opinion of the department a person, including an authorized public agency, violates this part, the rules promulgated under this part, or an applicable local ordinance, or a county enforcing agency or municipal enforcing agency fails to enforce this part, the rules promulgated under this part, or an applicable local ordinance, the department may notify the alleged offender in writing of its determination. If the department places a county on probation under section 9105, a municipality is not approved under section 9106, or a state agency or agency of a local unit of government is not approved under section 9110, or if the department determines that a municipal enforcing agency or authorized public agency is not satisfactorily administering and enforcing this part and rules promulgated under this part, the department shall notify the county, municipality, state agency, or agency of a local unit of government in writing of its determination or action. The notice shall contain, in addition to a statement of the specific violation or failure that the department believes to exist, a proposed order, stipulation for agreement, or other action that the department considers appropriate to assure timely correction of the violation or failure. The notice shall set a date for a hearing not less than 4 nor more than 8 weeks from the date of the notice of determination. Extensions of the date of the hearing may be granted by the department or on request. At the hearing, any interested party may appear, present witnesses, and submit evidence. A person who has been served with a notice of

determination may file a written answer to the notice of determination before the date set for hearing or at the hearing may appear and present oral or written testimony and evidence on the charges and proposed requirements of the department to assure correction of the violation or failure. If a person served with the notice of determination agrees with the proposed requirements of the department and notifies the department of that agreement before the date set for the hearing, disposition of the case may be made with the approval of the department by stipulation or consent agreement without further hearing. The final order of determination following the hearing, or the stipulation or consent order as authorized by this section and approved by the department, is conclusive unless reviewed in accordance with the administrative procedures act of 1969, 1969 PA 306, MCL 24.201 to 24.328, in the circuit court of Ingham county, or of the county in which the violation occurred, upon petition filed within 15 days after the service upon the person of the final order of determination.

History: Add. 1995, Act 60, Imd. Eff. May 24, 1995;--Am. 2000, Act 504, Imd. Eff. Jan. 11, 2001.

324.9113 Injunction; inspection and investigation.

Sec. 9113. (1) Notwithstanding the existence or pursuit of any other remedy, the department or a county enforcing agency or municipal enforcing agency may maintain an action in its own name in a court of competent jurisdiction for an injunction or other process against a person to restrain or prevent violations of this part.

(2) An agent appointed by the department, a county enforcing agency, or a municipal enforcing agency may enter at all reasonable times in or upon any private or public property for the purpose of inspecting and investigating conditions or practices that may be in violation of this part.

History: Add. 1995, Act 60, Imd. Eff. May 24, 1995;--Am. 2000, Act 504, Imd. Eff. Jan. 11, 2001.

324.9114 Additional rules.

Sec. 9114. In order to carry out their functions under this part, the department and the department of agriculture may promulgate rules in addition to those otherwise authorized in this part.

History: Add. 1995, Act 60, Imd. Eff. May 24, 1995.

324.9115 Logging, mining, or land plowing or tilling; permit exemption; "mining" defined.

Sec. 9115. (1) Subject to subsection (2), a person engaged in the logging industry, the mining industry, or the plowing or tilling of land for the purpose of crop production or the harvesting of crops is not required to obtain a permit under this part. However, all earth changes associated with the activities listed in this section shall conform to the same standards as if they required a permit under this part. The exemption from obtaining a permit under this subsection does not include either of the following:

- (a) Access roads to and from the site where active mining or logging is taking place.
- (b) Ancillary activities associated with logging and mining.

(2) This part does not apply to a metallic mineral mining activity that is regulated under a mining and reclamation plan that contains soil erosion and sedimentation control provisions and that is approved by the department under part 631.

(3) A person is not required to obtain a permit from a county enforcing agency or a municipal enforcing agency for earth changes associated with well locations, surface facilities, flowlines, or access roads relating to oil or gas exploration and development activities regulated under part 615, if the application for a permit to drill and operate under part 615 contains a soil erosion and sedimentation control plan that is approved by the department under part 615. However, those earth changes shall conform to the same standards as required for a permit under this part. This subsection does not apply to a multisource commercial hazardous waste disposal well as defined in section 62506a.

(4) As used in this section, "mining" does not include the removal of clay, gravel, sand, peat, or topsoil.

History: Add. 1995, Act 60, Imd. Eff. May 24, 1995--Am. 2000, Act 504, Imd. Eff. Jan. 11, 2001.

324.9116 Reduction of soil erosion or sedimentation by owner.

Sec. 9116. A person who owns land on which an earth change has been made that may result in or contribute to soil erosion or sedimentation of the waters of the state shall implement and maintain soil erosion and sedimentation control measures that will effectively reduce soil erosion or sedimentation from the land on which the earth change has been made.

History: Add. 1995, Act 60, Imd. Eff. May 24, 1995.

324.9117 Notice of determination.

Sec. 9117. If the county enforcing agency or municipal enforcing agency that is responsible for enforcing this part and the rules promulgated under this part determines that soil erosion or sedimentation of adjacent properties or the waters of the state has or will reasonably occur from land in violation of this part or the rules promulgated under this part or an applicable local ordinance, the county enforcing agency or municipal enforcing agency may seek to enforce a violation of this part by notifying the person who owns the land, by mail, with return receipt requested, of its determination. The notice shall contain a description of the violation and what must be done to remedy the violation and shall specify a time to comply with this part and the rules promulgated under this part or an applicable local ordinance.

History: Add. 1995, Act 60, Imd. Eff. May 24, 1995;--Am. 2000, Act 504, Imd. Eff. Jan. 11, 2001.

324.9118 Compliance; time.

Sec. 9118. Within 5 days after a notice of violation has been issued under section 9117, a person who owns land subject to this part and the rules promulgated under this part shall implement and maintain soil erosion and sedimentation control measures in conformance with this part, the rules promulgated under this part, or an applicable local ordinance.

History: Add. 1995, Act 60, Imd. Eff. May 24, 1995;--Am. 2000, Act 504, Imd. Eff. Jan. 11, 2001.

324.9119 Entry upon land; construction, implementation, and maintenance of soil erosion and sedimentation control measures; cost.

Sec. 9119. Except as otherwise provided in this section, not sooner than 5 days after notice of violation of this part has been mailed under section 9117, if the condition of the land, in the opinion of the county enforcing agency or municipal enforcing agency, may result in or contribute to soil erosion or sedimentation of adjacent properties or to the waters of the state, and if soil erosion and sedimentation control measures in conformance with this part and the

rules promulgated under this part or an applicable local ordinance are not in place, the county enforcing agency or municipal enforcing agency, or a designee of either of these agencies, may enter upon the land and construct, implement, and maintain soil erosion and sedimentation control measures in conformance with this part and the rules promulgated under this part or an applicable local ordinance. However, the enforcing agency shall not expend more than \$10,000.00 for the cost of the work, materials, labor, and administration without prior written notice in the notice provided in section 9117 for the person who owns the land that the expenditure of more than \$10,000.00 may be made. If more than \$10,000.00 is to be expended under this section, then the work shall not begin until at least 10 days after the notice of violation has been mailed.

History: Add. 1995, Act 60, Imd. Eff. May 24, 1995--Am. 2000, Act 504, Imd. Eff. Jan. 11, 2001.

324.9120 Reimbursement of county or municipal enforcing agency; lien for expenses; priority; collection and treatment of lien.

Sec. 9120. (1) All expenses incurred by a county enforcing agency or a municipal enforcing agency under section 9119 to construct, implement, and maintain soil erosion and sedimentation control measures to bring land into conformance with this part and the rules promulgated under this part or an applicable local ordinance shall be reimbursed to the county enforcing agency or municipal enforcing agency by the person who owns the land.

(2) The county enforcing agency or municipal enforcing agency shall have a lien for the expenses incurred under section 9119 of bringing the land into conformance with this part and the rules promulgated under this part or an applicable local ordinance. However, with respect to single-family or multifamily residential property, the lien for such expenses shall have priority over all liens and encumbrances filed or recorded after the date of such expenditure. With respect to all other property, the lien for such expenses shall be collected and treated in the same manner as provided for property tax liens under the general property tax act, 1893 PA 206, MCL 211.1 to 211.157.

History: Add. 1995, Act 60, Imd. Eff. May 24, 1995--Am. 2000, Act 504, Imd. Eff. Jan. 11, 2001.

324.9121 Violations; penalties.

Sec. 9121. (1) A person who violates this part is responsible for either of the following:

(a) If the action is brought by a county enforcing agency or a municipal enforcing agency of a local unit of government that has enacted an ordinance under this part that provides a penalty for violations, the person is responsible for a municipal civil infraction and may be ordered to pay a civil fine of not more than \$2,500.00.

(b) If the action is brought by the state or a county enforcing agency of a county that has not enacted an ordinance under this part, the person is responsible for a state civil infraction and may be ordered to pay a civil fine of not more than \$2,500.00.

(2) A person who knowingly violates this part or knowingly makes a false statement in an application for a permit or in a soil erosion and sedimentation control plan is responsible for the payment of a civil fine of not more than \$10,000.00 for each day of violation.

(3) A person who knowingly violates this part after receiving a notice of determination under section 9112 or 9117 is responsible for the payment of a civil fine of not less than \$2,500.00 or more than \$25,000.00 for each day of violation.

- (4) Civil fines collected under subsections (2) and (3) shall be deposited as follows:
- (a) If the state filed the action under this section, in the general fund of the state.
 - (b) If a county enforcing agency or municipal enforcing agency filed the action under this section, with the county or municipality that filed the action.
 - (c) If an action was filed jointly by the state and a county enforcing agency or municipal enforcing agency, the civil fines collected under this subsection shall be divided in proportion to each agency's involvement as mutually agreed upon by the agencies. All fines going to the department shall be deposited into the general fund of the state.

(5) A default in the payment of a civil fine or costs ordered under this section or an installment of the fine or costs may be remedied by any means authorized under the revised judicature act of 1961, 1961 PA 236, MCL 600.101 to 600.9948.

(6) In addition to a fine assessed under this section, a person who violates this part is liable to the state for damages for injury to, destruction of, or loss of natural resources resulting from the violation. The court may order a person who violates this part to restore the area or areas affected by the violation to their condition as existing immediately prior to the violation.

(7) This section applies to an authorized public agency, in addition to other persons. This section does not apply to a county enforcing agency or a municipal enforcing agency with respect to its administration and enforcement of this part and rules promulgated under this part.

History: Add. 1995, Act 60, Imd. Eff. May 24, 1995;--Am. 1996, Act 173, Imd. Eff. Apr. 18, 1996;--Am. 2000, Act 504, Imd. Eff. Jan. 11, 2001.

324.9122 Severability.

Sec. 9122. If any provision of this part is declared by a court to be invalid, the invalid provision shall not affect the remaining provisions of the part that can be given effect without the invalid provision. The validity of the part as a whole or in part shall not be affected, other than the provision invalidated.

History: Add. 1995, Act 60, Imd. Eff. May 24, 1995.

324.9123 Training program; certificate; fees.

Sec. 9123. (1) Beginning 3 years after the effective date of the 2000 amendments to this section, each individual who is responsible for administering this part and the rules promulgated under this part or a local ordinance and who has decision-making authority for soil erosion and sedimentation control plan development or review, inspections, permit issuance, or enforcement shall be trained by the department. The department shall issue a certificate of training to individuals under this section if they do both of the following:

- (a) Complete a soil erosion and sedimentation control training program sponsored by the department.
- (b) Pass an examination on the subject matter covered in the training program under subdivision (a).

(2) A certificate of training under subsection (1) is valid for 5 years. For recertifications, the department may offer a refresher course or other update in lieu of the requirements of subsection (1)(a) and (b).

(3) The department may charge fees for administering the training program and the examination under this section that are not greater than the department's cost of administering the training program and the examination. All fees collected under this section shall be deposited into the soil erosion and sedimentation control training fund created in section 9123a.

History: Add. 1995, Act 60, Imd. Eff. May 24, 1995;--Am. 2000, Act 504, Imd. Eff. Jan. 11, 2001.

324.9123a Soil erosion and sedimentation control training fund; creation; disposition of funds; lapse; expenditures.

Sec. 9123a. (1) The soil erosion and sedimentation control training fund is created within the state treasury.

(2) The state treasurer may receive money or other assets from any source for deposit into the soil erosion and sedimentation control training fund. The state treasurer shall direct the investment of the soil erosion and sedimentation control training fund. The state treasurer shall credit to the soil erosion and sedimentation control training fund interest and earnings from fund investments.

(3) Money in the soil erosion and sedimentation control training fund at the close of the fiscal year shall remain in the fund and shall not lapse to the general fund.

(4) The department shall expend money from the fund, upon appropriation, only to administer the soil erosion and sedimentation control training program and examination under section 9123.

History: Add. 2000, Act 504, Imd. Eff. Jan. 11, 2001.

DEPARTMENT OF ENVIRONMENTAL QUALITY

WATER BUREAU

PART 17. SOIL EROSION AND SEDIMENTATION CONTROL

(By authority conferred on the department of environmental quality by sections 9104 and 9114 of 1994 PA 451, MCL 324.9104 and 324.9114)

Editor's Note: An obvious error in the authority line and was corrected at the request of the promulgating agency, pursuant to Section 56 of 1969 PA 306, as amended by 2000 PA 262, MCL 24.256. The authority line containing the error was published in Michigan Register, 2007 MR 19. The memorandum requesting the correction was published in Michigan Register, 2007 MR 20.

PART 17. SOIL EROSION AND SEDIMENTATION CONTROL

R 323.1701 Definitions.

Rule 1701. (1) As used in this part:

(a) "Accelerated soil erosion" means the increased loss of the land surface that occurs as a result of human activities.

(b) "Acceptable erosion and sediment control program" means the activities of a county or local enforcing agency or authorized public agency that are conducted in accordance with these rules and part 91 regarding staff training, developing and reviewing plans, issuing permits, conducting inspections, and initiating compliance and enforcement actions to effectively minimize erosion and off-site sedimentation.

(c) "Designated agent" means a person who has written authorization from the landowner to sign the application and secure a permit in the landowner's name.

(d) "Lake" means the Great Lakes and all natural and artificial inland lakes or impoundments that have definite banks, a bed, visible evidence of a continued occurrence of water, and a surface area of water that is equal to, or greater than, 1 acre. "Lake" does not include sediment basins and basins constructed for the sole purpose of storm water retention, cooling water, or treating polluted water.

(e) "Landowner" means the person who owns or holds a recorded easement on the property or who is engaged in construction in a public right-of-way in accordance with sections 13, 14, 15, and 16 of Act No. 368 of the Public Acts of 1925, as amended, being §§247.183, 247.184, 247.185, and 247.186 of the Michigan Compiled Laws.

(f) "Nonerosive velocity" means a speed of water movement that is not conducive to the development of accelerated soil erosion.

(g) "Part 91" means part 91 of Act No. 451 of the Public Acts of 1994, as amended, being §§324.9101 to 324.9123 of the Michigan Compiled Laws.

(h) "Sediment basin" means a naturally occurring or constructed depression used for the sole purpose of capturing sediment during or after an earth change activity.

(i) "Stabilization" means the establishment of vegetation or the proper placement, grading, or covering of soil to ensure its resistance to soil erosion, sliding, or other earth movement.

(j) "Storm water retention basin" means an area which is constructed to capture surface water runoff and which does not discharge directly to a lake or stream through an outlet. Water leaves the basin by infiltration and evaporation.

(k) "Stream" means a river, creek, or other surface watercourse which may

or may not be serving as a drain as defined in Act No. 40 of the Public Acts of 1956, as amended, being §280.1 et seq. of the Michigan Compiled Laws, and which has definite banks, a bed, and visible evidence of the continued flow or continued occurrence of water, including the connecting waters of the Great Lakes.

(1) "Temporary soil erosion and sedimentation control measures" means interim control measures which are installed or constructed to control soil erosion and sedimentation and which are not maintained after project completion.

(m) "Permanent soil erosion and sedimentation control measures" means control measures which are installed or constructed to control soil erosion and sedimentation and which are maintained after project completion.

(2) The terms defined in part 91 have the same meanings when used in these rules.

History: 1979 AC; 1998 AACS.

R 323.1702 Earth change requirements generally.

Rule 1702. (1) A person shall conduct an earth change in a manner that will effectively reduce accelerated soil erosion and resulting sedimentation.

(2) A person engaged in an earth change identified in R 323.1704 shall plan, implement, and maintain acceptable soil erosion and sedimentation control measures in conformance with part 91, which effectively reduce accelerated soil erosion and off-site sedimentation.

(3) A person shall set forth soil erosion and sedimentation control measures in a plan as prescribed by R 323.1703. A person shall make the plan available for inspection at all times at the site of the earth change. The department, or its designated representative, may require the county or local enforcing agency to file a copy of the plan with the department.

(4) A person shall obtain a permit containing state prescribed information, as required by R 323.1707, and make the permit available for inspection at the site of the earth change.

History: 1979 AC; 1998 AACS.

R 323.1703 Soil erosion and sedimentation control plan requirements.

Rule 1703. A person shall prepare a soil erosion and sedimentation control plan for any earth change identified in R 323.1704. A person shall design the plan to effectively reduce accelerated soil erosion and sedimentation and shall identify factors that may contribute to soil erosion or sedimentation, or both. The plan shall include, but not be limited to, all of the following:

(a) A map or maps at a scale of not more than 200 feet to the inch or as otherwise determined by the county or local enforcing agency. A map shall include a legal description and site location sketch that includes the proximity of any proposed earth change to lakes or streams, or both; predominant land features; and contour intervals or slope description.

(b) A soils survey or a written description of the soil types of the exposed land area contemplated for the earth change.

(c) Details for proposed earth changes, including all of the following:

(i) A description and the location of the physical limits of each proposed earth change.

(ii) A description and the location of all existing and proposed on-site drainage and dewatering facilities.

(iii) The timing and sequence of each proposed earth change.

(iv) The location and description for installing and removing all proposed temporary soil erosion and sediment control measures.

(v) A description and the location of all proposed permanent soil erosion

and sediment control measures.

(vi) A program proposal for the continued maintenance of all permanent soil erosion and sediment control measures that remain after project completion, including the designation of the person responsible for the maintenance. Maintenance responsibilities shall become a part of any sales or exchange agreement for the land on which the permanent soil erosion control measures are located.

History: 1979 AC; 1998 AACS.

R 323.1704 Permit requirements.

Rule 1704. (1) A landowner or designated agent who contracts for, allows, or engages in, an earth change in this state shall obtain a permit from the appropriate enforcing agency before commencing an earth change which disturbs 1 or more acres of land or which is within 500 feet of the water's edge of a lake or stream, unless exempted in R 323.1705.

(2) An earth change activity that does not require a permit under subrule (1) of this rule is not exempt from enforcement procedures under part 91 or these rules, if the activity exempted by subrule (1) of this rule causes or results in a violation of part 91 or these rules.

History: 1979 AC; 1998 AACS.

R 323.1705 Permit exemptions and waivers.

Rule 1705. (1) A permit is not required for any of the following:

(a) A beach nourishment project permitted under part 325 of Act No. 451 of the Public Acts of 1994, as amended, being § 324.32501 et seq. of the Michigan Compiled Laws.

(b) Normal road and driveway maintenance, such as grading or leveling, that does not increase the width or length of the road or driveway and that will not contribute sediment to lakes or streams.

(c) An earth change of a minor nature that is stabilized within 24 hours of the initial earth disturbance and that will not contribute sediment to lakes or streams

(d) Installation of oil, gas, and mineral wells under permit from the supervisor of wells if the owner-operator is found by the supervisor of wells to be in compliance with the conditions of part 91.

(2) A county or local enforcing agency may grant a permit waiver for an earth change after receiving a signed affidavit from the landowner stating that the earth change will disturb less than 225 square feet and that the earth change will not contribute sediment to lakes or streams.

(3) Exemptions provided in subrules (1) and (2) of this rule shall not be construed as exemptions from enforcement procedures under part 91 or these rules, if the activities exempted by subrules (1) and (2) cause or result in a violation of part 91 or these rules.

History: 1979 AC; 1998 AACS.

R 323.1706 Application for permit.

Rule 1706. (1) A landowner or designated agent shall submit an application for a permit to the appropriate enforcing agency.

(2) A landowner or designated agent shall submit, with the application, a soil erosion and sedimentation control plan and any other document that the appropriate enforcing agency may require.

(3) The county or local enforcing agency shall provide an application requiring state prescribed information to an applicant.

(4) An authorized public agency is exempt from obtaining a permit from a

county or local enforcing agency, but shall notify the county or local enforcing agency of each proposed earth change.

History: 1979 AC; 1998 AACS.

R 323.1707 Application review and permit procedures.

Rule 1707. (1) A person who is designated by the county or local enforcing agency who is trained in soil erosion and sedimentation control methods and techniques shall review and approve a soil erosion and sedimentation control plan.

(2) The appropriate enforcing agency shall approve, disapprove, or require modification of an application for an earth change permit within 30 calendar days following receipt of the application. The enforcing agency shall notify an applicant of by first-class mail. If an applicant is disapproved, then the enforcing agency shall advise the applicant by certified mail of its reasons for disapproval and conditions required for approval. The enforcing agency need not notify an applicant of approval or disapproval by mail if the applicant is given written approval or disapproval of the application in person. A permit given to the applicant either in person or by first-class mail constitutes approval.

(3) A permit that contains state prescribed information shall be used by each county or local enforcing agency and shall include any additional provisions required by the county or local enforcing agency. The permit shall be available at the site of the earth change for inspection.

(4) Upon a determination that a permit applicant has met all of the requirements of these rules, Part 91 and the local ordinance, if applicable, the appropriate enforcing agency shall issue a permit for the proposed earth change.

History: 1979 AC; 1998 AACS; 2007 AACS.

R 323.1708 Soil erosion and sedimentation control procedures and measures generally.

Rule 1708. A person who applies for an earth change permit shall incorporate the soil erosion and sedimentation control procedures and measures prescribed by R 323.1709 and R 323.1710 into the soil erosion and sedimentation control plan and shall apply the procedures and measures to all earth changes identified in the plan, unless the person preparing the plan shows, to the satisfaction of the appropriate enforcing agency, that altering the control procedures or measures or including other control procedures or measures will prevent accelerated soil erosion and sedimentation during the earth change.

History: 1979 AC; 1998 AACS.

R 323.1709 Earth change requirements: time; sediment removal; design, installation, and removal of temporary or permanent control measures.

Rule 1709. (1) A person shall design, construct, and complete an earth change in a manner that limits the exposed area of any disturbed land for the shortest possible period of time as determined by the county or local enforcing agency.

(2) A person shall remove sediment caused by accelerated soil erosion from runoff water before it leaves the site of the earth change.

(3) A person shall design a temporary or permanent control measure that is designed and constructed for the conveyance of water around, through, or from the earth change area to limit the water flow to a nonerosive velocity.

(4) A person shall install temporary soil erosion and sedimentation

control measures before or upon commencement of the earth change activity and shall maintain the measures on a daily basis. A person shall remove temporary soil erosion and sedimentation control measures after permanent soil erosion measures are in place and the area is stabilized. A person shall stabilize the area with permanent soil erosion control measures under approved standards and specifications as prescribed by R 323.1710.

(5) A person shall complete permanent soil erosion control measures for all slopes, channels, ditches, or any disturbed land area within 5 calendar days after final grading or the final earth change has been completed. If it is not possible to permanently stabilize a disturbed area after an earth change has been completed or if significant earth change activity ceases, then a person shall maintain temporary soil erosion and sedimentation control measures until permanent soil erosion control measures are in place and the area is stabilized.

History: 1979 AC; 1998 AACS.

R 323.1710 Standards and specifications.

Rule 1710. A person shall complete all temporary and permanent erosion and sedimentation control measures according to the approved plan or operating procedures.

(1) A person shall install and maintain control measures in accordance with the standards and specifications of all of the following:

- (a) The product manufacturer.
- (b) The local conservation district.
- (c) The department.
- (d) The Michigan department of transportation.
- (e) The enforcing agency, if applicable and formally adopted.

(2) If a conflict exists between the standards and specifications, then the enforcing agency or authorized public agency shall determine which specifications are appropriate for the project.

History: 1979 AC; 1998 AACS.

R 323.1711 Building permits.

Rule 1711. (1) A local agency or general law township that issues building permits shall notify the county or local enforcing agency immediately upon receipt of an application for a building permit that requires an earth change which disturbs 1 or more acres or which is located within 500 feet of a lake or stream.

(2) A local agency or general law township shall not issue a building permit to a person engaged in an earth change if the change requires a permit under part 91 or these rules until the county or local enforcing agency has issued the required state-prescribed permit for the earth change.

History: 1979 AC; 1998 AACS.

R 323.1712 Enforcement.

Rule 1712. The county or local enforcing agency may issue a cease and desist order or revoke a permit upon its finding that there is a violation of part 91, these rules, or an approved local ordinance or a finding that there is a violation of a permit or an approved soil erosion and sedimentation control plan.

History: 1979 AC; 1998 AACS.

R 323.1713 Periodic review.

Rule 1713. The department shall conduct an ongoing comprehensive review and evaluation of all soil erosion and sedimentation control programs that operate under part 91 and these rules. The department shall notify county and local enforcing agencies and authorized public agencies as to the acceptability of their soil erosion and sedimentation control programs. The department shall make available a report of its findings of the review and evaluation of all enforcing agencies and authorized public agencies.

History: 1979 AC; 1998 AACS.

R 323.1714 Availability of documents.

Rule 1714. Copies of the local conservation district standards and specifications for soil erosion and sedimentation control, as referred to in R 323.1710, are available at each local conservation district office at a nominal cost. Copies of the department's standards are available from the surface water quality division's Lansing office. Department of transportation standards are available at the Lansing office for a fee. Information on other standards may be available from product manufacturers and the enforcing agencies.

History: 1979 AC; 1998 AACS.

Appendix 3

MICHIGAN DEPARTMENT OF MANAGEMENT AND BUDGET

S-E-S-C KEYING SYSTEM



KEY	BEST MANAGEMENT PRACTICES	SYMBOL	WHERE USED
EROSION CONTROLS			
E1	SELECTIVE GRADING AND SHAPING		To reduce steep slopes and erosive velocities.
E2	GRUBBING OMITTED		For use on steep slopes to prevent rilling, gulying, and reduce sheet flow velocity or where clear vision corridors are necessary.
E3	SLOPE ROUGHENING AND SCARIFICATION		Where created grades cause increased erosive velocities. Promotes infiltration and reduces runoff velocity.
E4	TERRACES		On relatively long slopes up to 8% grades with fairly stable soils.
E5	DUST CONTROL		For use on construction sites, unpaved roads, etc. to reduce dust and sedimentation from wind and construction activities.
E6	MULCH		For use in areas subject to erosive surface flows or severe wind or on newly seeded areas.
E7	TEMPORARY SEEDING		Stabilization method utilized on construction sites where earth change has been initiated but not completed within a 2 week period.
E8	PERMANENT SEEDING		Stabilization method utilized on sites where earth change has been completed (final grading attained).
E9	MULCH BLANKETS		On exposed slopes, newly seeded areas, new ditch bottoms, or areas subject to erosion.
E10	SODDING		On areas and slopes where immediate stabilization is required.
E11	VEGETATED CHANNELS		For use in created stormwater channels. Vegetation is used to slow water velocity and reduce erosion within the channel.
E12	RIPRAP		Use along shorelines, waterways, or where concentrated flows occur. Slows velocity, reduces sediment load, and reduces erosion.
E13	GABION WALLS		On newly created or denuded stream banks to reduce velocity until permanent stabilization is achieved or on existing banks to retard erosive velocities.
E14	ENERGY DISSIPATOR		Where the energy transmitted from a concentrated flow of surface runoff is sufficient to erode receiving area or watercourse.
E15	TEMPORARY SLOPE DRAIN		Where surface runoff temporarily accumulates or sheet flows over the top of a slope and must be conveyed down a slope in order to prevent erosion.
E16	SLOPE DRAIN		Where concentrated flow of surface runoff must be permanently conveyed down a slope in order to prevent erosion.

B = BIOENGINEERING

MICHIGAN DEPARTMENT OF MANAGEMENT AND BUDGET

S-E-S-C KEYING SYSTEM



KEY	BEST MANAGEMENT PRACTICES	SYMBOL	WHERE USED
E17	CELLULAR CONFINEMENT SYSTEMS		Used on steep slopes and high velocity channels.
E18	PLASTIC SHEETS		Used on exposed slopes, seeded areas, new ditch bottoms, and areas subject to surface runoff and erosion. Used as a liner in temporary channels and to stabilize stockpiles.
E19	TEMPORARY DRAINAGEWAY/ STREAM CROSSING		Use on construction sites where stream/drainageway crossings are required.
E20	TEMPORARY BYPASS CHANNEL		Use within existing stream corridors when existing flow cannot be interrupted, and at culvert and bridge repair sites
E21	LIVE STAKING		In areas requiring protection of slopes against surface erosion and shallow mass wasting.
EROSION / SEDIMENT CONTROLS			
ES31	CHECK DAM		Used to reduce surface flow velocities within constructed and existing flow corridors.
ES32	STONE FILTER BERM		Use primarily in areas where sheet or rill flow occurs and to accommodate dewatering flow.
ES33	FILTER ROLLS		In areas requiring immediate protection of slopes against surface erosion and gully formation and for perimeter sediment control.
ES34	SAND FENCE		For use in areas susceptible to wind erosion, especially where the ground has not yet been stabilized by other means.
ES35	DEWATERING		Use where construction activities are limited by the presence of water and dry work is required.
ES36	DIVERSION DIKE/BERM		Within existing flow corridors to address or prevent erosion and sedimentation, or on disturbed or unstable slopes subject to erosive surface water velocities.
ES37	DIVERSION DITCH		In conjunction with a diversion dike, or where diversion of upslope runoff is necessary to prevent damage to unstabilized or disturbed construction areas.
ES38	COFFERDAM/SHEET PILING		Constructed along or within water corridor or waterbody to provide dry construction area.
ES39	STREAMBANK BIOSTABILIZATION		For use along banks where stream and riparian zones may have difficulty recovering from the long-term effects of erosion.
ES40	POLYMERS		To minimize soil erosion and reduce sedimentation in water bodies by increasing soil particle size.
ES41	WATTLES		In areas requiring protection of slopes against surface erosion and gully formation.

B = BIOENGINEERING

MICHIGAN DEPARTMENT OF MANAGEMENT AND BUDGET

S-E-S-C KEYING SYSTEM



KEY	BEST MANAGEMENT PRACTICES	SYMBOL	WHERE USED
SEDIMENT CONTROLS			
S51	SILT FENCE		Use adjacent to critical areas, to prevent sediment laden sheet flow from entering these areas.
S52	CATCH BASIN SEDIMENT GUARD		Use in or at stormwater inlets, especially at construction sites.
S53	STABILIZED CONSTRUCTION ACCESS		Used at every point where construction traffic enters or leaves a construction site.
S54	TIRE WASH		For use on construction sites where vehicular traffic requires sediment removed from its tires in highly erosive areas.
S55	SEDIMENT BASIN		At the outlet of disturbed areas and at the location of a permanent detention basin.
S56	SEDIMENT TRAP		In small drainage areas, along construction site perimeters, and above check dams or drain inlets.
S57	VEGETATED BUFFER/FILTER STRIP		Use along shorelines, waterways, or other sensitive areas. Slows velocity, reduces sediment load, and reduces erosion in areas of sheet flow.
S58	INLET PROTECTION FABRIC DROP		Use at stormwater inlets, especially at construction sites.
S59	INLET PROTECTION FABRIC FENCE		Use at stormwater inlets, especially at construction sites.
S60	INLET PROTECTION STONE		Use around urban stormwater inlets.
S61	TURBIDITY CURTAIN		Use during construction adjacent to a water esource, to contain sediment within the work area when other BMP's cannot be used.

B = BIOENGINEERING

Appendix 4

E1

SELECTIVE GRADING AND SHAPING

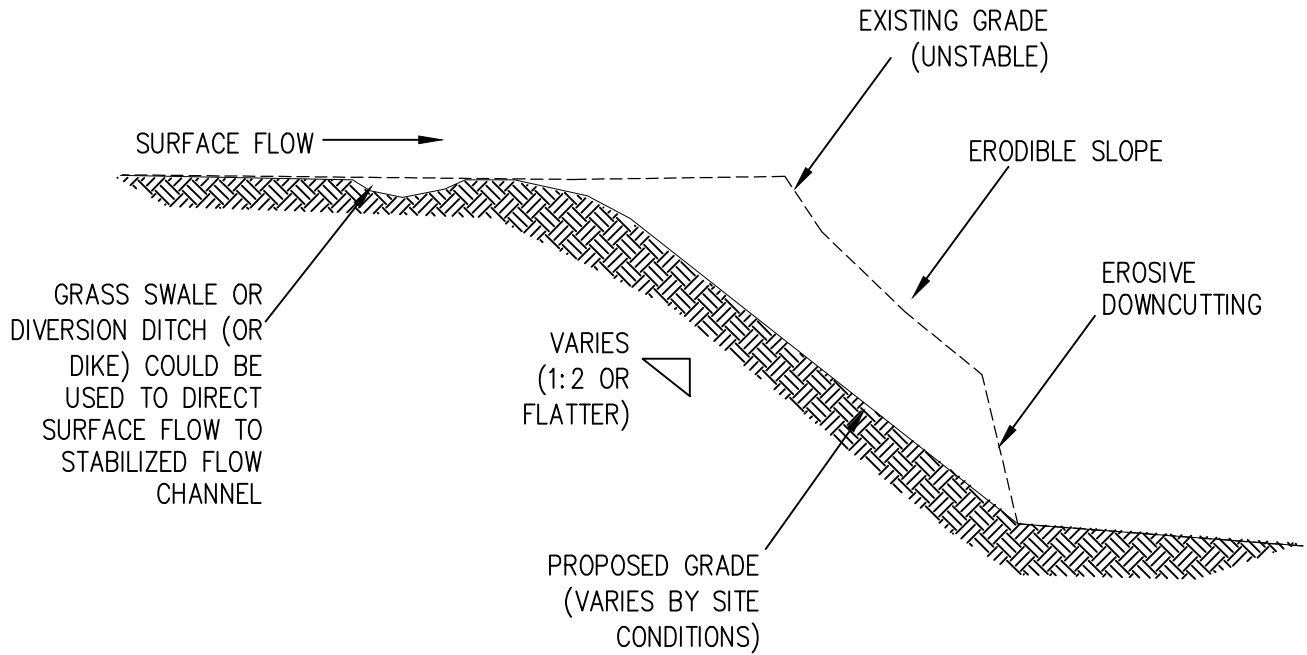

- NOTE: PROPOSED GRADE DEPENDENT ON SITE SPECIFIC CHARACTERISTICS SUCH AS SOIL TYPE, VEGETATIVE COVER, AND WATER MOVEMENT ABOVE AND BELOW GRADE.

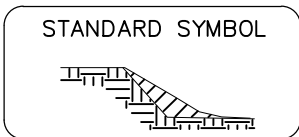

SELECTIVE GRADING AND SHAPING SPECIFICATIONS



- When
- Whenever existing slopes or construction activities result in grades which may be subject to erosive flow velocities capable of downcutting or erosion resulting in off-site sedimentation.
- Why
- To inhibit slope failure and soil erosion.
- Where
- Where existing natural or created grades are subject to surface flows capable of creating gullies, rills, or other surface erosion problems.
- How
1. Review existing conditions on site.
 2. Identify existing surface flow paths/existing and potential erosion problems.
 3. Develop a grading plan considering flow paths and rates, soil permeability, and vegetative cover.
 4. Phase selective grading to minimize area of disturbance on the construction site.
 5. Establish slopes appropriate for intended use. Slopes, in general, should be flatter than 1:2. Slopes requiring mowing should be no steeper than 1:3.
 6. Avoid sensitive areas (watercourses, wetlands, vegetative buffers) with grading/shaping.
 7. Divert surface flows to areas appropriately stabilized to handle expected volumes and velocities.
 8. Locate spoil areas away from sensitive areas or flow paths and stabilize with seed.
 9. Exposed areas should be stabilized with vegetation or other ground cover as soon as work is completed or interrupted for 2 normal work weeks.
- Maintenance
- Surface flows should be diverted off graded slopes until vegetation is completely established.





SELECTIVE GRADING AND SHAPING SPECIFICATIONS

Maintenance
(cont.)

- Slopes steeper than 1:3 should be stabilized with mulch blankets to aid in soil retention and seed germination.
- Created slopes should be inspected at least monthly during first year of establishment to identify and address soil erosion problems as they occur.

Limitations

- Effectiveness of grading determined by soil type, vegetative cover, and water movement.
- Long term effectiveness dependent upon successful establishment of vegetative cover and avoidance of concentrated surface flows.



**GRAND VALLEY
STATE UNIVERSITY.**

E2

GRUBBING OMITTED

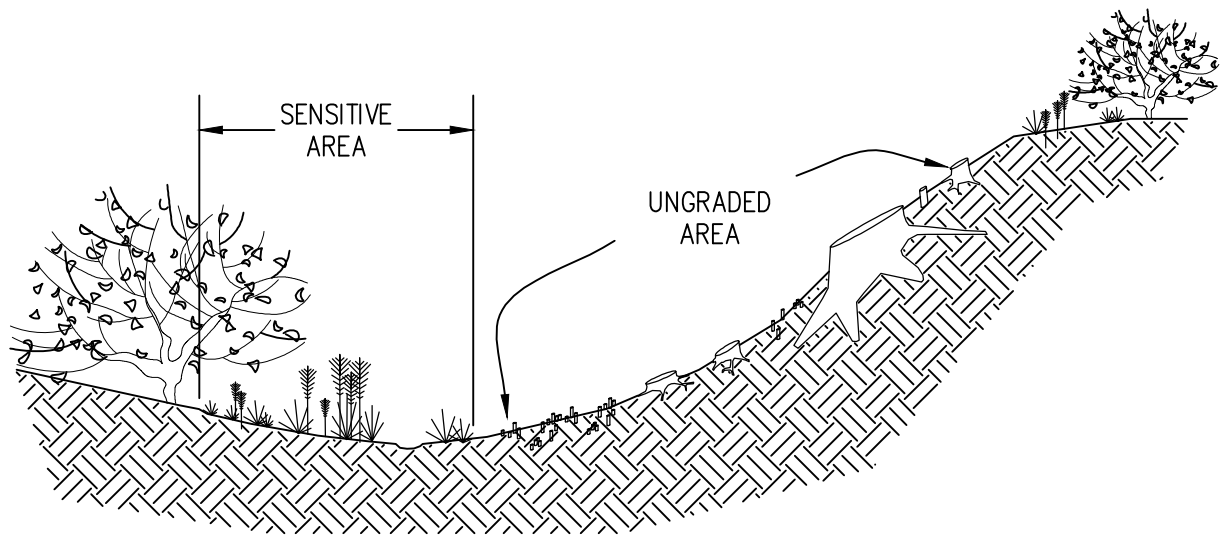

STANDARD SYMBOL



**GRAND VALLEY
STATE UNIVERSITY.**

GRUBBING OMITTED SPECIFICATIONS

E2

- When
- When retaining vegetative root masses can allow visual access or aid in slope stabilization.
- Why
- To prevent rilling and gullyng and hold soil in place on sites where construction requires vegetative removal.
 - To create clear vision areas or sightlines while maintaining slope stability.
- Where
- For use on slopes where bridge spans and boardwalk construction is proposed or where clear vision corridors are necessary.
- How
1. Identify areas where grubbing is not necessary.
 2. Cut vegetation within a few inches of natural ground surface.
 3. Leave root zone intact. Do not grade area.
- Maintenance
- To maintain visual corridors, woody vegetation must be cut on an annual or biannual basis.
 - Keep vehicular traffic out of area.
- Limitations
- Stumps and other woody remnants inhibit mowing.
 - Requires annual maintenance to maintain reduced vegetation height.



**GRAND VALLEY
STATE UNIVERSITY.**

E3

SLOPE ROUGHENING AND SCARIFICATION

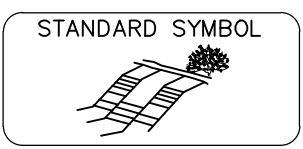
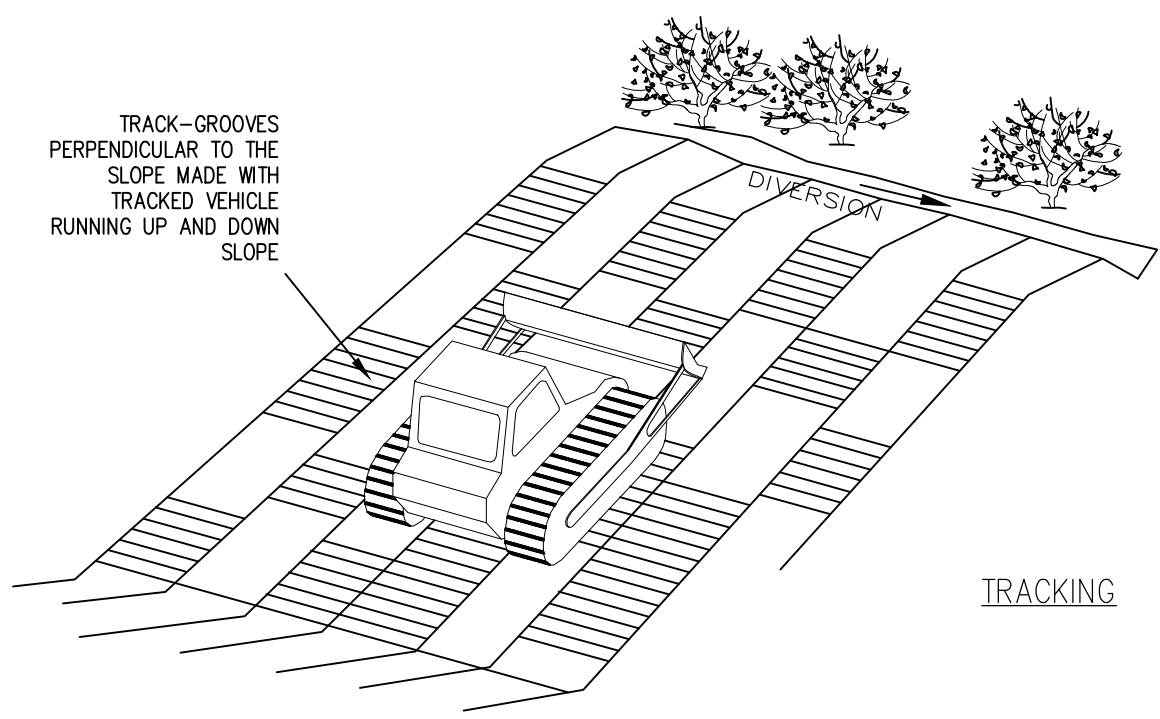
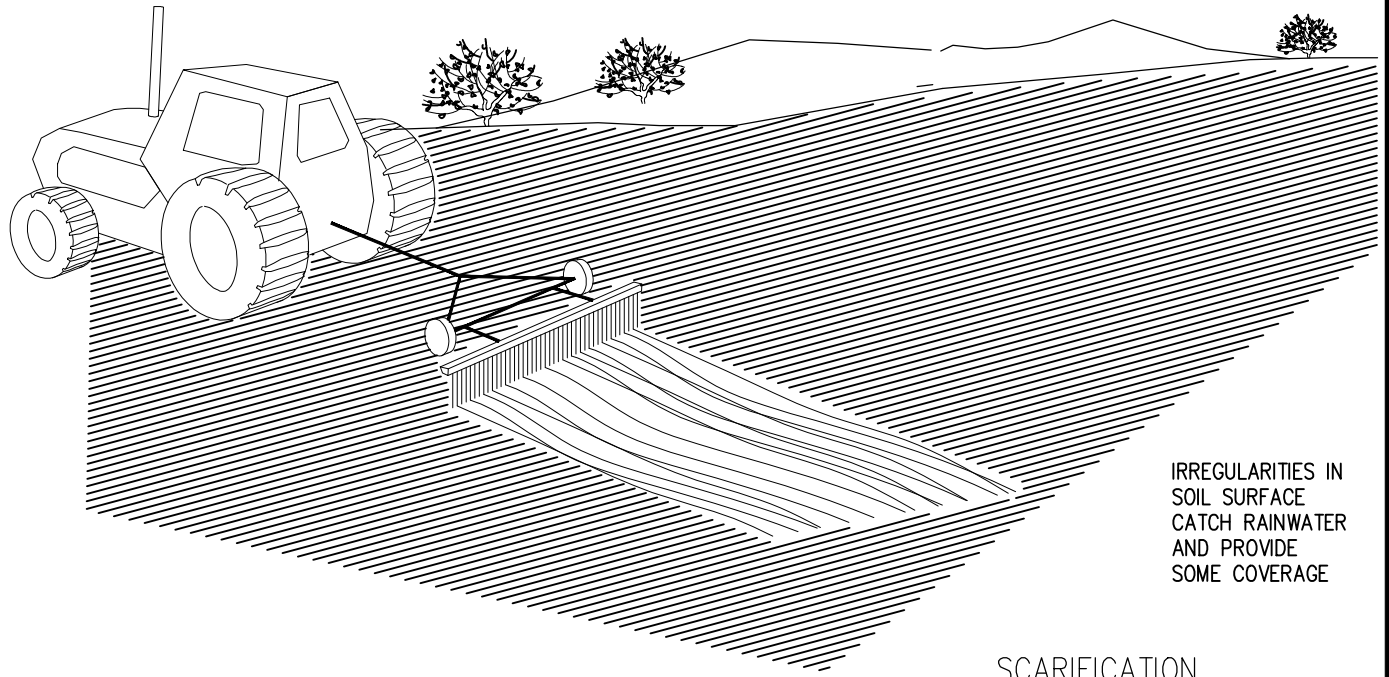

SLOPE ROUGHENING AND SCARIFICATION SPECIFICATIONS



- When
- When site grading or construction activities result in grades that may cause increased erosive velocities or off-site sedimentation.
 - To promote infiltration and reduce runoff velocity.
- Why
- To reduce runoff velocity, increase infiltration, aid in the establishment of vegetation, and reduce erosion.
- Where
- Used on slopes as a temporary erosion control or to assist in the establishment of vegetation.
- How
1. Conduct grading activities removing vegetative matter.
 2. As soon as final grade is completed, slope roughening or scarification should be completed to reduce surface water velocities, promote vegetative establishment, reduce erosion, and promote infiltration.
 3. Slope roughening techniques:
 - Tracking – Roughening slopes by running tracked machinery up and down slopes to create horizontal depressions perpendicular to slope direction.
 - Temporary measure only.
 - Creates seeding "safe sites".
 - Back-blading –Blade drawn across soil parallel to contour.
 - Scarification –Running scarifier perpendicular to slope to roughen surface.
 4. Following soil roughening, stabilize areas with vegetation, structures, or surface material as appropriate.
- Maintenance
- Review slopes and maintain slope stability until vegetation is established or the final surface treatment is applied.
 - Stabilize work area as soon as final grade is reached.
 - The diversion should be removed after slope is stabilized.





SLOPE ROUGHENING AND SCARIFICATION SPECIFICATIONS

- Limitations
- Roughening has limited effectiveness on its own, but is used to speed revegetation.
 - Steep slopes limit ability to safely use vehicles to roughen soil.



**GRAND VALLEY
STATE UNIVERSITY.**

E4

TERRACES

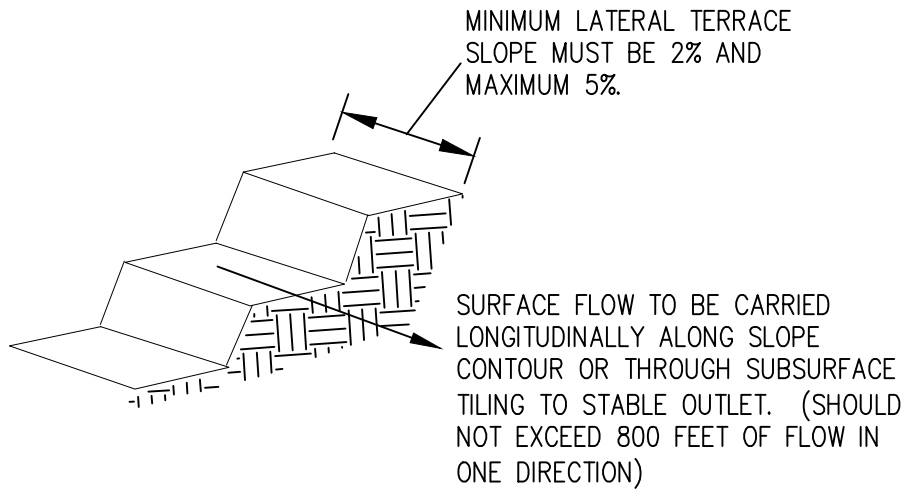
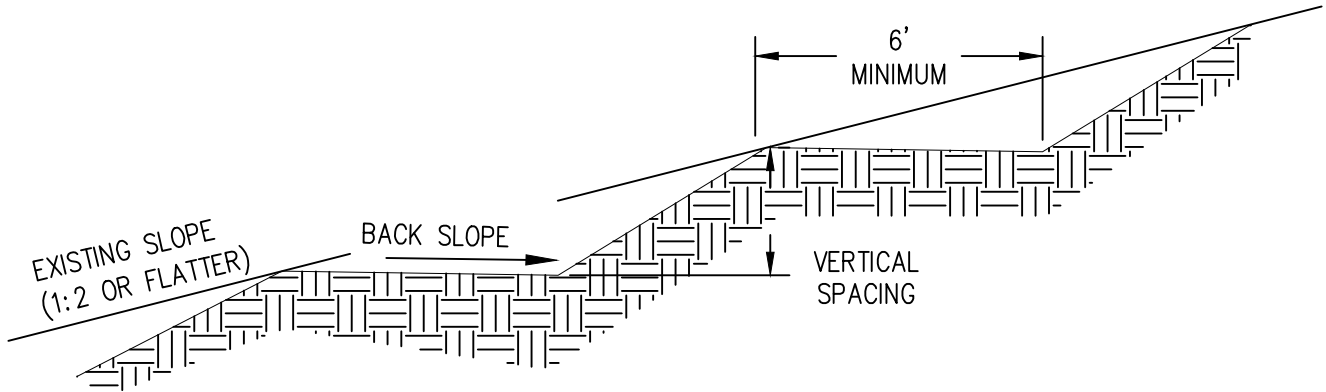

TYPICAL TERRACE DETAIL

TERRACE SPACING

EXISTING SLOPE (V:H)	MAXIMUM VERTICAL SPACING BETWEEN TERRACES (FT.)
1:2	20
1:3	30
1:4	40

STANDARD SYMBOL



**GRAND VALLEY
STATE UNIVERSITY.**

TERRACES SPECIFICATIONS

- When
- When surface water runoff onto steep slopes has the potential to cause sedimentation.
- Why
- To reduce runoff velocities, minimize sedimentation, increase infiltration, to provide access to steeper slopes for construction or maintenance purposes, and to allow for vegetation establishment.
- Where
- On relatively long slopes with fairly stable soils.
- How
1. Terraces should be designed by a professional engineer or landscape architect and included in original project plans.
 2. Factors to be considered include slope steepness, expected runoff velocities, existing soil type, slope formation (cut vs. fill), slope length, and mowing or equipment access requirements.
 3. Review site and site plan to identify long slopes steeper than 1:3.
 4. Locate terraces along contours perpendicular to slope direction.
 5. Terraces can be constructed with a slight cross-slope grade to divert surface runoff to stabilized outlet locations. Underground tiling on terraces can facilitate control of runoff.
 6. Slight back sloping of terrace into existing slope will promote infiltration/reduce surface water runoff.
 7. Terraces can be established by cutting furrows or carving shelves along parallel slope contours.
 8. Stabilize terraces by vegetative planting immediately following construction.
 9. Surface flows need to be diverted from terraces until vegetation is established.
- Maintenance
- Terraces should be inspected on a weekly basis and following each rain event.
 - Surface failures, such as gully formation or slumping, should be repaired immediately after inspection.



TERRACES SPECIFICATIONS

Maintenance (cont.)

- Terrace runoff outlet points should be regularly inspected to ensure positive drainage outlet is maintained.
- Vegetative integrity of terraces should be monitored/maintained.

Limitations

- May require extensive earthmoving to obtain appropriate cross section.
- Cuts may expose unsuitable soil. May be remedied by stockpiling topsoil and redistributing after rough grading is completed.
- Stabilizing terrace slopes may be difficult.



**GRAND VALLEY
STATE UNIVERSITY.**

E5

DUST CONTROL SPECIFICATIONS

- When
- On construction sites during periods of low precipitation, low humidity, and high temperature or high winds.
- Why
- To reduce dust and sedimentation from wind and construction activities.
- Where
- Use on unpaved roadways, construction sites with vehicle traffic, soil stockpile areas, and general areas with unstabilized, or fine soils.
- How
1. Dust control applications can include watering, chemical dust suppression, gravel or asphalt surfacing, temporary aggregate cover, and haul truck covers.
 2. Minimize length of time vulnerable areas are exposed on construction site.
 3. Identify and stabilize key access points prior to initiating construction.
 4. Quickly stabilize exposed soil by vegetation, mulch, soil erosion control blankets, spray-on adhesives, sprinkling, or stone layering to minimize areas in need of dust control.
 5. Follow manufacturers instructions regarding application of any dust palliative. Pay particular attention to mixing details.
 6. Apply dust suppressant to surfaces using a pressure type water distributor truck equipped with a spray system.
 7. The number of applications to be determined by site engineer.
 8. Immediately clean-up sediment tracked onto paved roads.
 9. Limit vehicle traffic to 15 miles per hour.
 10. Utilize aggregate cover on access, parking, and paved roads.
 11. Keep construction traffic directed to stabilized site roadways when possible.

STANDARD SYMBOL



**GRAND VALLEY
STATE UNIVERSITY.**

DUST CONTROL SPECIFICATIONS

E5

- Maintenance
- Frequent, even daily application may be required to increase effectiveness.
 - Do not overwater, as overwatering may cause erosion.
 - Oil should not be used for dust control, as it may enter a drainageway through runoff or seeping into the soil.
- Limitations
- To continue its effectiveness, dust control application needs to be applied on a regular schedule.
 - Applying too much water to surface may cause erosion.
 - Some types of dust suppressants may make soil water repellent, increasing runoff.



**GRAND VALLEY
STATE UNIVERSITY.**



MULCHING SPECIFICATIONS

- When
- When areas are subject to erosive surface sheet flows or severe wind.
- Why
- Temporarily protects seeded areas and slopes against erosion from rain or wind. Holds soil moisture to allow for seed germination and reduces wind desiccation of germinated seeds. Inhibits seed consumption by birds.
- Where
- Use on exposed slopes, newly seeded areas and other areas subject to erosion.
- How
1. Other surface runoff control measures should be installed prior to mulching.
 2. Prepare surface to proper grade and compaction requirements.
 3. If treatment area is to be revegetated immediately, spread or drill seed, or install vegetative sprigs into planting surface.
 4. Select mulch material appropriate for site characteristics, including grade, level of traffic, installation method, and accessibility.
Straw – Most common and widely used material. Provides organic matter as it breaks down. Effectiveness of sediment reduction high for at least 3 months. Subject to windblow and washout. For straw, apply a minimum of 2 tons/acre or approx. 50 lbs./1000 sq.ft. to cover the surface. Increase application rates 50% for dormant seeding.
Rock – Crushed stone and gravel maintain effectiveness indefinitely if maintained to repair compaction. Cover 2–3” in depth (approx. 2.27 tons/1000 sq. ft.).
Wood chips/bark – Chips decompose slowly but may require nitrogen fertilizer application to avoid nutrient deficiency. Tend to wash down slopes over 6% and may clog inlet grates. Cover 2–3” in depth.
 5. Mulches should not be applied if free surface water is present but may be applied to wet soil.

STANDARD SYMBOL



MULCHING SPECIFICATIONS

How
(cont.)

6. Mulches (particularly straw) may need anchoring. Common methods include crimping, disking, or punching into soil; covering with netting; spraying with a binder/tackifier, or keeping moist.
7. If using a tackifier to anchor mulch in place, apply immediately after mulch has been placed. Tackifiers include:

Latex–Base. Mix 37 gallons of adhesive or the manufacturer’s recommended rate with a minimum of 620 lbs. of recycled newsprint as a tracer with 925 gallons of water.

Recycled Newsprint. Mix 1850 lbs. of newsprint with 3700 gallons of water.

Wood Fiber. Mix 1850 lbs. of wood fiber with 3700 gallons of water.

Guar Gum. Mix 120 lbs. of dry adhesive and a minimum of 620 lbs. recycled newsprint as a tracer with 3225 gallons of water.

Other Tackifiers. Mix 240 lbs. of dry adhesive or the manufacturer’s recommended rate and a minimum of 620 lbs. of recycled newsprint as a tracer with 3225 gallons of water.

- Maintenance
- Inspect mulched areas periodically and after any storm event. Repair damaged areas, reseed or replace vegetation (if necessary), and replace lost mulch immediately.
 - Keep eroded soil, vehicular and pedestrian traffic, and concentrated runoff away from the mulched area.

- Limitations
- Mulch can be blown or washed away if not secured.
 - Organic mulches, particularly thick applications of wood chips, can reduce nitrogen availability to desired plants, may inhibit good surface coverage by vegetation, and should be supplemented with fertilizer.
 - Tackifiers are slippery when wet. Equipment must be kept clean to prevent accidents.
 - Tackifiers can mark vehicles, signs, or other objects if these items are not protected.
 - Hay mulch should not be used, as it can contain noxious weeds.



TEMPORARY SEEDING SPECIFICATIONS

- When
- When an area needs stabilization during a break in construction.
- Why
- Stabilizes soil.
 - Prevents erosion/sedimentation problems from developing.
 - Allows runoff to infiltrate soil.
- Where
- Used on construction and earth change sites where earth change has been initiated but will not be completed within two normal work weeks.
 - A temporary measure when an area needs stabilization during a break in construction.
- How
1. Review construction phasing and soil erosion control plan to identify areas requiring temporary seeding.
 2. Select annual grass seed for temporary cover areas.
 3. Seed mixes may vary, should only contain annual, non-aggressive species, and generally include rye, wheat, or oat species. Seed mixes should be obtained from a seed supplier as seed mixes are dependent on soil type, light, moisture, and use application.
 4. Prepare seedbed by removal of construction/woody debris. Then scarify or rake seedbed.
 5. Slopes steeper than 1:3 should be roughened.
 6. Apply seed as soon as possible after seedbed preparation. Mulch immediately after seeding all slopes, unstable soils, heavy clay soils, and all areas adjacent to wetlands, watercourses, or sensitive areas.
 7. The time to seed is dependent on the climate of the area. Michigan has three climatic zones.
 8. Protect seeded areas from pedestrian/vehicular traffic.
 9. Divert concentrated flows away from seeded area until vegetation is established.

STANDARD SYMBOL



**GRAND VALLEY
STATE UNIVERSITY.**

TEMPORARY SEEDING DATES

- How (cont.)
- 10. Inspect temporary seeded areas weekly and following each rain event until final grading and stabilization activities are completed.
 - 11. Must be followed by permanent seeding.

- Limitations
- Seeds need adequate time to establish.
 - May not be appropriate in areas with frequent traffic.
 - Seeded area may require irrigation in dry periods.

<u>Seed Type</u>	<u>Zone 1</u>	<u>Zone 2</u>	<u>Zone 3</u>	<u>Amount</u>	
	Lower Peninsula (South of U.S. 10)	Lower Peninsula (North of U.S. 10)	Upper Peninsula	per 1,000 sq.ft.	per acre
Oats, barley	4/1 – 9/15	4/15 – 8/1	5/1 – 8/1	2 lbs.	96 lbs.
Annual Rye	8/1 – 10/15	8/1 – 10/10	8/1 – 11/1	3 lbs.	120 lbs.
Wheat	9/20 – 10/15	9/10 – 10/10	9/10 – 10/1	3 lbs.	120 lbs.
Buckwheat	6/1 – 7/15	6/1 – 7/15	6/15 – 7/15	2 lbs.	75 lbs.
Perennial Ryegrass	8/1 – 10/15	6/1 – 8/1	8/1 – 10/1	0.5 lbs.	20 lbs.

Source: Adapted from USDA NRCS Technical Guide #342 (1999)





PERMANENT SEEDING SPECIFICATIONS

When

- To finalize stabilization of temporary seeding areas or when an area needs permanent stabilization following completion of construction. Also used when vegetative establishment can correct existing soil erosion or sedimentation problem.
- Within 5 days of final grade.

Why

- To stabilize soil and prevent or reduce soil erosion/sedimentation problems from developing.

Where

- Used on construction and earth change sites which require permanent vegetative stabilization.

How

1. Review SESC plan and construction phasing to identify areas in need of permanent vegetative stabilization.
2. Select perennial grass and ground cover for permanent cover.
3. Seed mixes vary. However, they should contain native species.
4. Seed mixes should be selected through consultation with a certified seed provider and with consideration of soil type, light, moisture, use applications, and native species content.
5. Soil tests should be performed to determine the nutrient and pH levels in the soil. The pH may need to be adjusted to between 6.5 and 7.0.
6. Prepare a 3–5” deep seedbed, with the top 3–4” consisting of topsoil.
7. Slopes steeper than 1:3 should be roughened.
8. Apply seed as soon as possible after seedbed preparation. Seed may be broadcast by hand, hydroseeding, or by using mechanical drills.
9. Mulch immediately after seeding.
10. Dormant seed mixes are for use after the growing season, using seed which lies dormant in the winter and begins growing as soon as site conditions become favorable.

STANDARD SYMBOL



**GRAND VALLEY
STATE UNIVERSITY.**

PERMANENT SEEDING SPECIFICATIONS



How
(cont.)

11. Protect seeded areas from pedestrian or vehicular traffic.
12. Divert concentrated flows away from the seeded area until vegetation is established.

Maintenance

- Inspect weekly and within 24 hours following each rain event in the first few months following installation to be sure seed has germinated and permanent vegetative cover is being established.
- Add supplemental seed as necessary.

Limitations

- Seeds need adequate time to establish.
- May not be appropriate in areas with frequent traffic.
- Seeded areas may require irrigation during dry periods.
- Seeding success is site specific, consider mulching or sodding when necessary.



**GRAND VALLEY
STATE UNIVERSITY.**

PERMANENT SEEDING

<u>Planting Zones:</u>	Lower Peninsula (South of T20N) Zone 1	Lower Peninsula (North of T20N) Zone 2	Upper Peninsula Zone 3
<u>Seeding Window</u> Permanent Seeding	4/15 – 10/10	5/1 – 10/1	5/1 – 9/20
<u>Seeding Window</u> Dormant Seeding*	11/15 – Freeze	11/01 – Freeze	11/01 – Freeze

Source: Adapted from MDOT Interim 2003 Standard Specifications for Construction

	<u>Zone 1</u> Lower Peninsula (South of U.S. 10)	<u>Zone 2</u> Lower Peninsula (North of U.S. 10)	<u>Zone 3</u> Upper Peninsula
<u>Seeding Dates</u> (with Irrigation or Mulch)	4/1 – 8/1	5/1 – 9/20	5/1 – 9/10
<u>Seeding Dates</u> (w/o Irrigation or Mulch)	4/1 – 5/20 or 8/10 – 10/1	5/1 – 6/10 or 8/1 – 9/20	5/1 – 6/15 or 8/1 – 9/20
<u>Dormant Seeding Dates*</u>	11/1 – Freeze	10/25 – Freeze	10/25 – Freeze

Source: Adapted from USDA NRCS Technical Guide #342 (1999)

* Dormant seeding is for use in the late fall after the soil temperature remains consistently below 50°F, prior to the ground freezing. This practice is appropriate if construction on a site is completed in the fall but the seed was not planted prior to recommended seeding dates. No seed germination will take place until spring. A cool season annual grass may be added in an attempt to have some fall growth.

- Mulch must be used with dormant seed.
- Do not seed when the ground is frozen or snow covered.
- Do not use a dormant seed mix on grassed waterways.

MULCH BLANKETS

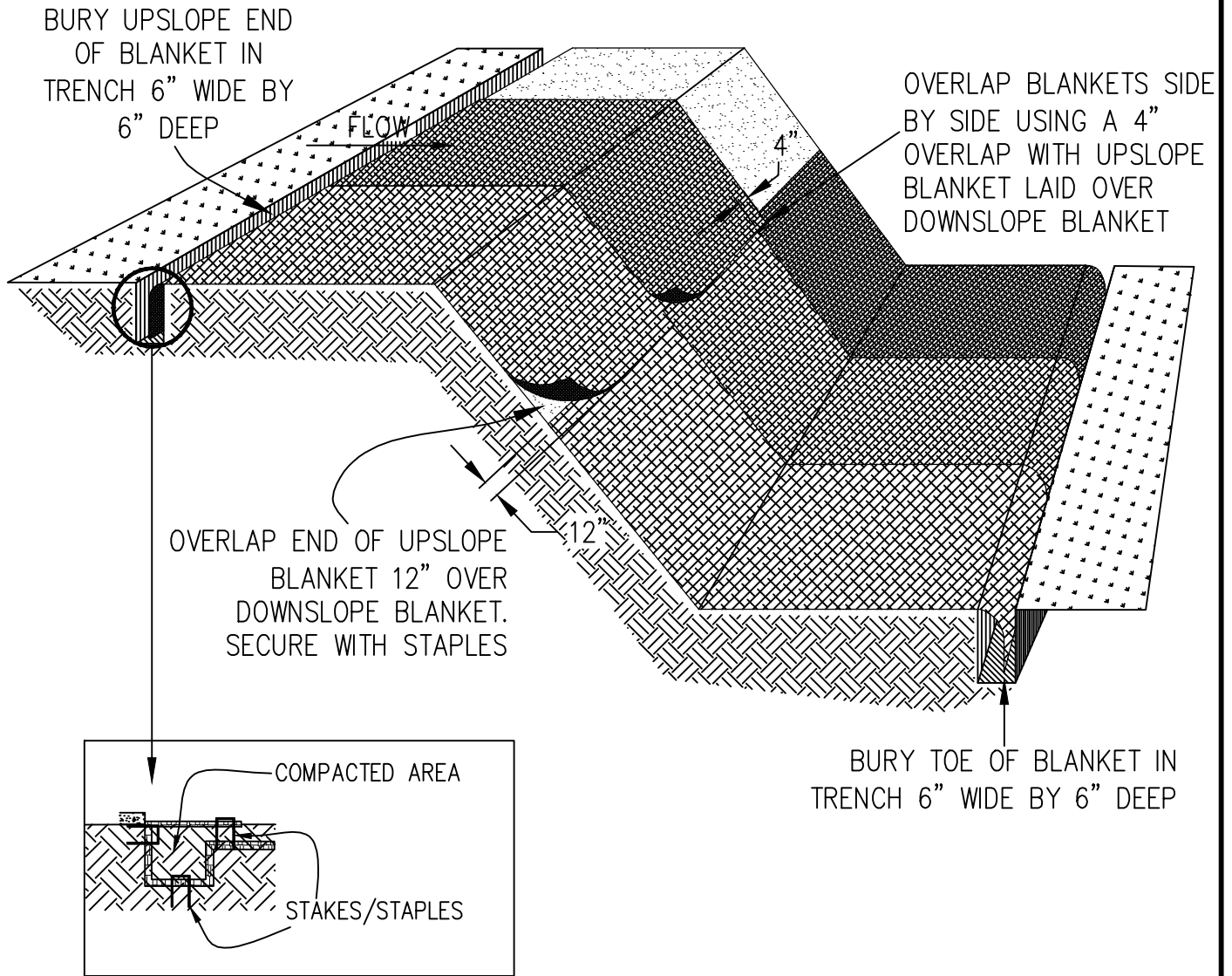

- NOTES:
- ① PLACE MULCH BLANKET PARALLEL TO FLOW AND ANCHOR SECURELY.
 - ② WHEN BLANKETS ARE USED IN FLOWING DITCH, BLANKETS SHOULD NOT OVERLAP IN DITCH CENTER PARALLEL TO FLOW.
 - ③ STAPLES INSTALLED/SECURED ACCORDING TO MANUFACTURER'S SPECIFICATIONS.
 - ④ WHERE POSSIBLE, CONSTRUCT WITH BIODEGRADABLE MATERIAL.

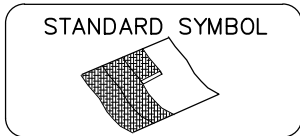



MULCH BLANKETS SPECIFICATIONS

- When
- When seeded areas are subject to erosive surface flows, severe wind, or to protect non-vegetated slopes or areas during the winter.
- Why
- Protects seeded areas and slopes against erosion from rain or wind. Holds soil moisture to allow for seed germination and reduces wind desiccation of germinated seeds.
- Where
- Use on exposed slopes, newly seeded areas, new ditch bottoms, and other areas subject to erosion.
- How
1. Prepare subgrade to proper grade and compaction requirements.
 2. Remove ruts, roots, soil clods, or other debris from surface subject to mulch blanket installation.
 3. Spread or drill seed.
 4. Consult with erosion control material supplier to select mulch blanket based on slope gradient, expected surface run-off, and protection term necessary (long or short term).
 5. Position selected mulch blanket as close as possible to intended use location.
 6. Install blanket at top of slope, first anchoring toe in trench 6" wide X 6" deep, progressing down-slope or down-gradient with approximately 12" of blanket extended beyond the up-slope portion of the trench.
 7. Anchor the blanket with staples/stakes placed approximately 12" apart in the bottom of the trench. Backfill and compact the trench after securing.
 8. Apply seed to compacted soil and fold the 12" portion of the blanket over compacted area and secure with a row of staples/stakes placed 12" apart across the width of the blanket.
 9. Unroll the blankets down or horizontally across the slope.





MULCH BLANKETS SPECIFICATIONS

How
(cont.)

10. Overlap blanket edges by a minimum of 4" and blanket ends by a minimum of 12". Overlaps should be in the direction of expected flow with the up-slope blanket placed over the down-slope blanket edge.
11. Secure down-slope end of blanket with staples/stakes and trench in.

Maintenance

- Check after a rain event to ensure the blanket is still in place.
- Keep eroded soil, vehicular and pedestrian traffic, and concentrated runoff away from the blanketed area.

Limitations

- Mulch blankets and anchors may inhibit mowing.



**GRAND VALLEY
STATE UNIVERSITY.**

E10

SODDING

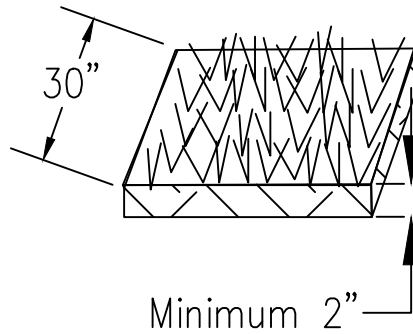

INDIVIDUAL SOD SECTION

APPLY IN ROWS AT RIGHT ANGLES TO SLOPE DIRECTION

LAY SOD IN A STAGGERED PATTERN. BUTT STRIPS TIGHTLY TOGETHER.

GRADE AREA AND REMOVE ALL DEBRIS

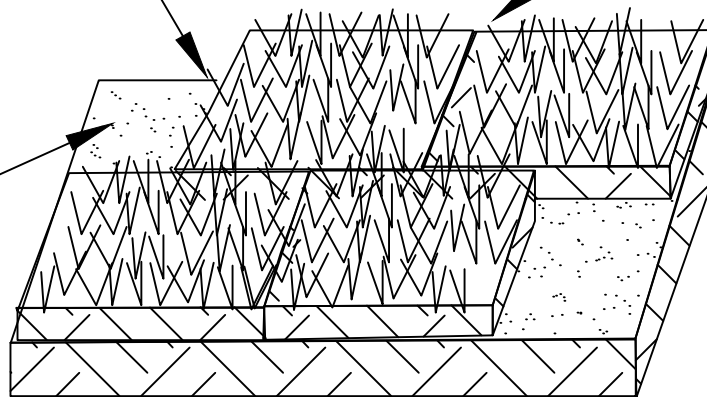

STANDARD SYMBOL

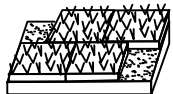

**GRAND VALLEY
STATE UNIVERSITY.**

SODDING SPECIFICATIONS

- When
- When immediate vegetative cover is needed on exposed areas.
- Why
- To provide immediate cover.
- Where
- Apply on exposed areas/slopes where vegetative stabilization is needed sooner than can be established by seeding and where irrigation is available.
- How
1. Prepare area by grading and removal of sticks, rocks, roots, soil clods, and construction debris.
 2. Complete soil testing to determine pH and nutrient content of soil.
 3. Apply soil amendments as necessary per soil testing.
 4. Select sod type based on expected exposure and moisture regimes, planned maintenance level, and intended use.
 5. Strips of sod should be uniform in width with strips free of weeds.
 6. Cultured sod should be approximately 0.5" thick and not less than 30" in length. Other grass sods should be cut at least 2" thick and in strips at least 10" by 18".
 7. Apply sod in rows perpendicular to slope direction.
 8. Apply sod perpendicular to waterflow direction on slopes or in flow paths.
 9. Place sod pieces immediately adjacent to one another with no open joints left between strip edges or ends.
 10. Stagger ends of adjacent sod strips to minimize concentrated flow at joints.
 11. Roll or tamp sod immediately after installation.
 12. On slopes steeper than 1:3, or in areas of concentrated flows, secure sod with 10" wood stakes or pegs spaced 2 feet apart, driven flush with the sod surface.
 13. Water sod to thoroughly moisten soil.
 14. Withhold traffic from recently sodded area until sod is firmly established.





SODDING SPECIFICATIONS

Maintenance

- Inspections should occur frequently for the first few months to ensure the sod is established.
- New pieces of sod may need to be laid out, as well as the application of fertilizer or the pH content of the soil retested.

Limitations

- Sod can be laid between May 1 and October 20. Between June 10 and September 10 irrigation is necessary.
- May require irrigation.
- Pedestrian traffic must be diverted until sod is established.
- Sod installation is more costly and labor intensive than seeding.



E11

VEGETATED CHANNELS

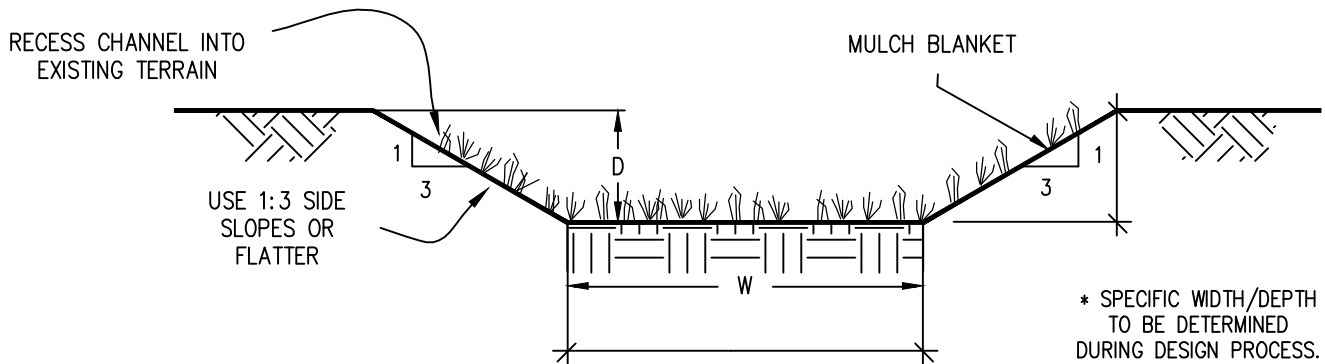

CHANNEL CROSS-SECTION

CHANNEL SHAPES:

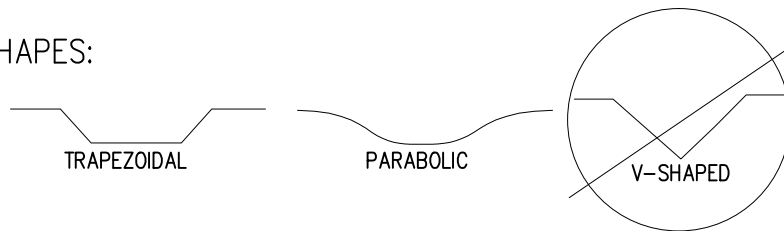

SOIL ERODIBILITY	
SOIL TEXTURE	ERODIBILITY
SILT, SAND, LOAM, SILTY LOAM, SANDY LOAM	EASILY ERODIBLE
CLAY LOAM, SILTY CLAY LOAM, SANDY CLAY LOAM, SILT LOAM, CLAY	EROSION RESISTANT SOILS

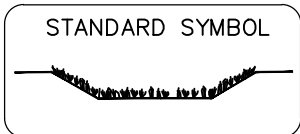

NOTES:

1. LOCATE VEGETATED CHANNELS TO FOLLOW NATURAL TOPOGRAPHY
2. UTILIZE PARABOLIC OR TRAPEZOIDAL CHANNEL SHAPES.
3. AVOID V-SHAPED CHANNELS AS THEY PROMOTE EROSION.
4. SELECT APPROPRIATE VEGETATION BASED ON RETARDANCE TO REDUCE FLOW VELOCITIES.
5. MAY NEED MULCH BLANKET or TURF REINFORCEMENT MATS (TRM'S) IN HIGH VELOCITY FLOW AREAS OR DITCH BOTTOMS.



VEGETATED CHANNELS SPECIFICATIONS

E11

- When
- When surface flow velocities within a created stormwater channel have the potential to cause erosion.
- Why
- To slow water velocity and reduce erosion and sediment loading in the stormwater channel.
- Where
- For use in constructed drainageways where run-off may cause erosion.
- How
1. Review subject site to identify channel areas potentially susceptible to high flows, erosive velocities or flooding.
 2. Consult a professional landscape architect, professional engineer or CPESC regarding considerations of channel design based on water velocity, channel slope, discharge volume, and soil type.
 3. General capacity requirements should allow for conveyance of a 10-year, 24-hour rain event at a minimum, unless local requirements exceed this minimum.
 4. Channel shape should either be parabolic  or  trapezoidal. V-shaped channels are not recommended as they form gullies and increase the erosion potential.
 5. All vegetated channels should have a depth of one foot or more.
 6. Excavate or grade channel surface according to design. Locate channels in natural topographic depressions where possible. Recess channel into existing grade so that channel top is flush with adjacent grade.
 7. Determine vegetative species based on the depth to water table, climate, anticipated flow velocities, and final managed length of vegetation. Utilize native species for vegetation purposes.
 8. In channels to be seeded, prepare seedbed, apply seed, and install mulch blanket/TRM.
 9. In channels planted with vegetative plugs or seedlings, prepare channel, and install mulch blanket/TRM.



**GRAND VALLEY
STATE UNIVERSITY.**



VEGETATED CHANNELS SPECIFICATIONS

How
(cont.)

10. Not recommended to use dormant seedings due to high failure rate.
11. Establish vegetated channel prior to periods of high run-off.
12. Prior to construction work in area surrounding channel, allow vegetation in channel to establish.
13. Check dams or velocity dissipators may be needed until vegetation is established.

Maintenance

- Inspect periodically during establishment of vegetation to ensure vegetative establishment is successful.
- Inspect after each rain event during vegetative establishment period for erosion problems.
- If necessary, repair, replant, reseed eroded areas immediately.
- Remove sediment concentrations that occur in vegetated channel.
- Remove fallen woody debris that may direct flows out of vegetated channel.

Limitations

- In constructed channels, additional protective measures may be required prior to establishment of vegetation.



**GRAND VALLEY
STATE UNIVERSITY.**

RIPRAP

STREAM BANK APPLICATION

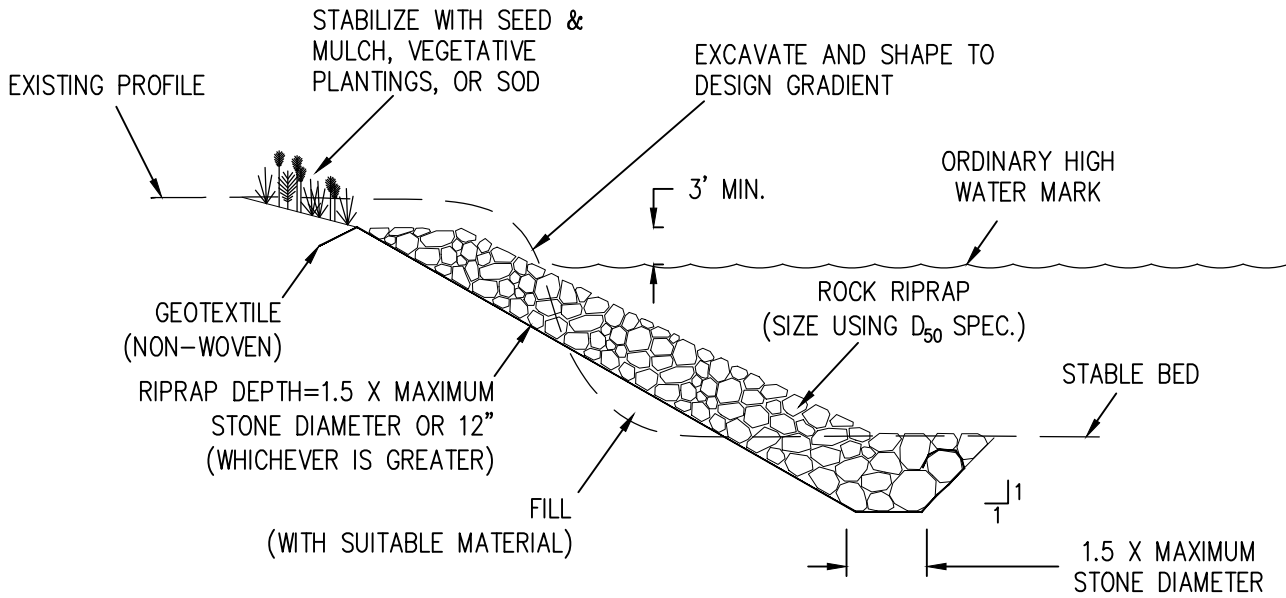

OUTLET POINT APPLICATION

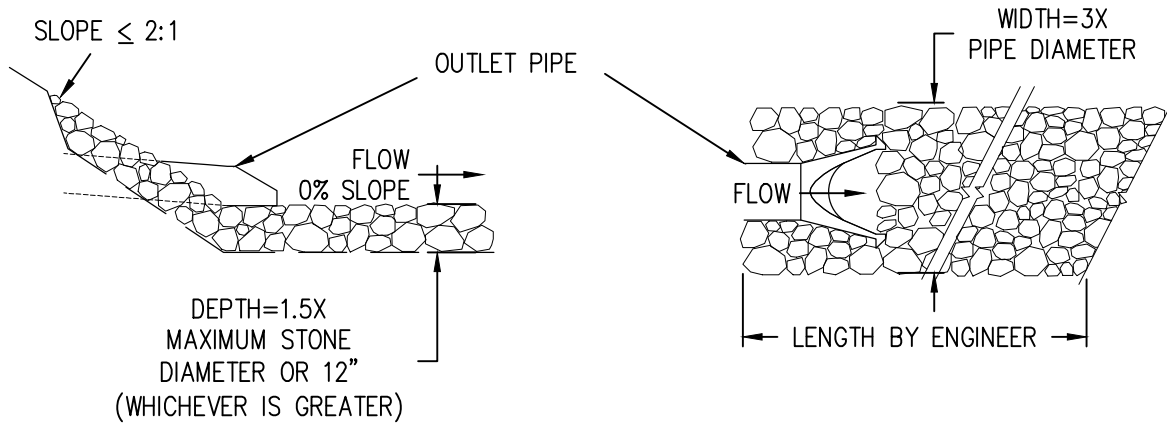

STANDARD SYMBOL



GRAND VALLEY
STATE UNIVERSITY

RIPRAP SPECIFICATIONS

- When
- When concentrated water flows have the potential to create scour, down-cutting, or lateral cutting.
- Why
- To prevent loss of land or damage to utilities or structures. In aquatic applications, riprap is used to control channel meander and maintain capacity, protect against wave attack, and reduce sediment load.
- Where
- In natural or constructed channels with areas susceptible to erosion from the action of water, ice, or debris, or to damage by livestock or vehicular traffic.
 - In shoreline areas where the erosion problem may be solved through simple structural measures.
 - On slopes with profiles measuring 1:1.5 or less.
- How
1. Review subject site to identify areas subject to concentrated flows or wave/current attack.
 2. The appropriateness and extent of riprap placement is site specific and should be determined in the field.
 3. The area under review for riprap placement must be shaped and contoured appropriately by grading prior to material placement.
 4. Non-woven geotextile fabric should be installed prior to riprap placement, with upper end and toe end of fabric buried or anchored to prevent movement.
 5. Riprap placement should be started at a stabilized location and ended at a stabilized or contoured point.
 6. Material selected for riprap should be hard, angular, and resistant to weathering. Appropriate material size depends on expected water energy and intended function of the material.



RIPRAP SPECIFICATIONS

How
(cont.)

7. Riprap mixture should be an even mixture of stone sizes based on the average, or D_{50} . This means 50% of the stone, by size, will be larger than the diameter specified, and 50% will be smaller than the size specified. The diameter of the largest stone should not be more than 1.5 times the D_{50} stone size.
8. See table on the following page for typical riprap stone sizes.
9. Rock shall be placed so that larger rocks are uniformly distributed and in contact with one another. Smaller rocks should fill the voids.
10. When in contact with moving water, riprap will tie into a stable bank at the downstream end and will be keyed into the bank at the upstream end. Riprap should extend 3 ft. above the ordinary high water mark or to the top of the bank on short slopes. Extend riprap a minimum 10 ft. beyond active erosion area.

Maintenance

- All installations should be inspected immediately after the first rainfall to confirm the stability of the placed material. Follow-up inspections should occur regularly and provisions made for prompt repair if needed.

Limitations

- Area is cleared prior to the addition of riprap, therefore no areas are preserved with native vegetation.

SIZE OF TYPICAL RIPRAP STONES			
Weight (lbs.)	Average Spherical	Typical Rectangular Shape	
	Diameter (in.) D_{50}	Length (in.)	Width/Height (in.)
50	10	18	6
100	13	21	7
150	14	24	8
300	18	30	10
500	22	36	12
1000	27	45	15
1500	31	52	17
2000	34	57	19
4000	43	72	24
6000	49	83	28
8000	54	90	30

Source: Adapted from USDA NRCS



GABION WALLS

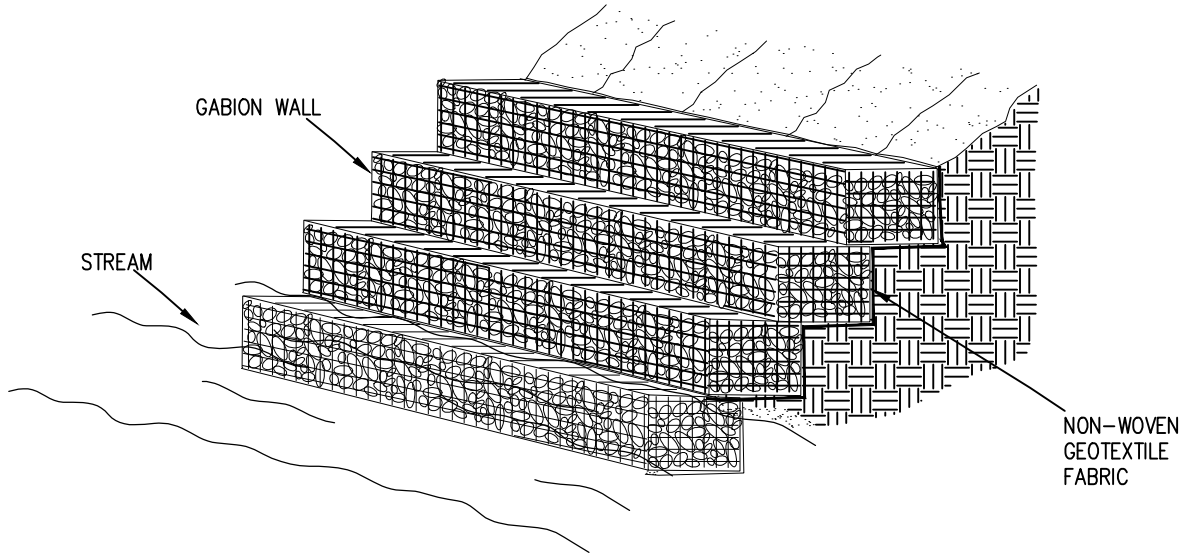

OBLIQUE VIEW

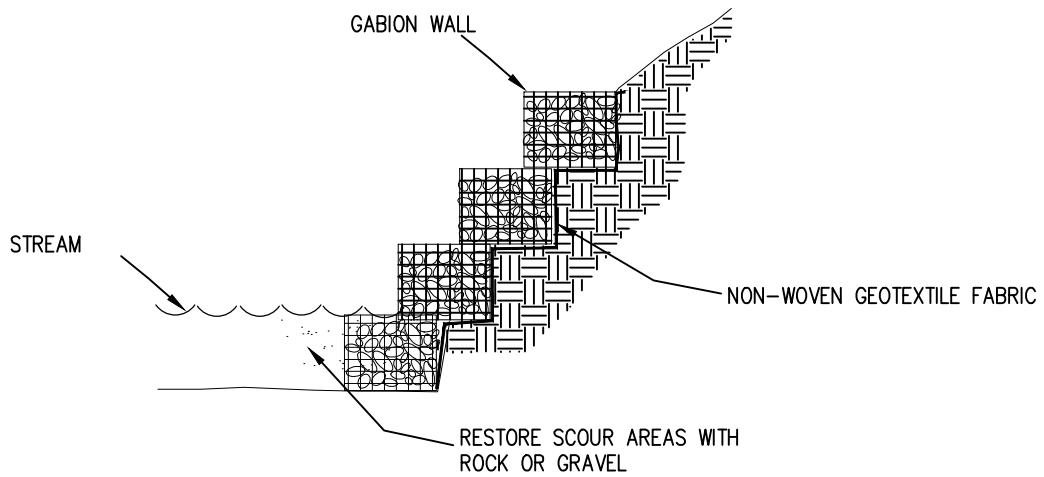

CROSS-SECTION

STANDARD SYMBOL



GABION WALLS SPECIFICATIONS

- When**
- When flow velocities are resulting in major bank or slope failure.
- Why**
- To stop and then minimize soil erosion on stream banks.
- Where**
- On existing stream banks to address or prevent surface velocity caused erosion.
 - On slopes which are too steep for standard rip-rap (greater than 1:2).
- How**
1. Remove loose material to provide a firm foundation for gabion baskets.
 2. Wire mesh which makes up the gabion basket should be no smaller than 12 gauge. Mesh size will vary on rock size used to fill the basket. 9 gauge wire should be used for all ties and lacing.
 3. Place non-woven geotextile fabric on bank to prevent loss of fine grained soils into gabions. Secure ends at least every 8" along seams. A minimum of 2 ties should be made between gabions for every square foot of contact area.
 4. Fill voids between excavation line or bank with gravel and cobble fill
 5. Gabion installation to begin and end at stable bank points.
 6. Provide loose rock riprap transition zones if necessary.
 7. Install only single row of gabions for low bank (3'±) protection. Utilize multiple rows fastened together for high bank protection.
- Maintenance**
- Inspect gabion locations annually following spring or peak water flows and following each 100 year storm occurrence.
 - Repair gabions immediately upon inspection to prevent undercutting or stream bank failure.
- Limitations**
- Gabion walls are not as aesthetically pleasing as vegetated areas.
 - High construction costs may limit the applicability on some work sites.

ENERGY DISSIPATER

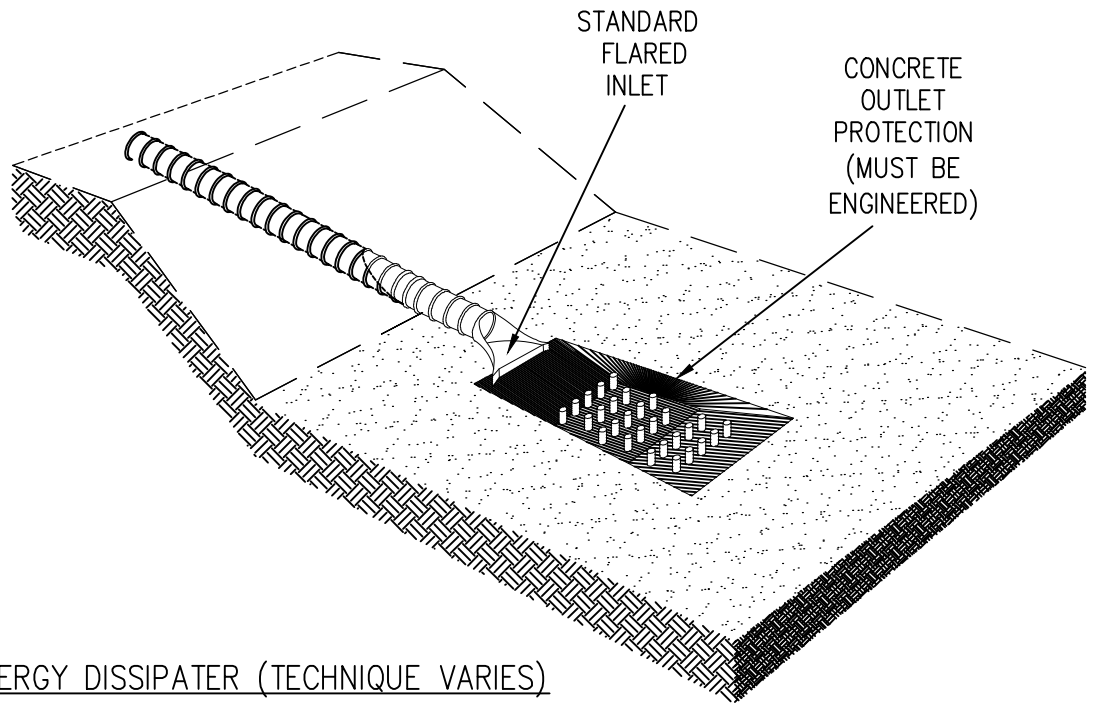

ENERGY DISSIPATER (TECHNIQUE VARIES)

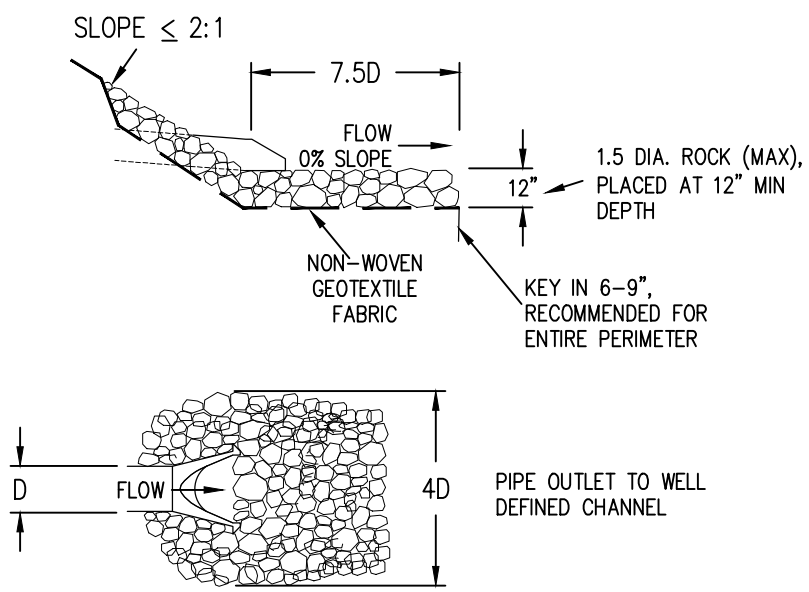

ROCK RIP-RAP DISSIPATER

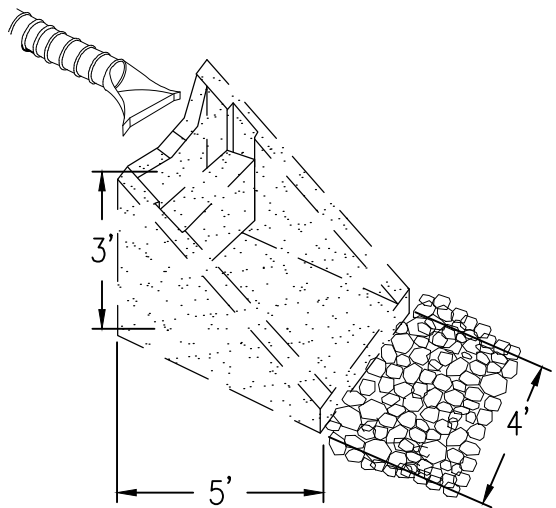

CONCRETE DISSIPATER

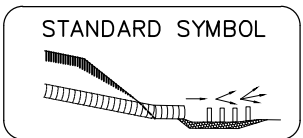

NOTE: RIPRAP SHOULD BE SIZED BY A PROFESSIONAL ENGINEER OR CPESC BASED ON EXPECTED MAXIMUM ENERGY



ENERGY DISSIPATER SPECIFICATIONS

- When
- Used at outlets of culverts, drainage pipes, or other conduits when flow velocities have the potential to scour at outlet point.
- Why
- To protect against scouring at a culvert end section and to reduce discharge flow velocities to non-erosive levels.
- Where
- Where the energy transmitted from a concentrated flow of surface runoff is sufficient to erode receiving area and/or watercourse.
- How
1. Review project plans to identify concentrated discharge points likely to carry runoff velocities capable of scouring receiving outlet points.
 2. Project engineer or CPESC to design appropriate energy dissipater based on anticipated culvert outlet velocity.
 3. Unless otherwise specified, dissipater should be sufficient to handle peak runoff from a 10-year, 24 hour rainfall event.
 4. Dissipater apron should be sized for outflow rate and expected tailwater level (if applicable).
 5. Dissipater to be constructed with alignment square to receiving watercourse, with dissipater kept straight throughout entire length.
 6. For riprap lined dissipaters, rip-rap should be placed on non-woven geotextile fabric toed in a minimum of 6-9" along the entire perimeter.
 7. Depth of rock should be 1.5 times maximum rock diameter, placed on non-woven geotextile fabric.
 8. Concrete dissipater to be installed square with receiving watercourse, per manufacturer directions.



E14

ENERGY DISSIPATER SPECIFICATIONS

- Maintenance
- Structure must be inspected regularly and after storms.
 - Remove sediment/debris accumulation regularly.
 - Dissipation of erosive velocity at outlet must be maintained. If necessary, increase size or number of dissipators and enlarge outlet structure proportionately.
- Limitations
- Large storms often wash away the rock outlet protection and leave the area susceptible to erosion.
 - Sediment captured by the rock outlet protection may be difficult to remove without removing the rock.
 - Outlet protection may negatively impact the channel habitat.



**GRAND VALLEY
STATE UNIVERSITY.**

TEMPORARY SLOPE DRAIN

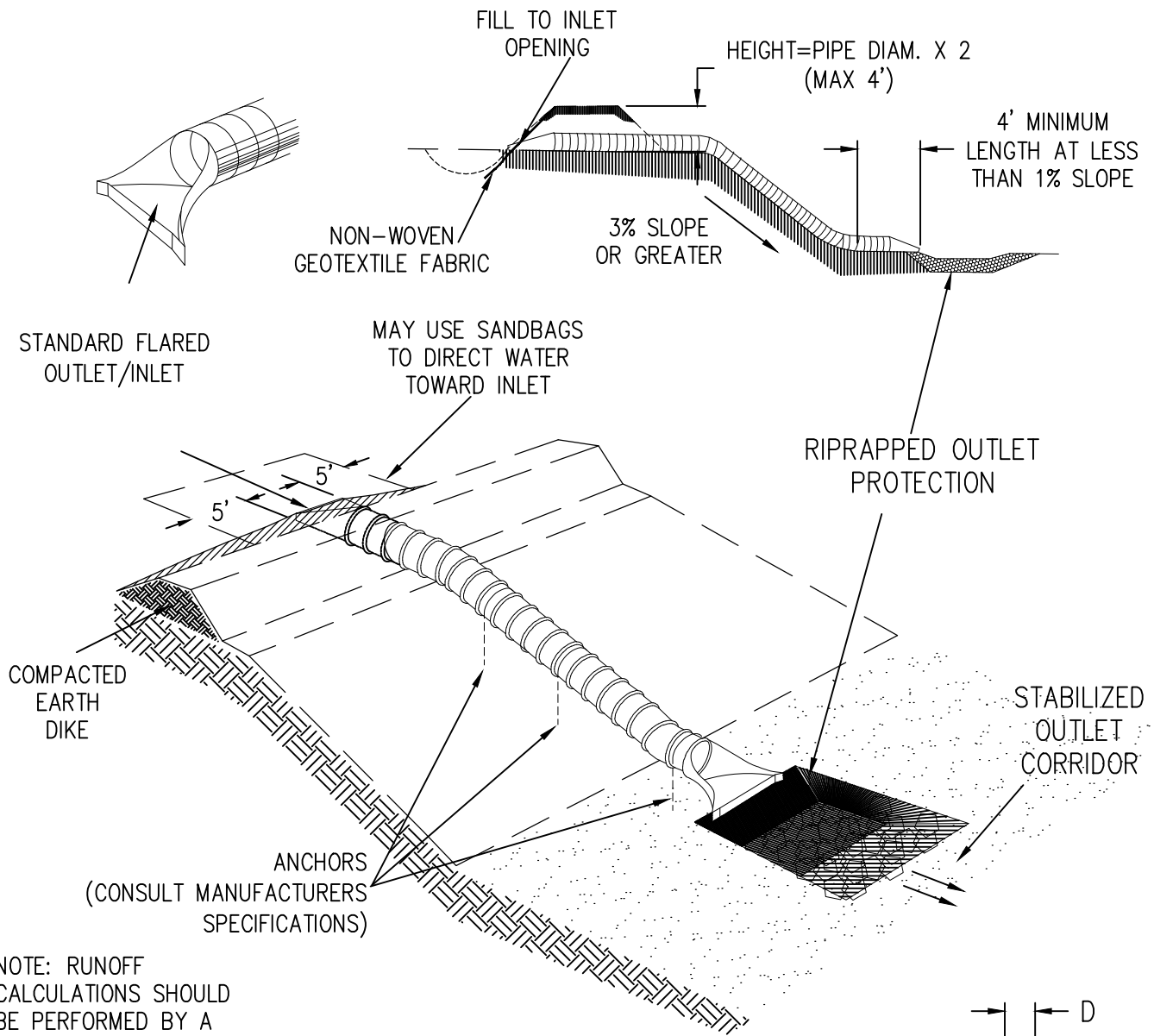

NOTE: RUNOFF CALCULATIONS SHOULD BE PERFORMED BY A PROFESSIONAL ENGINEER OR CPESC TO DETERMINE APPROPRIATE PIPE SIZING AND OUTLET CHARACTERISTICS (RIPRAP SIZE, ETC.)

DESIGN CRITERIA FOR PIPE SLOPE DRAIN

(PIPE TO BE SPECIFIED BY ENGINEER)

PIPE DIAMETER (IN.)	MAXIMUM DRAINAGE AREA (ACRES)
12	0.5
18	1.5
21	2.5
24	3.5
(2) 24	5.0

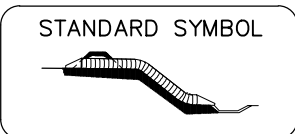
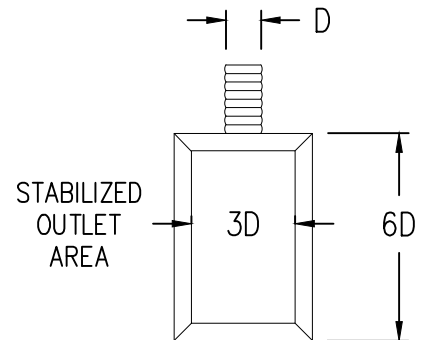

SOURCE: MARYLAND DEPT. OF ENVIRONMENT--WATER MANAGEMENT DIVISION



E15

TEMPORARY SLOPE DRAIN SPECIFICATIONS

Maintenance
(cont.)

- Dissipation of erosive velocity at outlet must be maintained.
- Pipe anchors must be maintained to ensure pipe is properly anchored.

Limitations

- Large drainage areas may require utilization of multiple slope drains to handle water volume.
- Requires further stabilization of pipe corridor after removal.



**GRAND VALLEY
STATE UNIVERSITY.**

TEMPORARY SLOPE DRAIN SPECIFICATIONS

E15

When	<ul style="list-style-type: none">• When surface runoff must be conveyed down a slope to prevent erosion.
Why	<ul style="list-style-type: none">• To reduce or eliminate slope erosion until permanent treatments are installed and the slope is stabilized.
Where	<ul style="list-style-type: none">• At tops of slopes: To provide drainage for top of slope diversion dikes or swales. To provide drainage for top of cut/fill slopes where water can accumulate.
How	<ol style="list-style-type: none">1. Identify runoff concentration points occurring at the top of unstable slopes, at discharge points from diversion berms or dikes, and at outlets for sediment basins at the top of slopes.2. Select appropriate pipe size. Size should be sized by engineer or CPESC and should not be less than specified in design criteria table. Unless otherwise specified, temporary drains should be sufficient to handle peak runoff from a 10-year, 24-hour rainfall event.3. Construct the pipe slope drain entrance using a standard flared end section with a minimum 6-inch metal toe plate to prevent runoff from undercutting the pipe inlet. The slope of the entrance is usually at least 3 percent. Use non-woven geotextile under entrance to prevent infiltration.4. Thoroughly compact the soil around and under the pipe and entrance section. Securely fasten the slope drain sections together and securely anchor into the soil.5. Stabilize outlet with riprap. Riprap should consist of 6" diameter stone placed according to volume of discharge expected.
Maintenance	<ul style="list-style-type: none">• Structure must be inspected regularly and after storms. A clogged slope drain will force water around pipe and cause slope erosion.• Inlet must be free of undercutting and no water should seep past entry.



**GRAND VALLEY
STATE UNIVERSITY.**

SLOPE DRAIN – SUBSURFACE

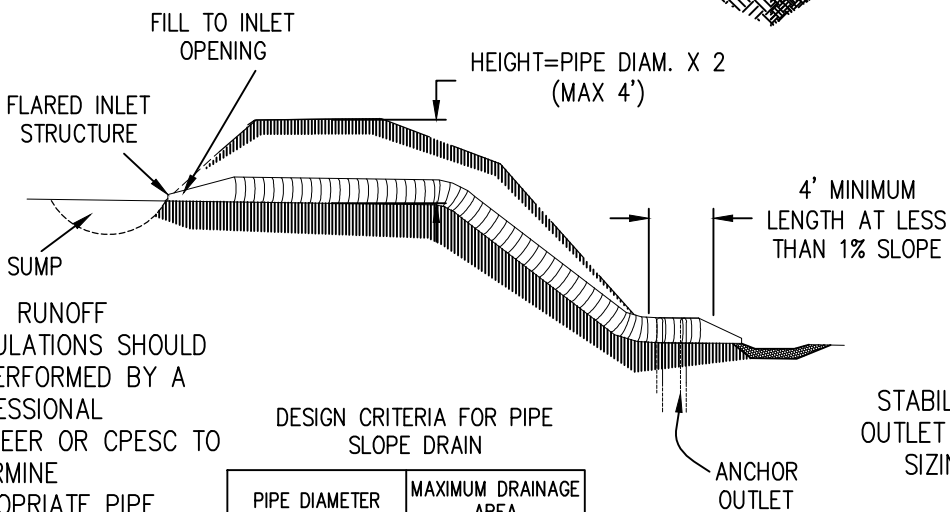
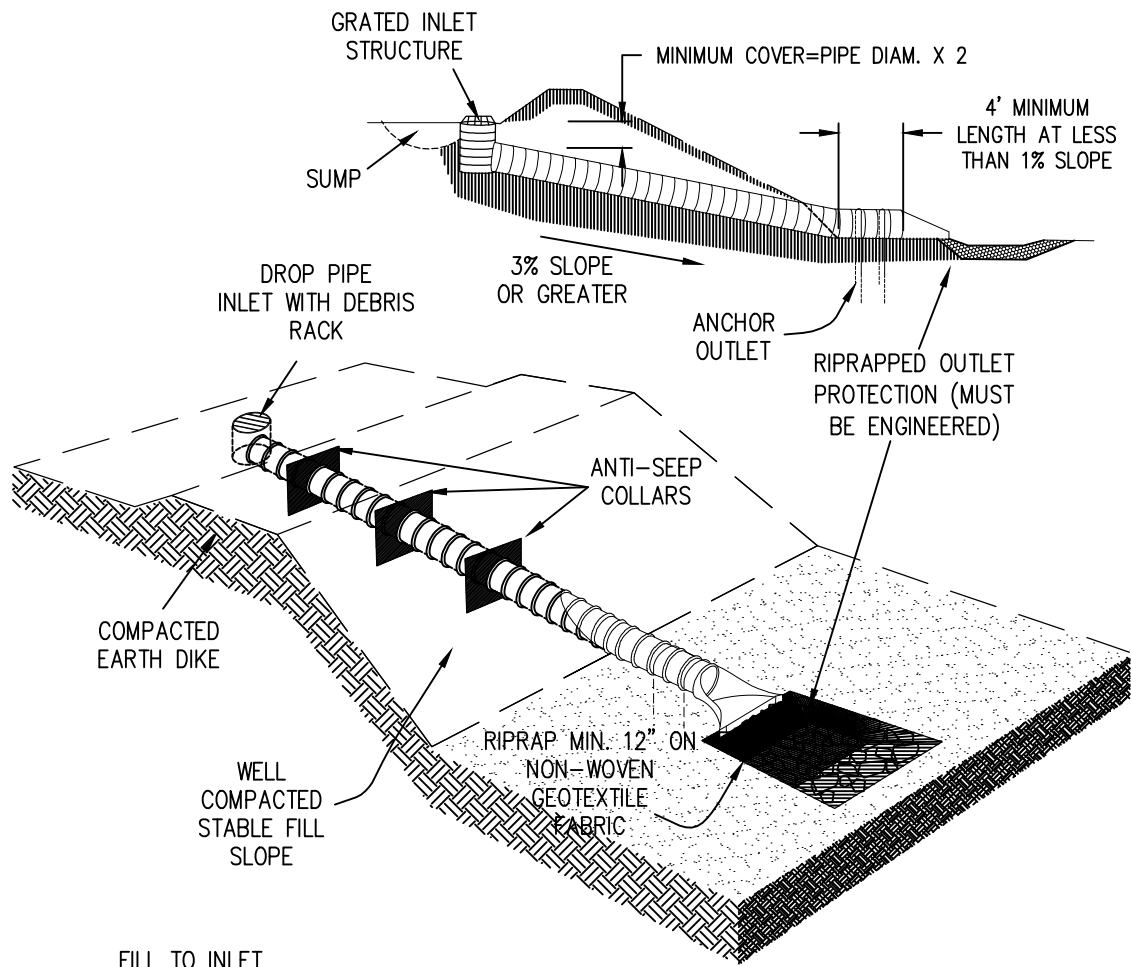

NOTE: RUNOFF CALCULATIONS SHOULD BE PERFORMED BY A PROFESSIONAL ENGINEER OR CPESC TO DETERMINE APPROPRIATE PIPE SIZING AND OUTLET CHARACTERISTICS (RIPRAP SIZE, ETC.)

DESIGN CRITERIA FOR PIPE SLOPE DRAIN

PIPE DIAMETER (IN.)	MAXIMUM DRAINAGE AREA (ACRES)
12	0.5
18	1.5
21	2.5
24	3.5
(2) 24	5.0

SOURCE: MARYLAND DEPT. OF ENVIRONMENT--WATER MANAGEMENT DIVISION

STANDARD SYMBOL





SLOPE DRAIN – SUBSURFACE SPECIFICATIONS

Maintenance
(cont.)

- Inspect outlet velocity dissipation devices to prevent outlet point damage. Remove accumulated debris/sediment.
- Inspect pipe anchor points regularly to prevent system failure.

Limitations

- Most suitable for permanent rather than temporary applications.
- Subsurface application is more costly than surface applications.
- Failure to adequately anchor subsurface outlet may result in significant erosion.



**GRAND VALLEY
STATE UNIVERSITY.**

SLOPE DRAIN – SUBSURFACE SPECIFICATIONS

E16

- When
- When surface runoff accumulates at the top of a slope and requires permanent conveyance to slope bottom to minimize erosion.
- Why
- To eliminate slope erosion, gully formation, and slope failure.
- Where
- Where concentrated flow of surface runoff must be permanently conveyed down a slope in order to prevent erosion.
 - To provide permanent drainage for top of slope diversion dikes or swales.
- How
1. Utilize grading plan to identify permanent slope top runoff/stormwater concentration points.
 2. Site engineer or landscape architect to design subsurface slope drain system.
 3. Select appropriate pipe size. Size should not be less than specified in design criteria table. Unless otherwise specified, temporary drains should be sufficient to handle peak runoff from a 10–year, 24–hour rainfall event.
 4. Construct the pipe slope drain entrance using a drop pipe with a screened inlet (alternative: a standard flared inlet). The slope of the entrance is usually at least 3 percent.
 5. Utilize anti–seep watertight collars to join pipe sections.
 6. Thoroughly compact the soil around and under the pipe and entrance section in multiple lifts.
 7. Stabilize outlet with riprap. Riprap should consist of 6” diameter stone placed according to volume of discharge expected.
- Maintenance
- Structure must be inspected periodically after stabilization and routinely during construction.
 - Inlet must be free of undercutting and no water should seep past entry.



**GRAND VALLEY
STATE UNIVERSITY.**

E17

CELLULAR CONFINEMENT SYSTEM

* ALL EARTH PROTECTION SYSTEMS TO BE DESIGNED BY A PROFESSIONAL ENGINEER or CPESC

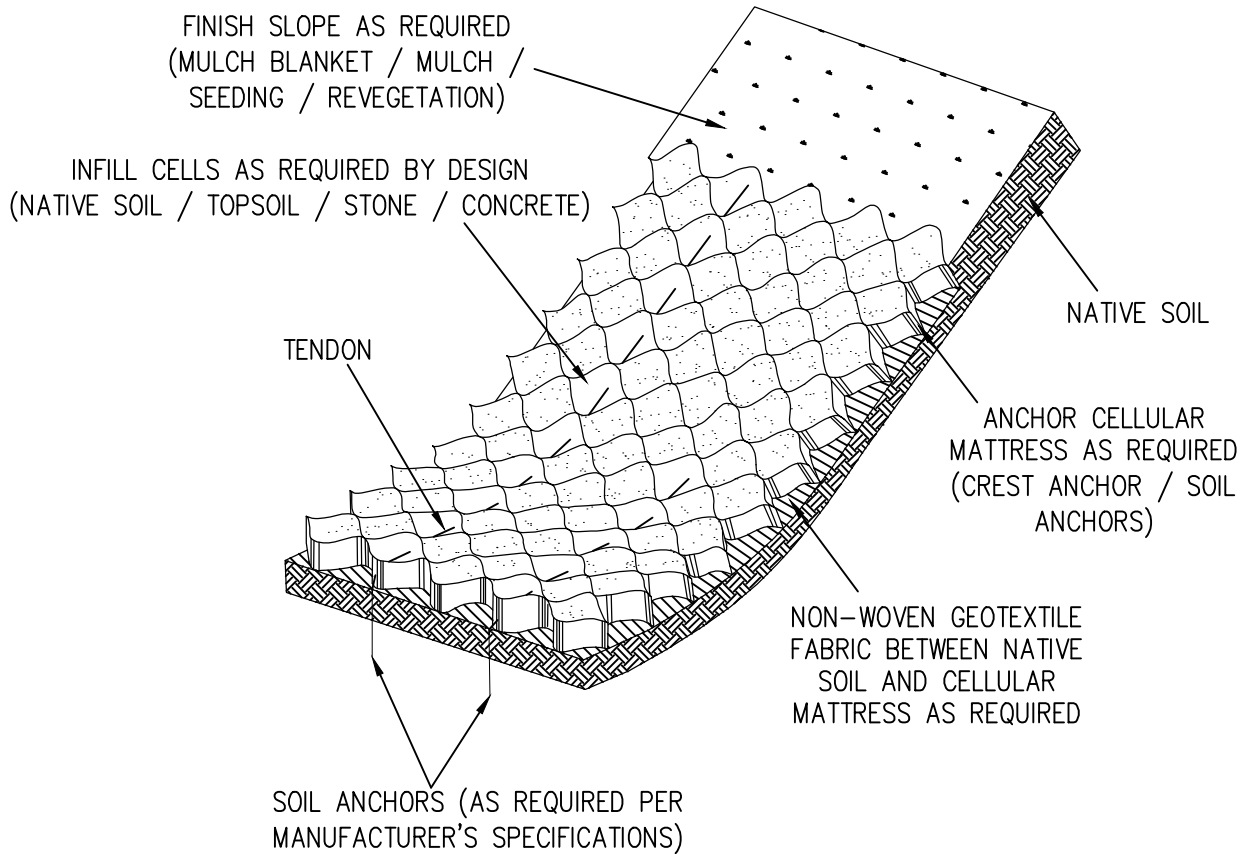

SLOPE PROTECTION

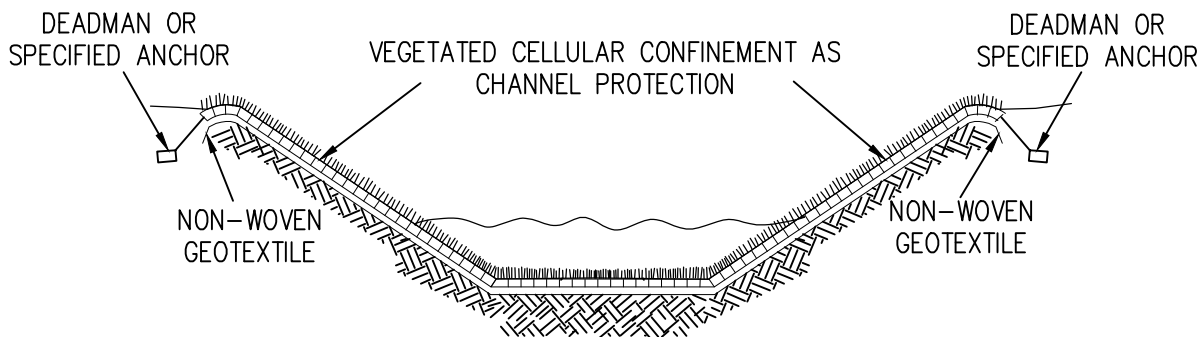

CHANNEL PROTECTION

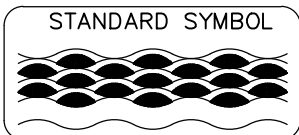

CELLULAR CONFINEMENT SYSTEM

* ALL EARTH PROTECTION SYSTEMS TO BE DESIGNED BY A PROFESSIONAL ENGINEER or CPESC.

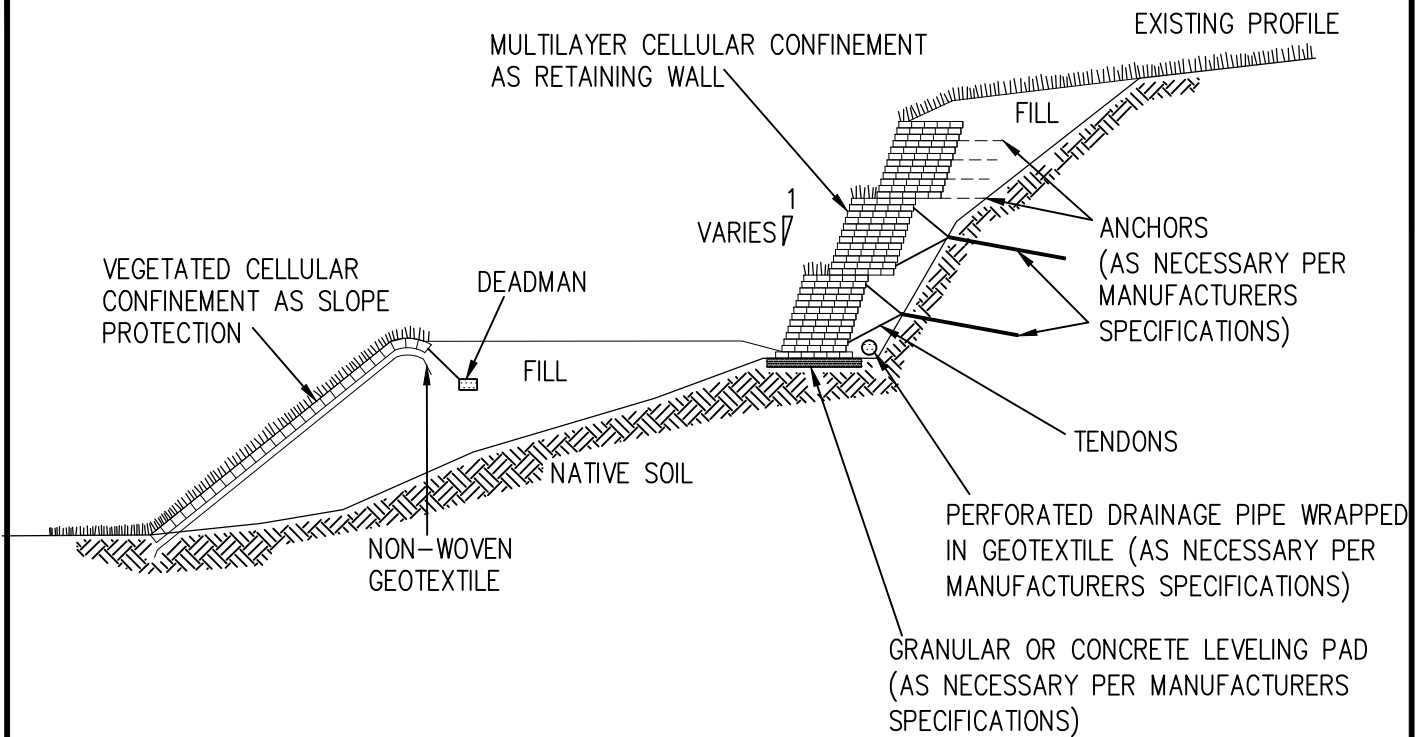

EARTH RETENTION – TYPICAL APPLICATIONS

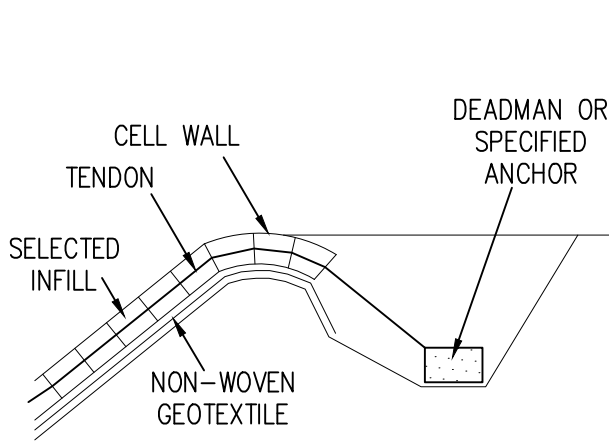

DEADMAN CREST ANCHORAGE

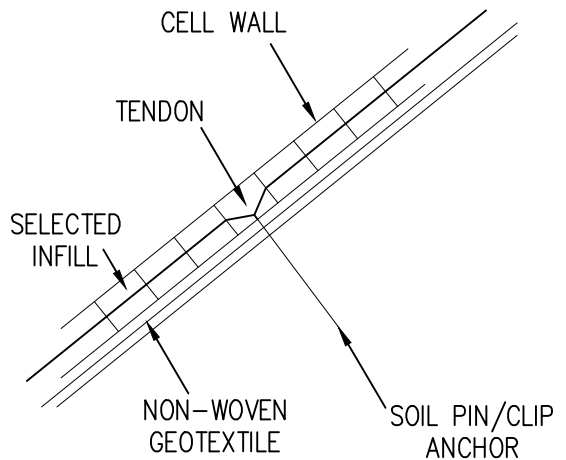

SOIL PIN/CLIP SURFACE ANCHORAGE

SLOPE PROTECTION – GROUND ANCHORS

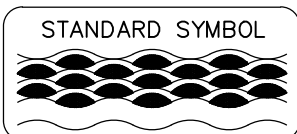



CELLULAR CONFINEMENT SYSTEM SPECIFICATIONS

- When
- Provides permanent slope or channel protection and earth retention while confining area of impact.
- Why
- To inhibit soil movement and preserve natural drainage. Allows for use of native fill and revegetation.
- Where
- In areas requiring permanent stabilization of steep grades within a narrow area of impact.
 - In channels with high velocity flows.
 - As an alternative to wood, steel, concrete, or block retaining walls, particularly when the ability to support vegetation and maintain drainage is a factor.
 - In applications where it is necessary to distribute concentrated loads over a wide area.
- How
1. Design parameters should be reviewed and approved by a qualified engineer or CPESC (earth retention applications must be reviewed and approved by engineer).
 2. Specific materials and construction will vary according to project specifications.
 3. Infill material should be suitable for the hydraulic conditions. Consult designer specifications.
 4. Geoweb sections must be anchored as necessary using stakes, tendons, and/or restraint pins as required by designer.
 5. Install non-woven geotextile material along all areas with ground contact, with ends buried in trenches.
 6. Refer to product vendor for additional guidelines for specific site applications.



CELLULAR CONFINEMENT SYSTEM SPECIFICATIONS

E17

- Maintenance
- Confinement system should be checked periodically after installation for settling at base or indications of lateral movement. Individual cells may need additional fill due to consolidation of material.
 - Exposed areas should be stabilized with vegetation as soon as work is completed.
 - Slopes should be inspected after each rain event and at least monthly during first year of establishment to identify and address soil erosion problems as they occur.
- Limitations
- More expensive than other stabilization practices, which limits their use to necessary areas.
 - Seed germination may be delayed due to a lowering of soil temperature.
 - Engineer/Contractor required for proper installation.



**GRAND VALLEY
STATE UNIVERSITY.**

PLASTIC SHEETING

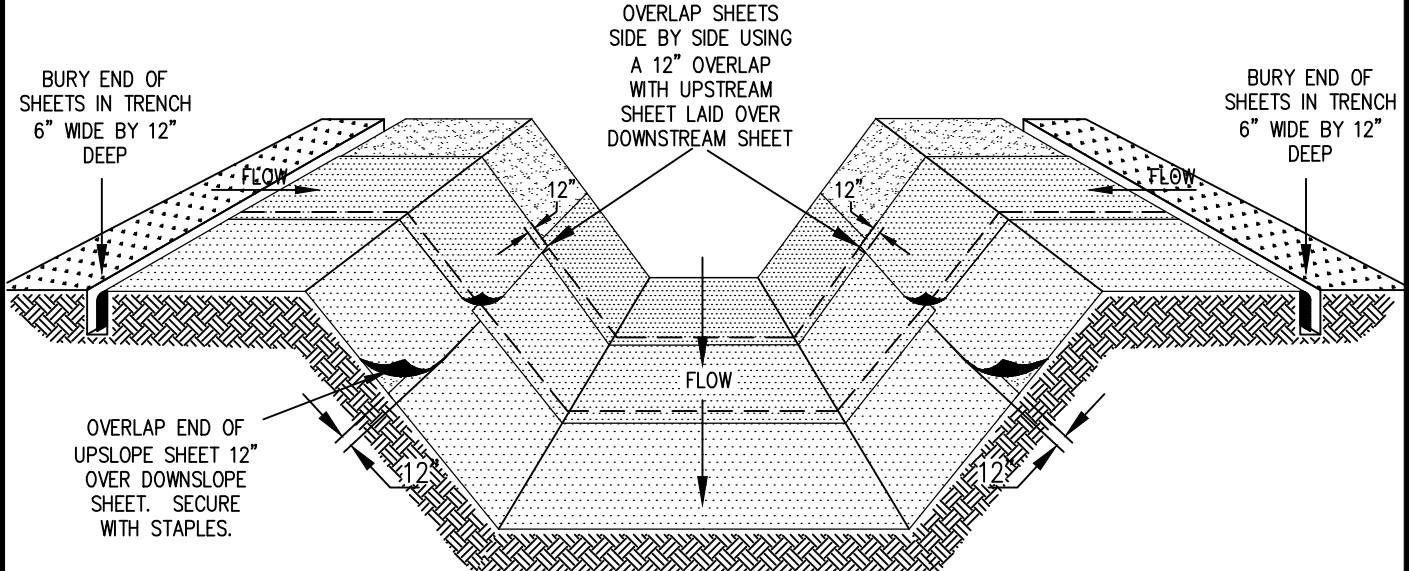

NOTE: WHEN SHEETS ARE USED IN FLOWING DITCH, SHEET ENDS SHOULD NOT OVERLAP PARALLEL TO FLOW DIRECTION IN DITCH CENTER

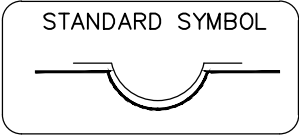

PLASTIC SHEETING SPECIFICATIONS

- When
- When unstable areas are subject to erosive surface flows or severe wind.
- Why
- Protects unstable areas and slopes against erosion from rain or wind.
- Where
- Use for immediate protection on exposed slopes, new ditch bottoms, and other areas subject to surface water runoff and erosion.
 - Use to create a liner in temporary channels.
 - Used to create temporary cover to prevent erosion of stockpiled materials.
- How
1. Prepare subgrade to proper grade and compaction requirements.
 2. Remove ruts, roots, soil clods, or other debris from surface subject to plastic sheeting installation.
 3. Consult with erosion control material supplier to select plastic sheeting based on slope gradient, expected surface run-off, and protection term necessary. Sheeting should be at least 6 mils thick.
 4. Position plastic sheets as close as possible to intended use location and unroll perpendicular to the flow path of the channel.
 5. Install sheets down-stream first, progressing up-stream as if laying shingles. Do not lay sheets in the down-stream direction as this will allow water to seep underneath sheets and cause erosion. For the same reason, the sheets on the side slopes of the channel should be laid with the up-slope sheets placed over the down-slope sheet edge. Sheets should not overlap within the channel bottom.
 6. Overlap sheet edges by a minimum of 12" and sheet ends by a minimum of 12".
 7. Install up-slope sheet edge in a trench 6" wide X 12" deep.
 8. Secure sheet with staples or pegs of size and length suited to soil conditions immediately after plastic sheeting installation.





PLASTIC SHEETING SPECIFICATIONS

- Maintenance
- Check after a rain event to ensure the sheets are still in place.
 - Keep eroded soil, vehicular and pedestrian traffic, and concentrated runoff away from the sheeted area.
- Limitations
- For temporary use only.
 - Will fail if water flows beneath the plastic sheeting.
 - Plastic is prone to damage by wind or strong currents.
 - Will deteriorate over time.



E19

TEMPORARY DRAINAGEWAY/STREAM CROSSING

TEMPORARY CROSSING – CULVERT

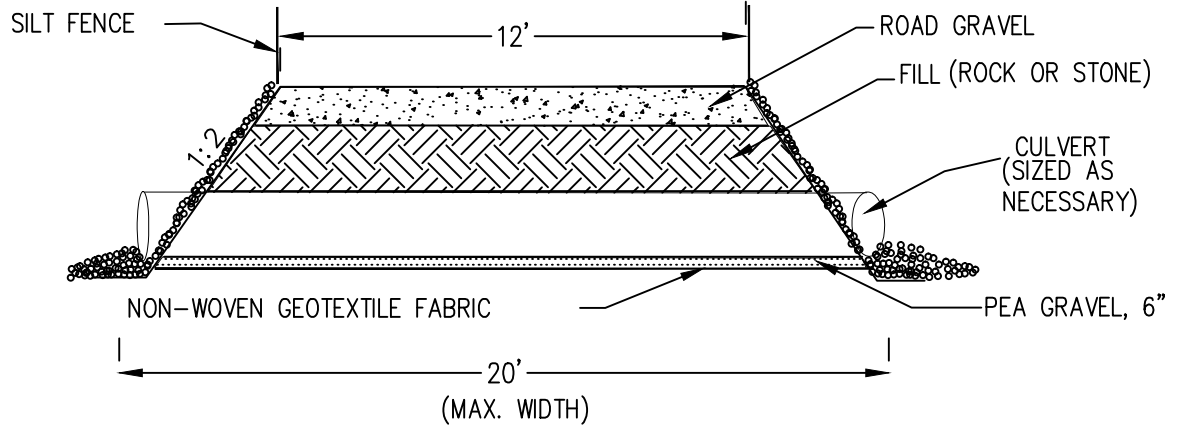

TEMPORARY CROSSING – PLAN VIEW

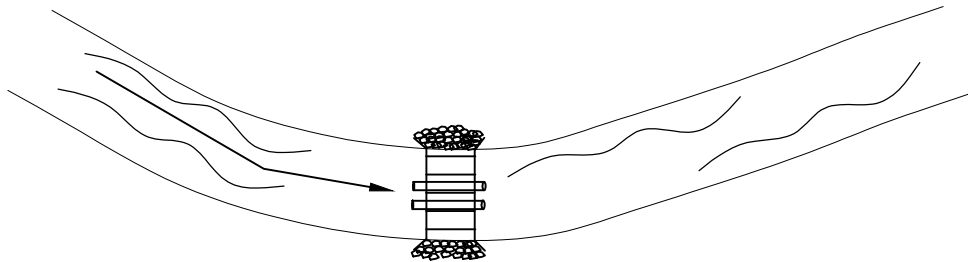

TEMPORARY CROSSING – BRIDGE

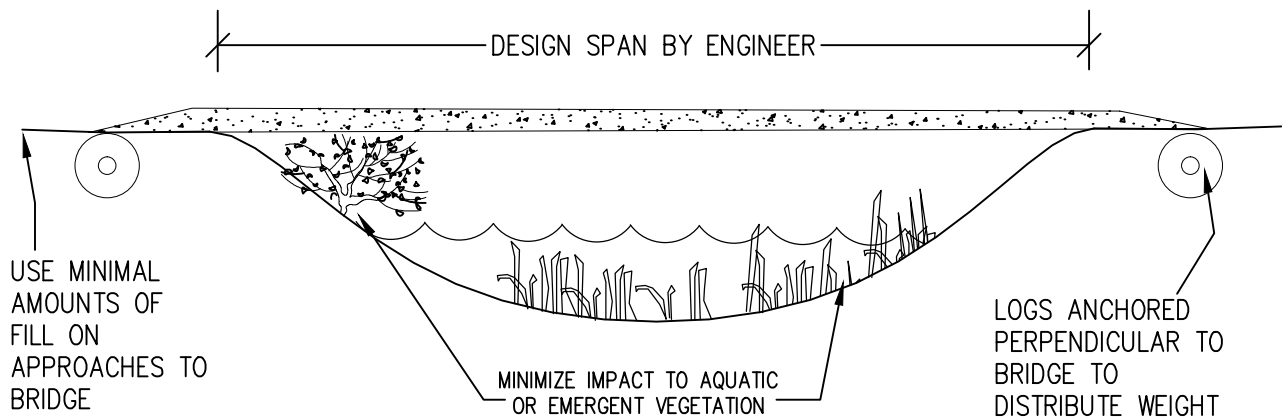

STANDARD SYMBOL

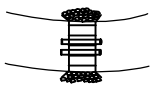

GRAND VALLEY
STATE UNIVERSITY

TEMPORARY DRAINAGEWAY/STREAM CROSSING SPECIFICATIONS

E19

- When
- When construction equipment requires temporary stream crossing.
- Why
- To minimize the erosion/sedimentation impact on soils and vegetation at watercourse crossing area from equipment traffic.
- Where
- On construction sites where stream/drainageway crossings are required.
- How
1. Review site to identify crossing locations involving minimal environmental impact.
 2. Verify necessary permits for crossing construction have been obtained prior to initiating crossing construction.
 3. Install sediment trap downstream prior to construction.
 4. Place pea gravel bed on non-woven geotextile fabric for culvert bedding. Install culvert to match existing drain bottom elevation.
 5. Place approximately 1'–2' of clean rock or stone over culvert.
 6. Place 1' of crushed gravel for temporary stream crossing surface.
 7. Place silt fence along top of road edge to minimize sedimentation at crossing.
 8. Upon completion of construction, temporary stream crossing shall be removed and all slopes stabilized.

Temporary Stream Crossing

1. Temporary Stream Crossing – Bridge – preferred type; timber deck with no abutments.
2. For use only in stream crossing where bank is stable.
3. Structure to be designed by project engineer.
4. On both banks, anchor logs perpendicular to bridge to help in weight distribution.



**GRAND VALLEY
STATE UNIVERSITY.**



TEMPORARY DRAINAGEWAY/STREAM CROSSING SPECIFICATIONS

How
(cont.)

5. Use timber, concrete, or metal as bridge surface.
6. Anchor bridge surface to logs, width of bridge should be kept at a minimum.

Maintenance

- Silt fences should be checked every day, with repairs done when necessary.
- Inspect weekly and after each rain event.
- Empty sediment trap when half full, and conduct repairs to trap when needed.
- Repair riprap at culvert end sections as necessary.

Limitations

- Construction should be at or near natural elevation to prevent upstream flooding.
- Temporary culverts need regular maintenance, if they become clogged, erosion of the slopes could occur.



**GRAND VALLEY
STATE UNIVERSITY.**

E20

TEMPORARY BYPASS CHANNEL

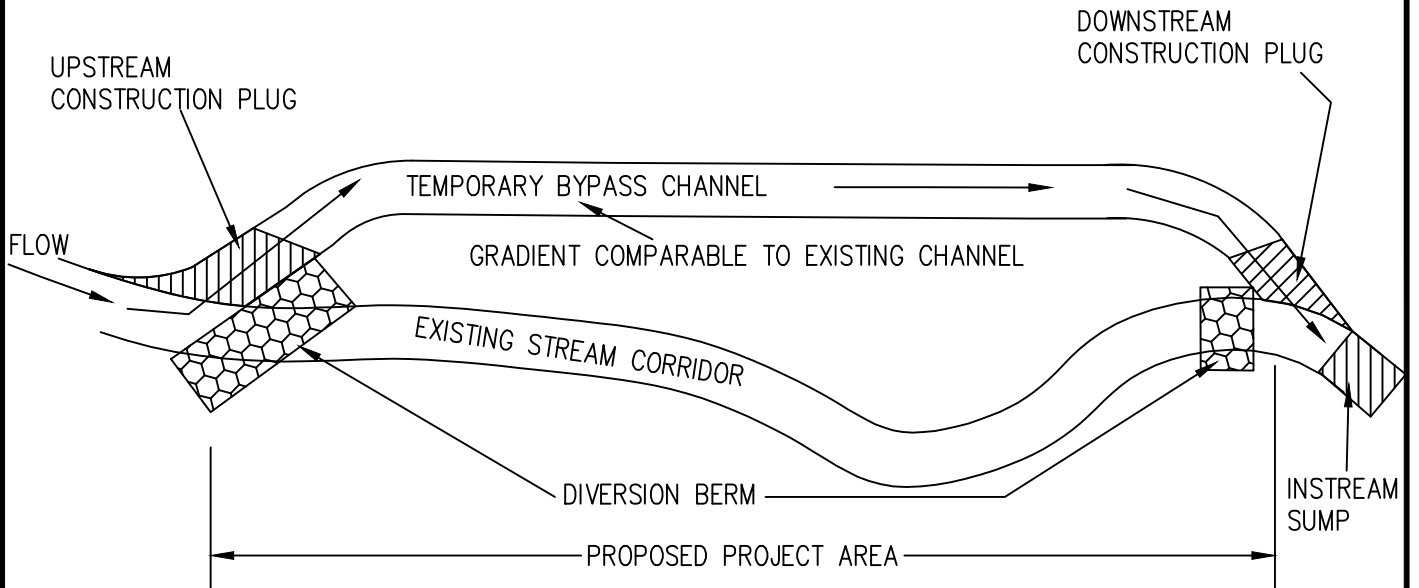

TEMPORARY BYPASS CHANNEL CONCEPT

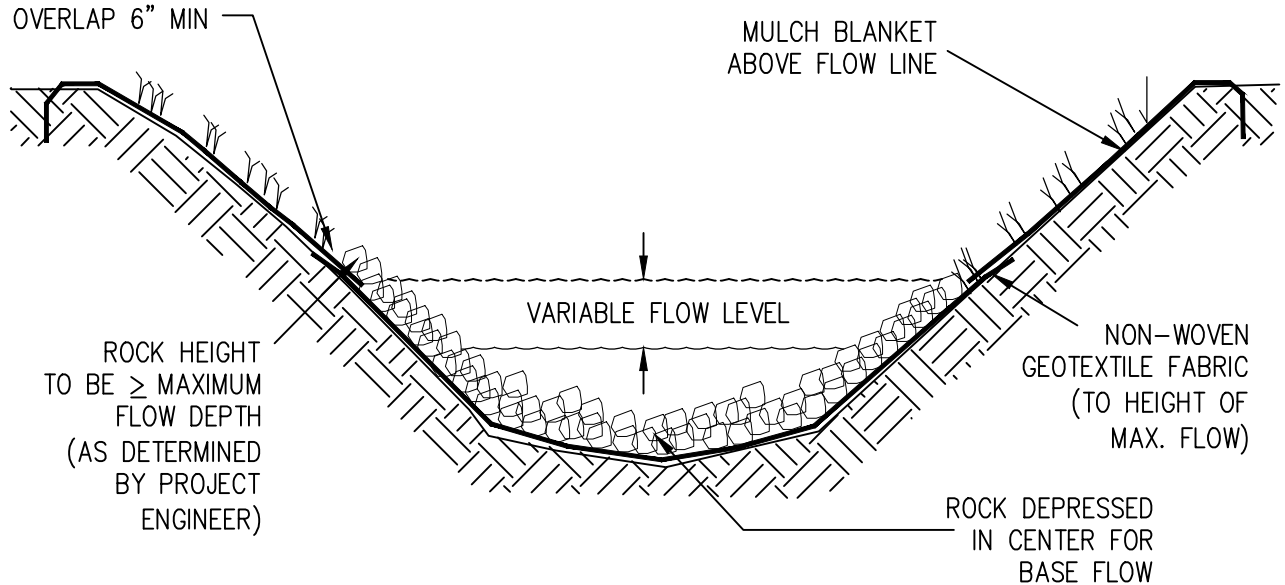

TYPICAL BYPASS CHANNEL CROSS SECTION

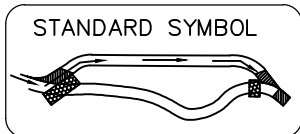

TEMPORARY BYPASS CHANNEL SPECIFICATIONS

E20

When	<ul style="list-style-type: none">• When stream flow prevents access to a portion of the existing channel requiring construction, stabilization or modification.
Why	<ul style="list-style-type: none">• To minimize downstream sedimentation resulting from a stream construction project.
Where	<ul style="list-style-type: none">• Within existing stream corridors when stream flow cannot be interrupted.
How	<ol style="list-style-type: none">1. Temporary bypass channels should be designed by an engineer or CPESC.2. Channel should be located with consideration of topography to minimize environmental disturbance.3. Channel width should be minimized and established based on expected flow rates during construction duration.4. Prior to excavation construct in-stream sediment sump below temporary channel outlet.5. Excavation should be conducted during periods of low flow, leaving plugs at each end of excavated channel until entire channel is graded and stabilized.6. Use non-woven geotextile fabric and stone to stabilize channel to high water level.7. Following channel stabilization remove earthen plugs, beginning with downstream plug first.8. Place diversion berm on non-woven geotextile fabric in upstream end of existing channel to direct flow into temporary bypass. Following drainage of existing stream corridor, place downstream diversion berm on non-woven geotextile fabric to prevent stream flow from entering desired work channel.
Maintenance	<ul style="list-style-type: none">• Inspect bypass channel, diversion berm and stream channel routinely and after each rain event.



**GRAND VALLEY
STATE UNIVERSITY.**



TEMPORARY BYPASS CHANNEL SPECIFICATIONS

Maintenance
(cont.)

- Check downstream sediment sump for accumulation. Clean out when 1/2 full.
- Place sediment on an upland site and stabilize.
- Remove diversion berms upon construction completion, restore and stabilize temporary channel and sediment sump area.

Limitations

- Difficulties increase in proportion to size of stream.
- Requires possession of or easement through adjacent riparian land.
- Costly to implement.



**GRAND VALLEY
STATE UNIVERSITY.**

LIVE STAKING

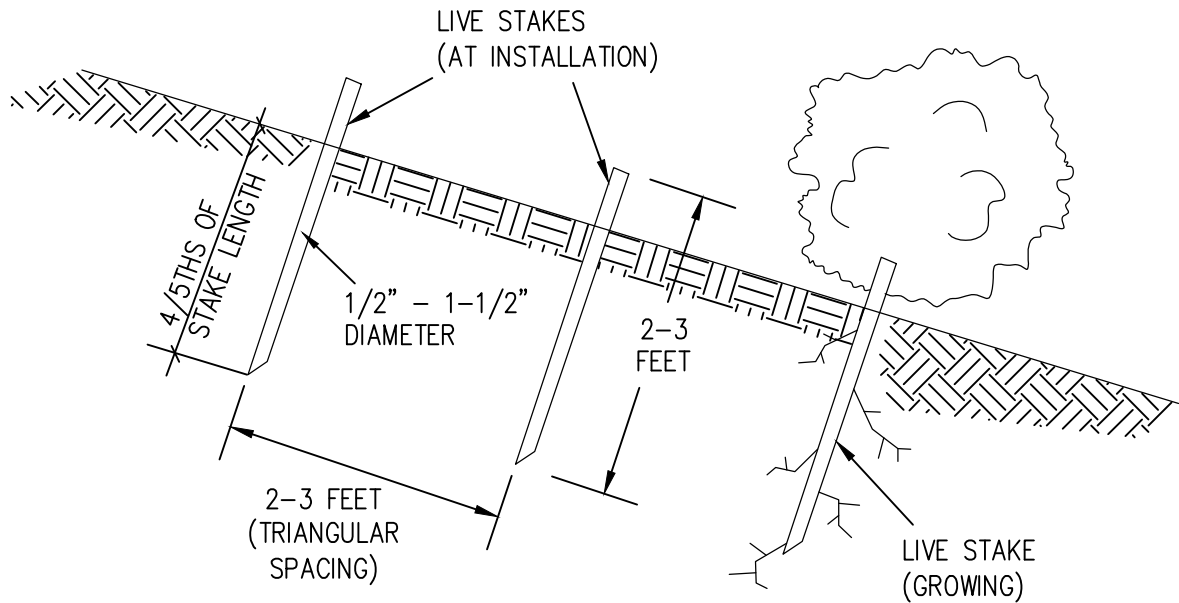

MICHIGAN SPECIES SUITABLE FOR LIVE STAKING BY SOIL TYPE

SAND

<i>Acer negundo</i>	Box Elder	<i>Robinia pseudacacia</i>	Black Locust
<i>Cornus ammomum</i>	Silky Dogwood	<i>Rubus strigosus</i>	Red Raspberry
<i>Cornus racemosa</i>	Gray Dogwood	<i>Salix exigua</i>	Sandbar Willow
<i>Cornus rugosa</i>	Round-leaf Dogwood	<i>Salix spp.</i>	Willow spp.
<i>Cornus sericea</i>	Red Osier Dogwood	<i>Sambucus canadensis</i>	American Elderberry
<i>Physocarpus opulifolius</i>	Common Ninebark	<i>Spirea alba</i>	Meadowsweet
<i>Populus deltoides</i>	Eastern Cottonwood	<i>Viburnum lentago</i>	Nannyberry Viburnum

LOAM

<i>Acer negundo</i>	Box Elder	<i>Robinia pseudacacia</i>	Black Locust
<i>Cornus ammomum</i>	Silky Dogwood	<i>Rubus strigosus</i>	Red Raspberry
<i>Cornus racemosa</i>	Gray Dogwood	<i>Salix exigua</i>	Sandbar Willow
<i>Cornus sericea</i>	Red Osier Dogwood	<i>Salix spp.</i>	Willow spp.
<i>Populus deltoides</i>	Eastern Cottonwood	<i>Viburnum lentago</i>	Nannyberry Viburnum
<i>Populus tremuloides</i>	Quaking Aspen		

CLAY

<i>Acer negundo</i>	Box Elder	<i>Rubus strigosus</i>	Red Raspberry
<i>Cornus racemosa</i>	Gray Dogwood	<i>Viburnum dentatum</i>	Arrowwood Viburnum
<i>Cornus sericea</i>	Red Osier Dogwood	<i>Viburnum lentago</i>	Nannyberry Viburnum
<i>Populus deltoides</i>	Eastern Cottonwood		

MUCK

<i>Cornus ammomum</i>	Silky Dogwood	<i>Sambucus canadensis</i>	American Elderberry
<i>Cornus sericea</i>	Red Osier Dogwood	<i>Spirea alba</i>	Meadowsweet
<i>Physocarpus opulifolius</i>	Common Ninebark		

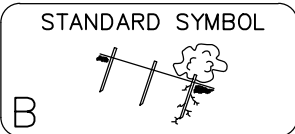

NOTE: IRRIGATION OF LIVE-STAKED AREAS IS RECOMMENDED



LIVE STAKING SPECIFICATIONS

E21

When

- When seeps and wetland soils are subject to failure and shallow slumping.
- When vegetative establishment can aid in the reduction of soil erosion and sedimentation.

Why

- Quick, inexpensive, simple method to inhibit soil movement, preserve natural drainage, and to allow native vegetation to provide slope stabilization.

Where

- In areas requiring protection of slopes against surface erosion and shallow mass wasting.
- On cut and fill slopes or other earth embankments, including dunes, shorelines, and streambanks requiring stabilization.
- In wetland buffers or reservoir drawdown areas where plants may be submerged for extended periods or subject to varying water levels.
- In areas requiring stabilization but with limited access for equipment or when relatively little site disturbance during installation is preferred.
- When construction time is limited and an inexpensive method is necessary.
- May be used for pegging down surface erosion control materials.
- Enhances conditions for natural colonization of plant species from adjacent areas. Creates habitat for existing animal species.
- Can be used to stabilize intervening areas between other soil bioengineering techniques, such as wattles (see sheet ES41).

How

1. Identify local source of native plant species suitable for collection, based on consideration of purpose, climate, soil type, and moisture regime.
2. Obtain approval for material collection.



**GRAND VALLEY
STATE UNIVERSITY.**



LIVE STAKING SPECIFICATIONS

How
(cont.)

3. Collect and prepare 1/2" – 1-1/2" diameter cuttings 2–3' in length from native vegetative community utilizing care to prevent overharvesting or depletion of native site vegetation.
4. Collect material removing side branches while leaving bark intact, cut top square with bottom angled for easy installation.
5. Install materials same day as collection.
6. Tamp live stakes into ground using a dead blow hammer. On dense or firm soil, an iron bar can be used to create a pilot hole. Care should be taken not to split stake. Split stakes should be removed and replaced.
7. Install live stakes 2'–3' apart with buds facing upward using triangular spacing at a density of 2–4 stakes/sq.yd.
8. Install four fifths of live stake in ground and pack soil firmly around stake after installation.
9. Mulch between stakes.

Maintenance

- All installations should be inspected regularly and provisions made for prompt repair if needed. Small failures can generally be repaired easily but quickly lead to larger failures if unattended.
- Periodic pruning and replanting may be required to maintain healthy and vigorous vegetation

Limitations

- Not intended for areas proposed to be mowed.
- Supplemental irrigation may be necessary to establish vegetation via live staking on dry, sandy soils.
- Live staking may require irrigation, especially in dry locations.



Appendix 5

ES31

CHECK DAM

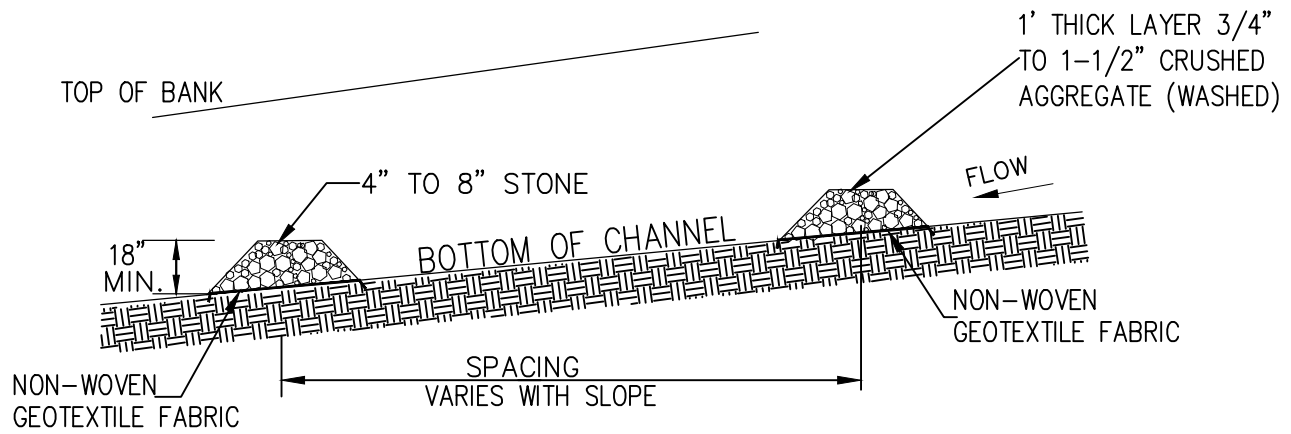

PROFILE

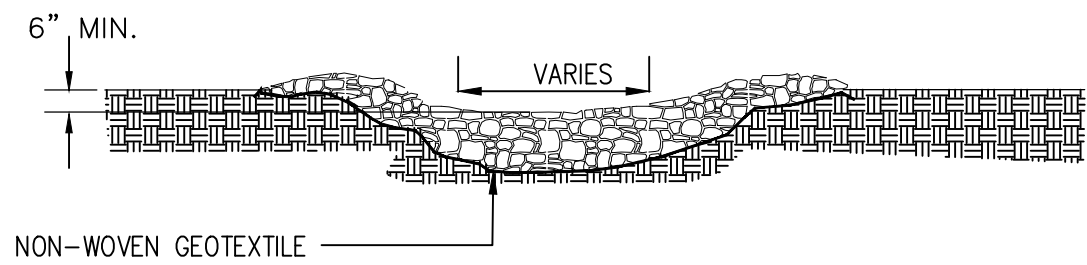

CROSS SECTION

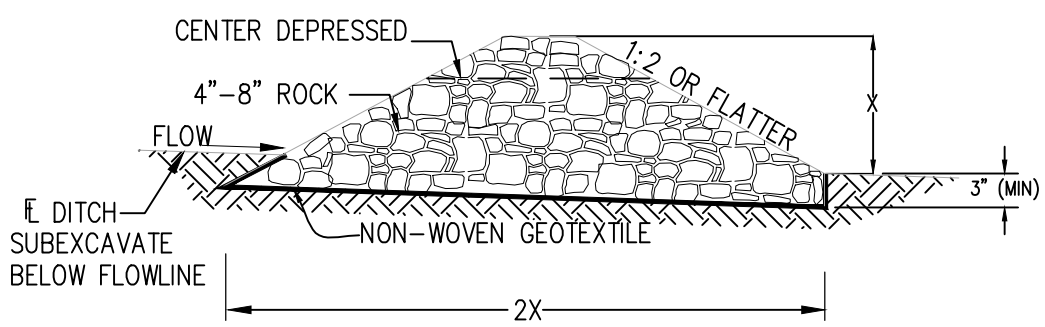

PROFILE

NOTE: BASE WIDTH SHOULD BE AT LEAST 2X THE HEIGHT

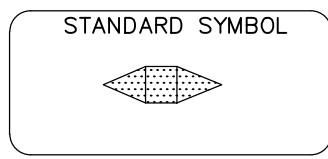

CHECK DAM SPECIFICATIONS

- When**
- To reduce surface flow velocities.
- Why**
- To minimize erosion in flow corridors.
- Where**
- Within constructed flow corridors to reduce velocity until permanent stabilization is achieved.
 - Within existing flow corridors to address or prevent velocity-caused erosion.
- How**
1. The check dam shall be constructed of rock only.
 2. The rock shall be placed on non-woven geotextile fabric.
 3. Remove woody vegetation prior to placing non-woven geotextile fabric.
 4. Non-woven geotextile fabric shall be inset a minimum of 3" below adjacent grades.
 5. The check dam shall be constructed of 4"–8" stone. The stone shall be placed to completely cover the width of the flow corridor and shall be keyed into adjacent banks.
 6. The middle of the check dam shall be lower than the outer edges, such that no flow goes around the structure.
 7. The up-stream side of the check dam can be lined with smaller crushed aggregate to improve efficiency.
 8. Slopes of check dam should be 1:2 or flatter.
- Maintenance**
- Check dams should be inspected after each runoff event.
 - Clogged stone should be periodically cleaned.
 - Needed repairs should be initiated immediately after inspection.
 - Accumulated upflow sediment should be periodically removed.
 - If check dam is intended as temporary structure, remove after stabilization is achieved.
- Limitations**
- Use only in small open channels which drain 10 acres or less.
 - Not to be used in live streams.

ES32

STONE FILTER BERM

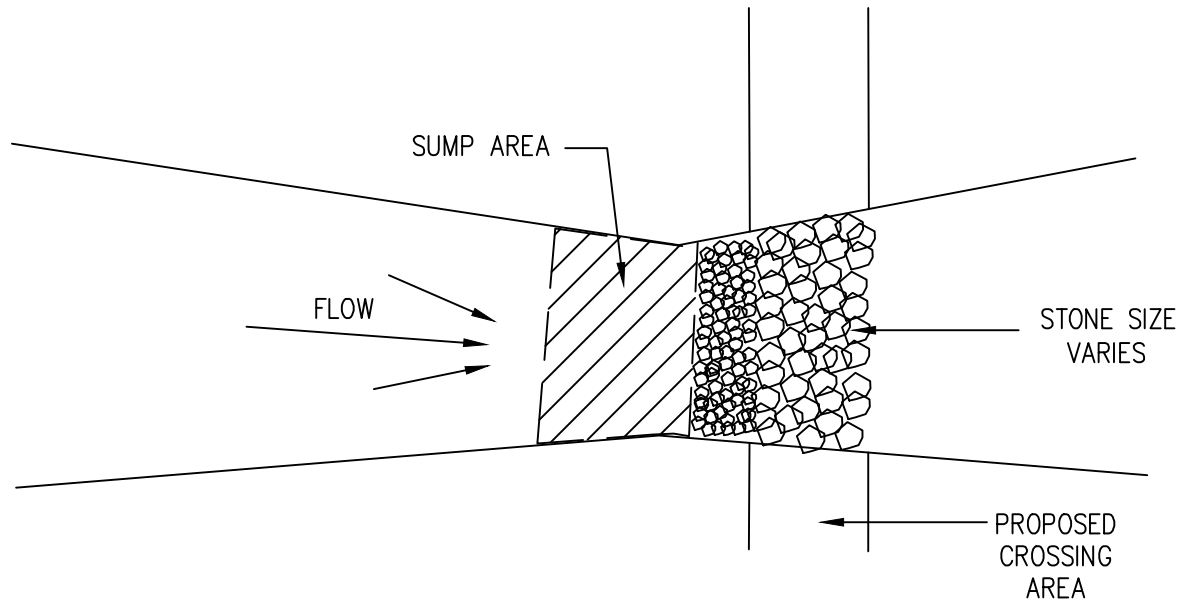

DRAINAGEWAY FORD WITH UPSTREAM SUMP

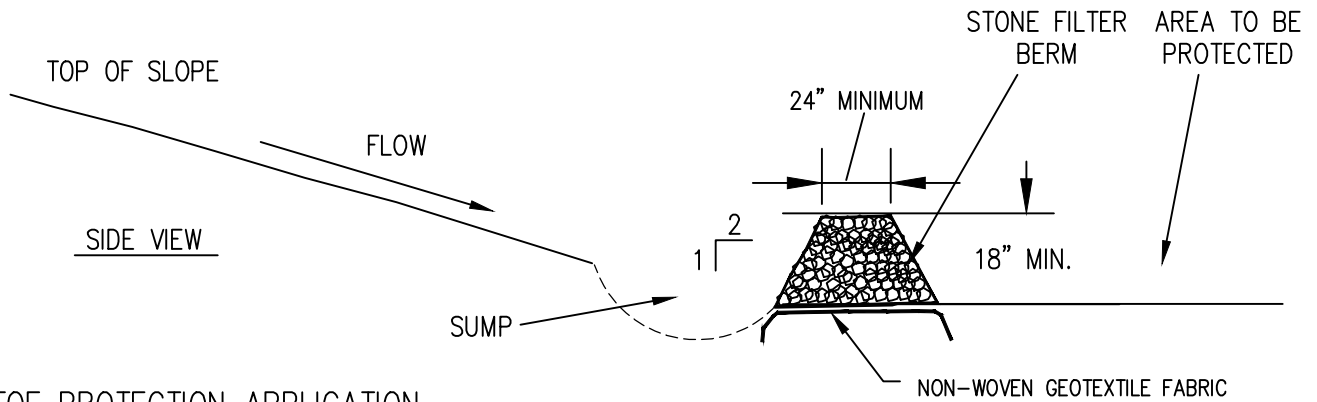

TOE PROTECTION APPLICATION

STANDARD SYMBOL



**GRAND VALLEY
STATE UNIVERSITY.**

STONE FILTER BERM SPECIFICATIONS

When	<ul style="list-style-type: none">• When sediment laden runoff from disturbed areas, specifically slopes or drainageways, threaten waterbodies, sensitive areas, or adjacent properties.
Why	<ul style="list-style-type: none">• To filter out sediment in surface flows and slow velocity to release water as sheet flow.• To allow crossing of drainageways without causing rutting or sedimentation.
Where	<ul style="list-style-type: none">• Use primarily in areas where sheet or rill flow occurs.• For use as a temporary measure to cross drainageways, along the site perimeter, around temporary spoil areas, and along streams or constructed channels.
How	<ol style="list-style-type: none">1. Place along a level contour.2. Use 3/4" to 3" sized rock in areas of sheet flow. Use 3" to 5" rock in areas with concentrated flow; fill interstices with smaller stone.3. Sheet flow from filter berm should be released into stabilized area.4. Create a sump area on the upslope side of the berm where runoff can pond and sediment can settle. Construct large enough to support runoff volume.5. Drainage area should not exceed 5 acres.6. Allow ample room in construction of the filter berm to allow equipment access for sediment removal and maintenance of the berm.
Maintenance	<ul style="list-style-type: none">• Inspect monthly and after each rainfall.• If berm is damaged, reshape and replace dislodged rock.• Remove sediment when depth reaches 1/3 of sump depth.
Limitations	<ul style="list-style-type: none">• Not for use in concentrated, continuous flows.• Not for use in areas intended for mowing.



FILTER ROLLS

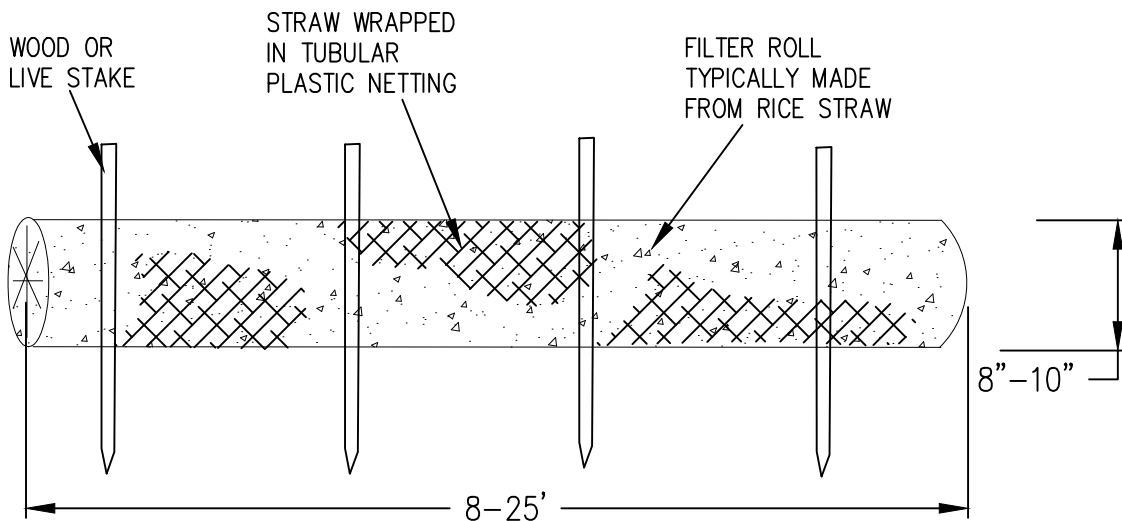
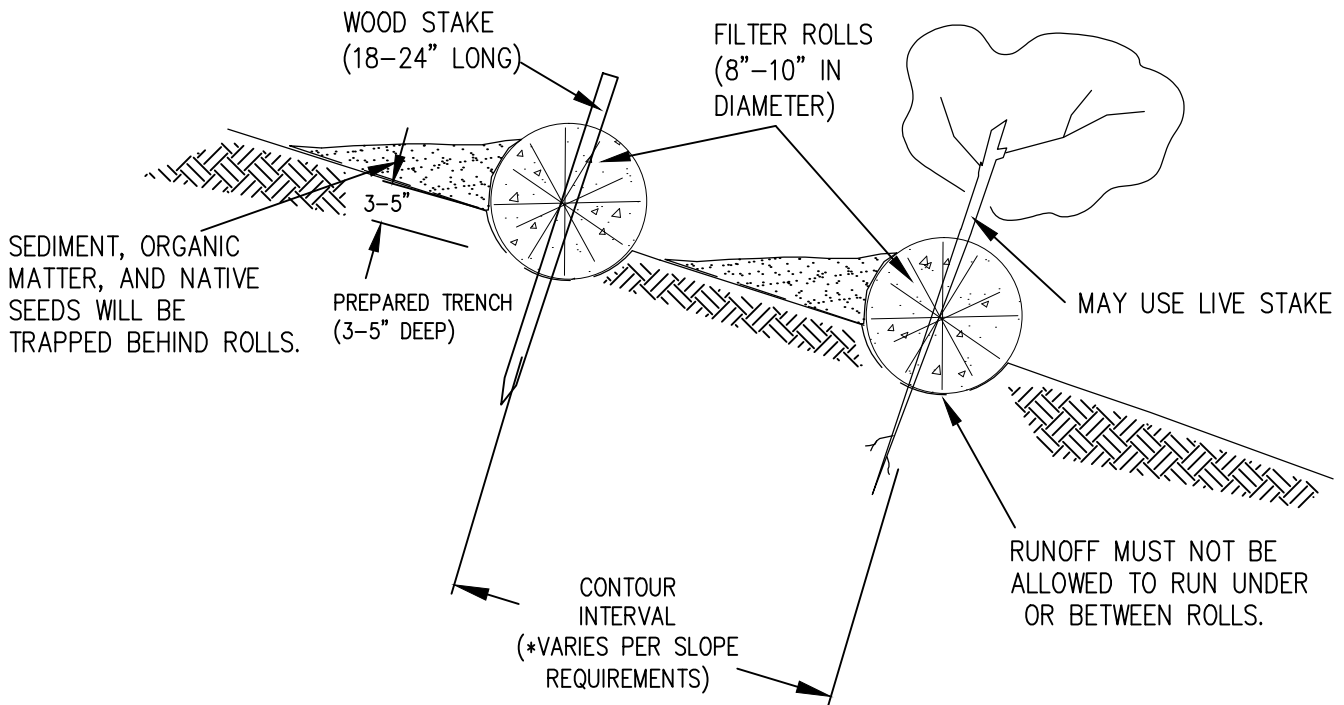

* SPACING INTERVAL

SLOPE	1:1	1:2	1:3	1:4	1:6
CONTOUR INTERVAL	3'	4'	5'	6'	8'

ADAPTED FROM NRCS, SOMERSET, NJ

STANDARD SYMBOL

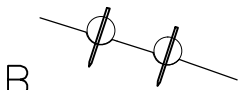

B

FILTER ROLL SPECIFICATIONS

- When
- When a reduction in flow velocity is necessary and sheet flow is desirable.
 - When vegetation establishment can prevent or reduce gully formation and erosion on slopes.
- Why
- To inhibit soil movement and gully formation.
- Where
- In areas requiring immediate protection of slopes against surface erosion and gully formation.
 - In areas requiring stabilization but with limited access for equipment or when relatively little site disturbance during installation is preferred.
 - On cut and fill slopes or other earth embankments, including dunes, shorelines, and streambanks requiring stabilization.
 - In wetland buffers or reservoir drawdown areas where plants may be submerged for extended periods.
- How
1. Review slope steepness and soil type to determine necessary contour interval, trench length, and material needs. (Consult table for appropriate spacing interval.)
 2. Lay out contour interval on slope. Roll should not cross contours.
 3. Starting at slope base, hand dig trench 3–5” deep along level contour, wide enough to accommodate the filter roll diameter.
 4. Place filter roll in prepared trench.
 5. Drive 18 or 24” stakes directly into filter roll at 4 foot on center, along its entire length. Live stakes may be used in place of wood stakes. (If live stakes used, see sheet E21 Live Staking)
 6. The ends of adjacent filter roll should be abutted to each other snugly. Runoff must not be allowed to run under or around roll.



FILTER ROLL SPECIFICATIONS

How (cont.)

7. Move upslope the appropriate contour interval distance, repeat preceding steps. Repeat process until reaching top of slope.
8. Mulch between rolls.
9. If used as a temporary control, straw from roll may be used as mulch when control measure is complete.

Maintenance

- All installations should be inspected regularly and provisions made for prompt repair if needed. Small failures can generally be repaired easily, but quickly lead to larger failures if unattended.
- If live staking is used, periodic pruning and replanting may be required to maintain healthy and vigorous growth.

Limitations

- Not intended for perennial flow corridors.
- Will fail if runoff undercuts roll.
- Do not use in areas to be mowed.



ES34

SAND FENCE

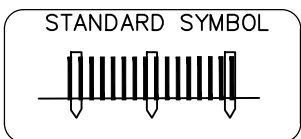
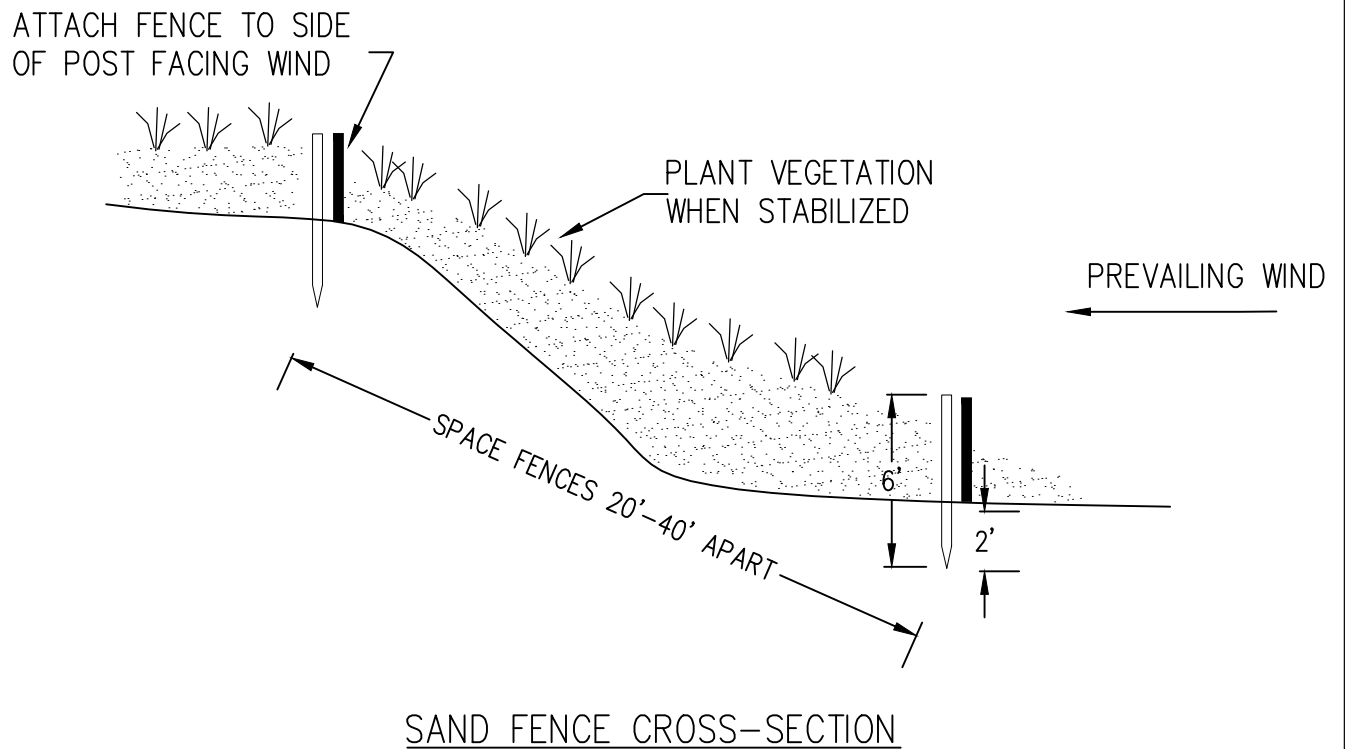
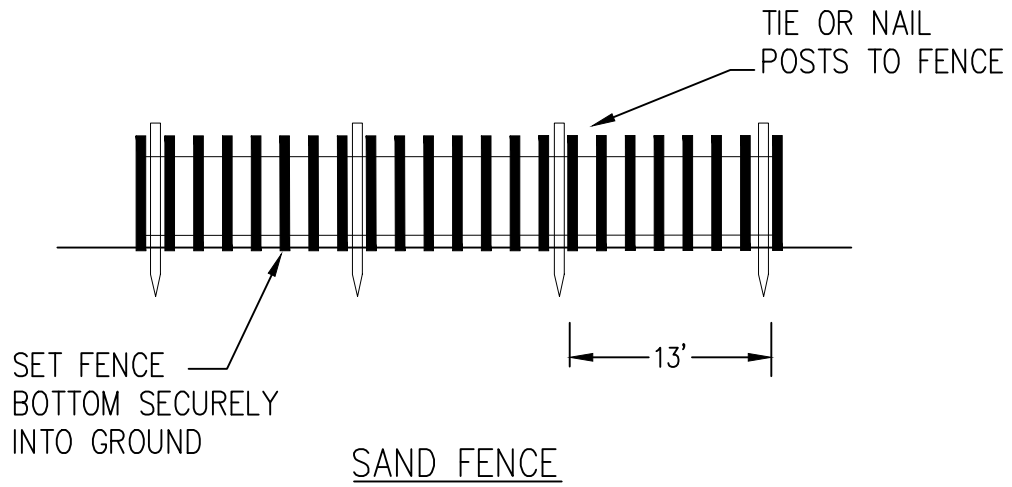

SAND FENCE SPECIFICATIONS

When	<ul style="list-style-type: none">• In areas susceptible to wind erosion, particularly where the ground has not yet been stabilized through other means.
Why	<ul style="list-style-type: none">• To trap blowing sand, reducing erosion.• To assist in stabilizing or re-building a slope.
Where	<ul style="list-style-type: none">• Use along coastal dunes, across open areas subject to frequent wind, along roads, job sites, and adjacent to agricultural fields.
How	<ol style="list-style-type: none">1. Sand fences are generally made up of wooden slats spaced approximately 1.5 inches apart or consist of plastic web material.2. Place sand fence perpendicular to prevailing wind direction.3. Anchor fence with sturdy posts at least 6 feet long. Drive posts into the ground approximately 2 feet.4. Space the posts approximately 13 feet apart. Spacing may be altered to ensure posts are placed at low points.5. Securely attach sand fence to posts on windward side by tying or nailing fence material to each post.6. Be sure the bottom of the fence is set securely into the ground.7. After the row of fence has accumulated sand up to $\frac{2}{3}$ its height, another row of fence will need to be erected.8. Plant vegetation to stabilize the sand when the building process slows significantly.
Maintenance	<ul style="list-style-type: none">• Maintain sand fences until area stabilized by vegetation. At that time the fences may be removed.
Limitations	<ul style="list-style-type: none">• Removal of fences may disturb established vegetation in stabilized areas unless adequate equipment access routes are planned.



DEWATERING

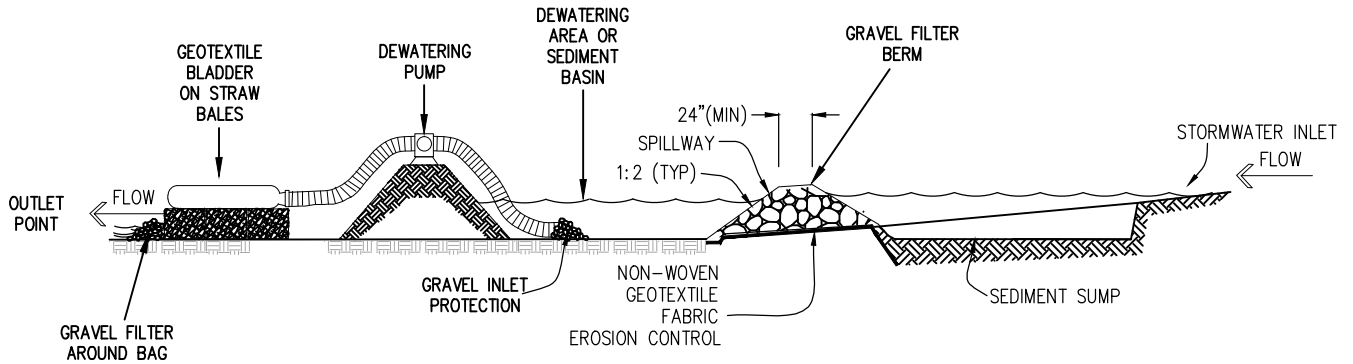

DEWATERING WITH OUTLET FILTER BAG

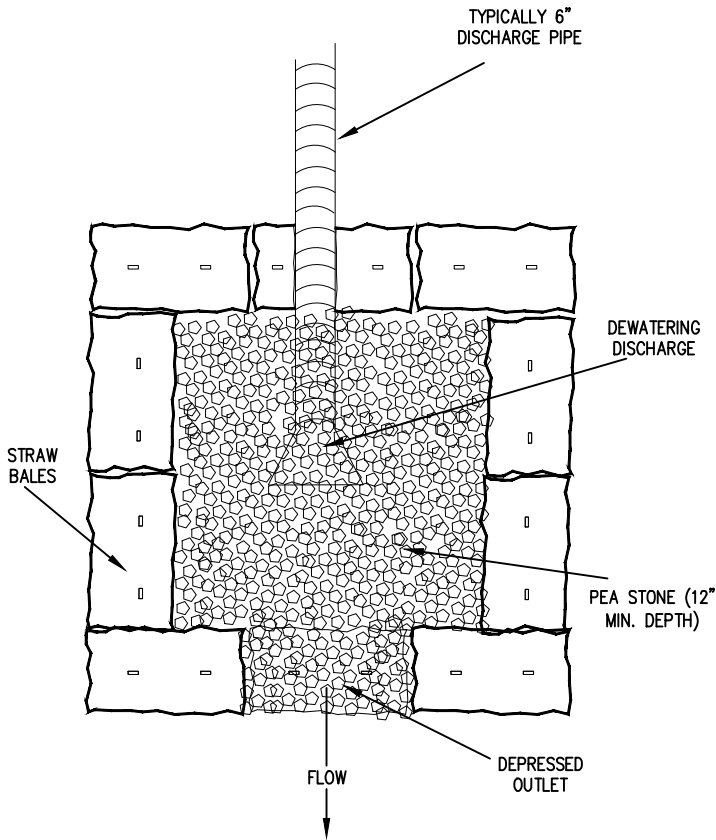

DEWATERING INTO STABILIZED OUTLET

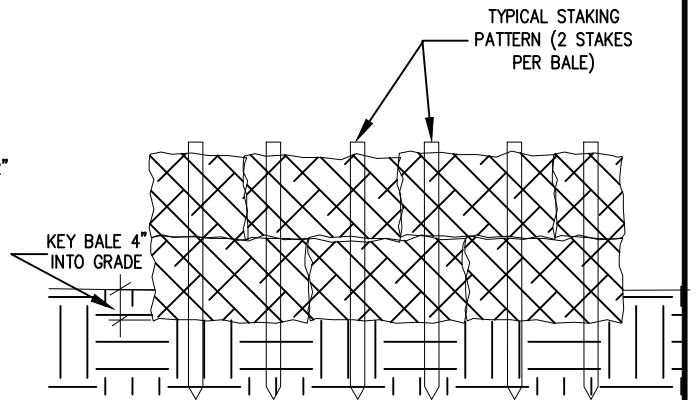

BALE STAKING DIAGRAM

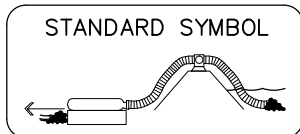

DEWATERING SPECIFICATIONS

- When
- When construction activities are limited by presence of water and dry work area is required.
 - When water prevents or limits construction or when accumulated construction area stormwater requires discharge.
- Why
- Removes ground or surface water to facilitate construction activities (Release must be filtered of sediment).
- Where
- Use in areas with high ground water tables or those without adequate drainage anytime dewatering may contain sediment.
- How
1. Dewatering system to be designed by engineer or CPESC.
 2. Obtain appropriate permits from local authorities for discharge into receiving waters.
 3. Dewatering system must be of sufficient size and capacity to maintain a dry condition without delays to construction operations.
 4. Dewatering must be conducted so that discharge water velocity doesn't cause scouring of receiving area.
 5. If sediment filtration is required, water should be filtered through a stone filter near dewatering pump inlet or released through a filter prior to discharge.
 6. Sediment accumulated as part of discharge filtering must be either spread and stabilized on-site or disposed of in a manner approved by the project manager.
 7. For stationary dewatering device, identify and structure dewatering area complete with appropriate filter.
 8. For portable dewatering device, identify suitable dewatering pump area and place filter bag on outlet pipe prior to discharge.
- Maintenance
- Maintain sediment controls and filters in good working order.
 - Inspect excavated areas daily for signs of contaminated water as evidenced by discoloration, oily sheen, or odors.
 - Inspect dewatering discharge points daily for signs of scour or erosive damage.
 - Repair any problems immediately.

DEWATERING SPECIFICATIONS

Limitations

- Does not provide filtration of contaminated stormwater flows.
- Discharge may result in erosion of receiving watercourse unless properly stabilized.
- Requires adequate sediment settling area prior to discharge point to be effective.



DIVERSION DIKE/BERM

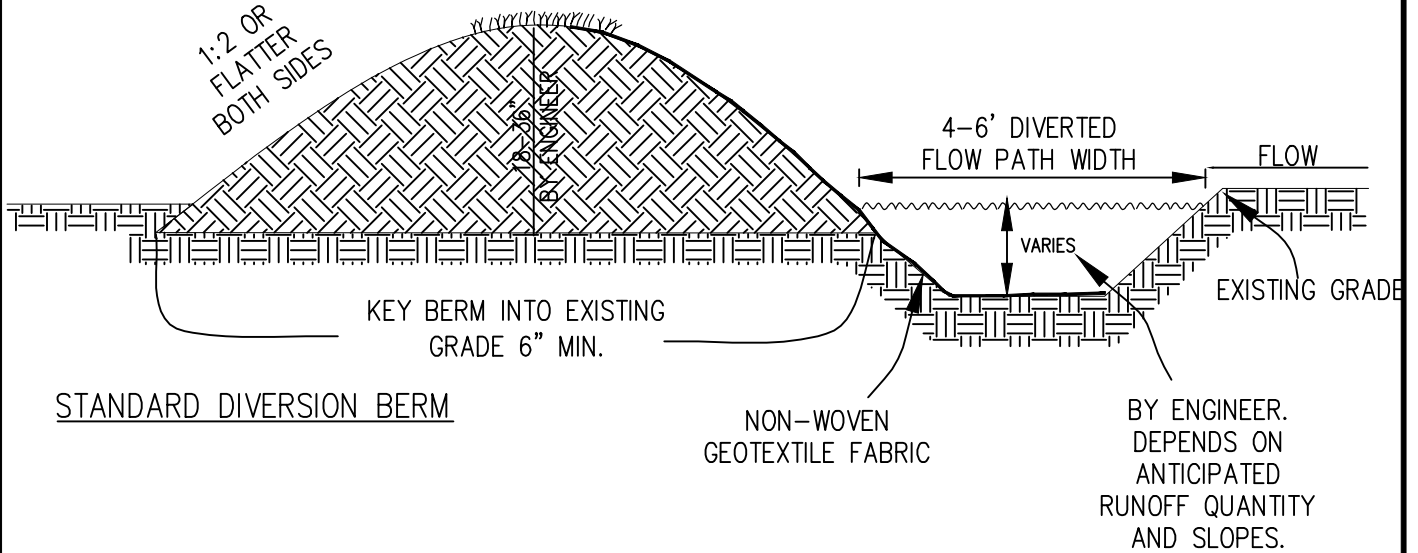

STANDARD DIVERSION BERM

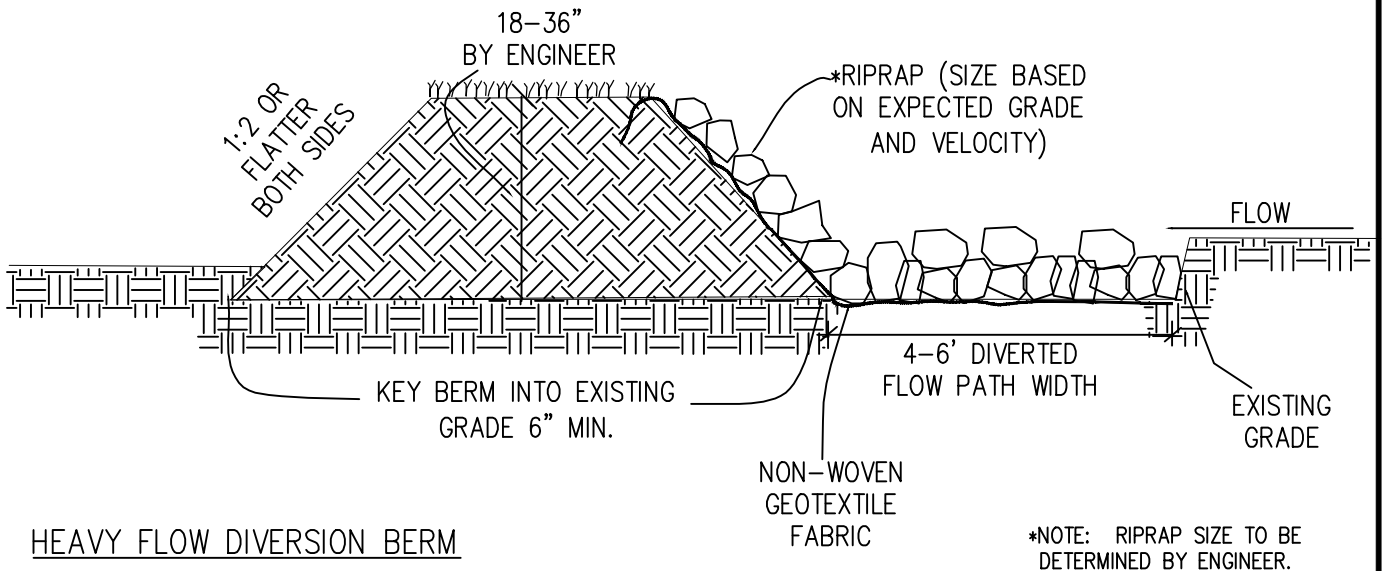

HEAVY FLOW DIVERSION BERM

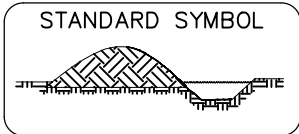

DIVERSION DIKE/BERM SPECIFICATIONS

ES36

- When
- When it is necessary to reroute surface sheet flow around, through, or from a construction area.
- Why
- To minimize potential for erosion and capture sediment-laden water.
- Where
- Above and below construction areas.
- How
1. Review site and site plans to determine unstable areas subject to erosive surface runoff velocities, areas in need of surface water diversion for construction completion, or areas where diversion of sediment-laden runoff needs to be directed to sediment basins.
 2. Care should be taken to select berm/dike locations to allow diverted runoff to be directed toward stabilized areas or outlet points.
 3. Berm/dike construction must consider the quantity of runoff to be diverted, expected velocity of diverted runoff, and the erodability of the soils on existing slopes and within the berm/dike.
 4. Unarmored berms/dikes should be constructed of relatively impermeable materials capable of withstanding expected runoff velocities.
 5. Toe of berm/dike should be keyed into existing grade a minimum of 6".
 6. Berm/dike material should be placed and compacted by earth moving equipment.
 7. Diversion berms/dikes should have side slopes 1:2 or flatter, 18" minimum heights, and 24" minimum top widths (actual structure to be sized by engineer).
 8. Stabilization of berm/dike should occur immediately following construction.
 9. Stabilization of temporary berms/dikes on slopes 1:2 or flatter can be stabilized by seed/mulch, on steeper slopes stabilization can be achieved by riprap or sod.



**GRAND VALLEY
STATE UNIVERSITY.**

DIVERSION DIKE/BERM SPECIFICATIONS

How
(cont.)

10. Dikes/berms utilized for long periods of time, or subject to frequent or high velocity discharges should be stabilized with riprap over toed-in non-woven geotextile fabric.
11. Construction equipment can be utilized to compact riprap into berm/dike.
12. Berm/dike should remain in place until construction is complete and all disturbed and vulnerable areas are permanently stabilized. May also be a permanent measure.

Maintenance

- Diversion berms should be inspected after each runoff event and repaired immediately.
- Receiving sediment basin (or area diverted to) should be monitored to insure sufficient capacity and function remains throughout period of flow diversion.
- Down-gradient outlet points should be inspected following each rain event to insure adverse impacts to outlet or adjacent properties is not occurring.
- The berm should be removed after all work in the adjacent area is completed and the vegetation stabilized, unless it is to become part of the permanent stormwater management system.

Limitations

- Earth dike berms must be stabilized immediately and not used until stabilized.
- Dikes should not be constructed of soils which may be easily eroded or will fail if saturated.
- Earth dikes may become barriers to construction equipment.
- Permanent berms may inhibit mowing/maintenance unless consideration for same is included in design.



DIVERSION DITCH

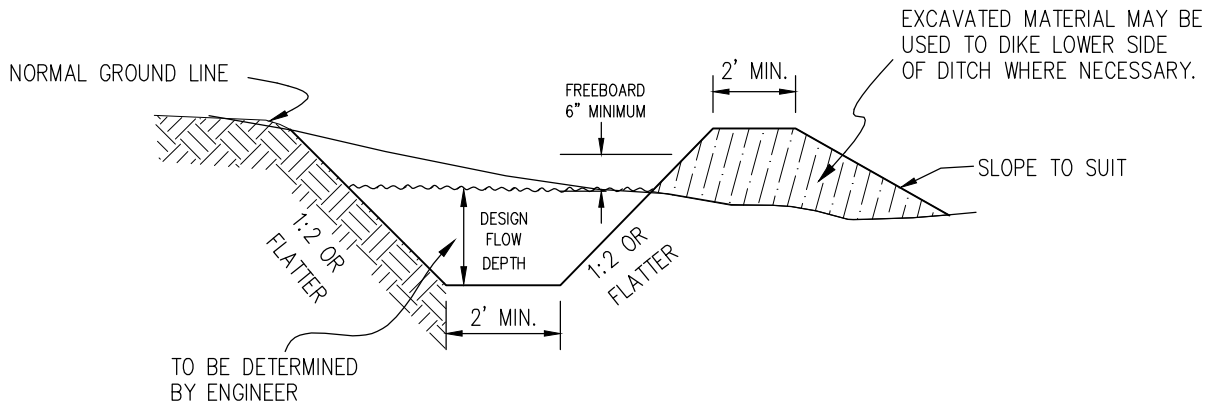

CUT SECTION FOR DITCHES

NOTES:

- ALL STRUCTURAL BEST MANAGEMENT PRACTICES TO BE DESIGNED BY A REGISTERED ENGINEER OR LANDSCAPE ARCHITECT.
- ALL DIVERSIONS SHOULD BE FLAT BOTTOM. AVOID "V" PROFILES.
- MAY USE VEGETATED CHANNELS (SEE E11).

STANDARD SYMBOL



**GRAND VALLEY
STATE UNIVERSITY.**

DIVERSION DITCH SPECIFICATIONS

- When
- Temporarily diverts runoff around disturbed construction areas, highly erodible soils and other sensitive areas such as steep slopes.
- Why
- To reduce erosion and sedimentation and route surface flows away from vulnerable areas, to divert flows to proposed sediment basins, and to prevent slope failures.
- Where
- Where diversion of upslope runoff is necessary to prevent damage to unstabilized or disturbed construction areas and other vulnerable areas such as steep slopes.
- How
1. Review site plan to determine areas subject to erosive surface runoff, construction areas needing protection from runoff, or collection and conveyance areas requiring runoff be directed into sediment basins or traps.
 2. Locate diversion ditches prior to excavation of area to be protected and with consideration of pre-construction drainage patterns and capacities.
 3. Temporary diversion ditches should be sized to carry at least a 10-year 24 hour storm event, unless local ordinances require greater capacity.
 4. Permanent diversion ditches should be sized by a professional engineer.
 5. Ditches should be located above, not on, a cut or fill slope and should run essentially perpendicular to the direction of runoff.
 6. Ditch should have a minimum 2' wide bottom, a minimum 18" depth, with side slopes 1:2 or flatter.
 7. Ditch grade minimum is usually 1%, maximum grade is dependent upon ditch armoring, capacity and diversion outlet (generally not greater than 10%).
 8. Ditches may be vegetated or stabilized with rock riprap or matting.



DIVERSION DITCH SPECIFICATIONS

How
(cont.)

9. Care should be taken to prevent placement of material from ditch excavation into waterbodies, wetlands, or other sensitive areas.
10. Excavated material sidecast along diversion ditch should be compacted and stabilized.
11. Seed and mulch ditches with less than 5% grade; riprap and sod ditches with greater than 5% grade.

Maintenance

- Diversion should be inspected after every rainfall.
- Sediment should be removed from the diversion ditch and repairs made as necessary.
- Mow to remove excess growth of woody vegetation (design consideration).
- Except for maintenance, keep vehicles out of the ditch.

Limitations

- Diversion ditches should not adversely impact upstream or downstream properties.
- Use may be limited by quantity of diverted runoff.
- Seeding ditches will delay use until cover established.



COFFERDAM

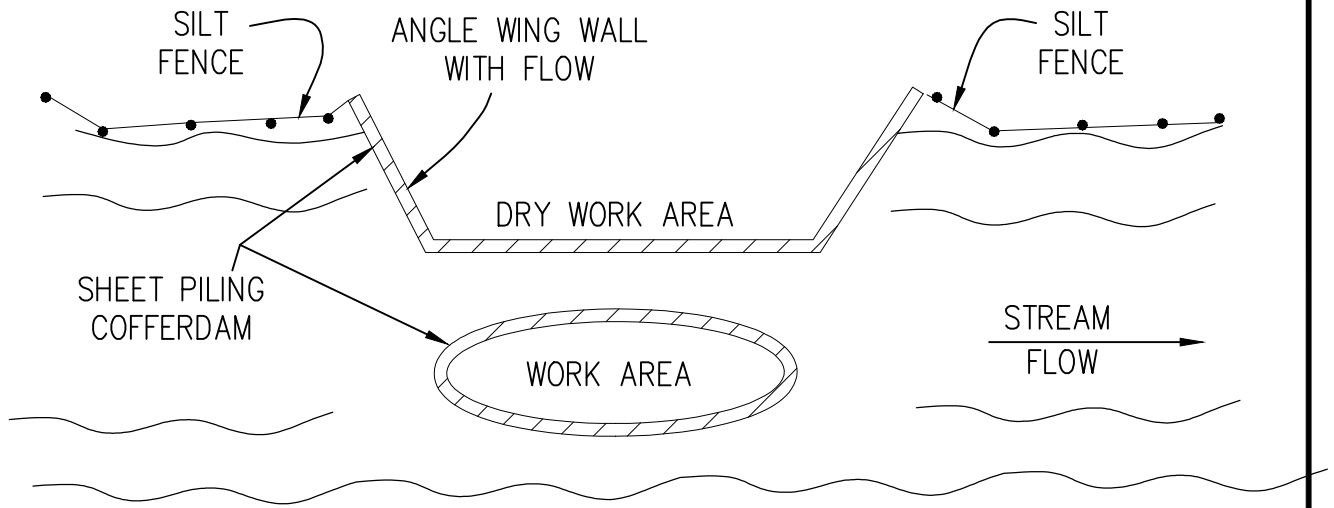

SHEET PILING COFFERDAM – TYPICAL PLAN

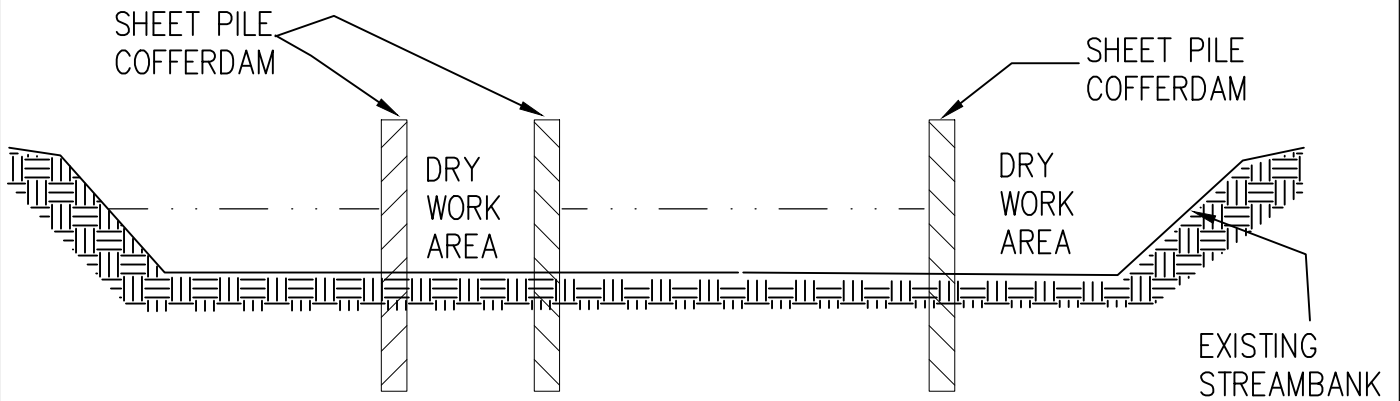

COFFERDAM CROSS-SECTION

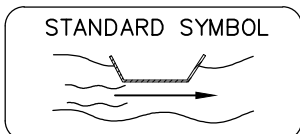

COFFERDAM SPECIFICATIONS

- When
- Use to keep water and sediment out of work area.
- Why
- Provides a dry work area where one would not otherwise exist.
 - Minimizes downstream sedimentation from construction within waterbody.
- Where
- Construct along or within a water corridor or waterbody.
- How
1. May be constructed of sheet pilings or similar material.
 2. Design of cofferdam should be done by an engineer. All design parameters should be considered to prevent overtopping during the initial closure of the cofferdam.
 3. In moving water, always angle wing wall with flow. Never place upstream wing perpendicular to flow.
 4. Pile drive sheet piling into the ground. Generally, sheet piling attaches in a tongue and groove system.
 5. Attach bracing system on the inside of the cofferdam.
 6. Begin dewatering through a filter bag (see dewatering specifications).
- Maintenance
- Cofferdams should be checked daily for excessive leaking and problems addressed immediately.
 - Proper safety techniques are to be used at all times while working in cofferdams, due to the limited access.
 - If working within a water corridor, additional safety measures may be required.
- Limitations
- Costly method of construction site preparation.
 - Improper coffer dam dewatering may result in sedimentation of receiving waterways.



COFFERDAM SPECIFICATIONS

Limitations
(cont.)

- Isolation walls perpendicular to stream flow will cause erosion and scouring.
- Working conditions may be hazardous if proper safety techniques are not used.
- Do not use during periods of peak flow or flooding.



STREAMBANK BIOSTABILIZATION

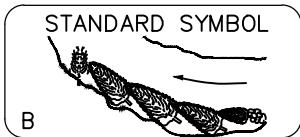
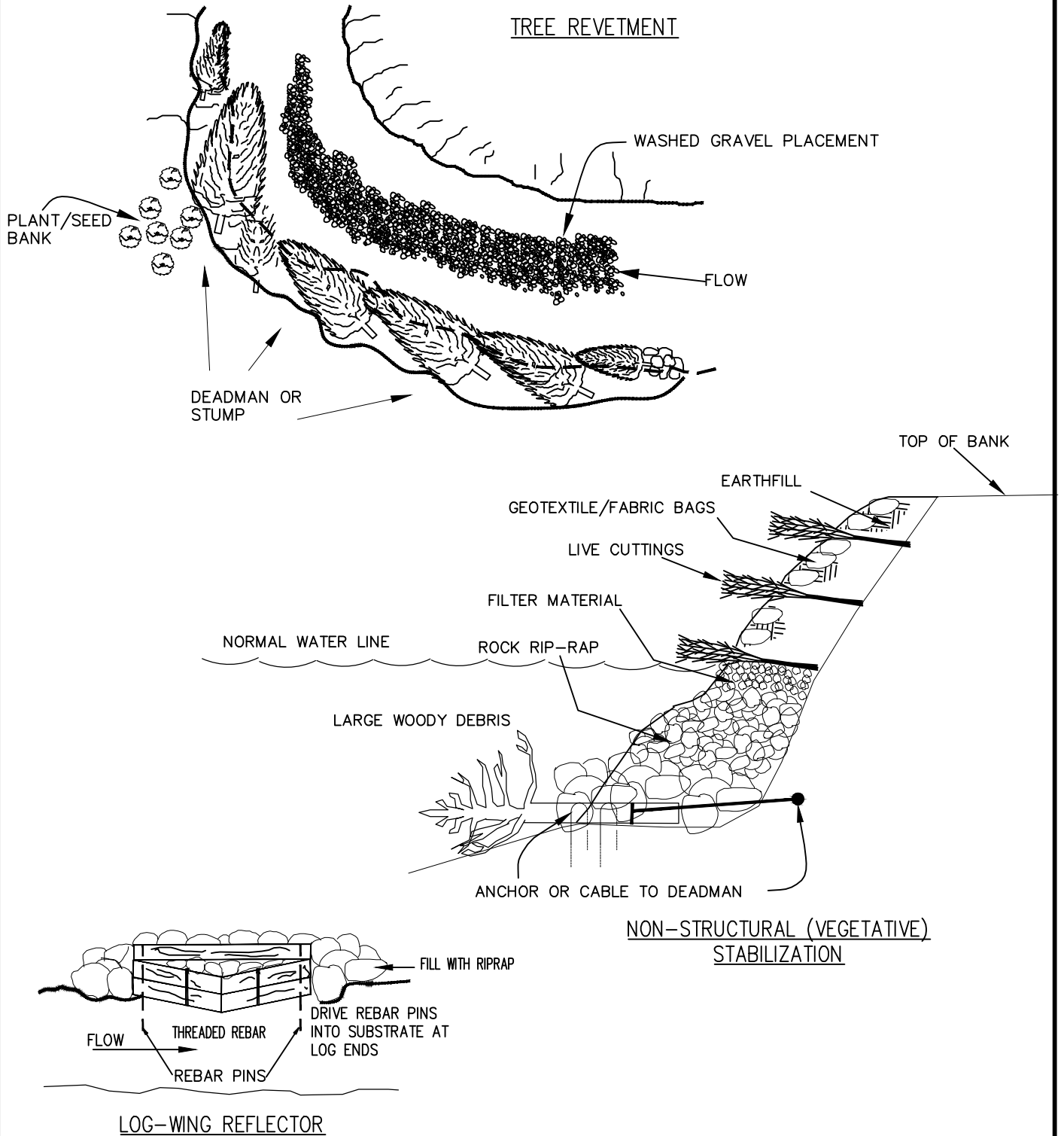

STREAMBANK BIOSTABILIZATION SPECIFICATIONS

ES39

- When
- Whenever vegetation can improve the stability of an eroding streambank.
- Why
- Stabilizes streambanks while reducing suspended sediments and increasing habitat.
- Where
- For use along banks where stream and riparian zones may have difficulty naturally recovering from the long-term effects of erosion.
- How
1. Various types of biostabilization techniques exist, including non-structural (vegetation), log wing-deflectors, and tree revetments.
 2. Non-structural approaches are methods utilizing native vegetation, soil and boulders to stabilize failing banks.
 3. Banks should not be reshaped if existing bank cover has the potential to stabilize the site.
 4. If vegetation is to be utilized, graded slopes should be flatter than 1:2.
 5. Native vegetation only should be utilized with consideration for soil type, bankslope, expected flow rates, ease of establishment, climate and plant growth habits.
 6. Install plant material in diverse communities, utilizing mulch blankets to aid establishment.
 7. Utilize woody vegetation at the toe of the bank with shrubs and grasses above.
 8. Log wing-deflectors are triangular objects which direct flow away from banks.
 9. Use wire fencing and non-woven geotextile fabric to create a basket which contains and secures the cobblestones from the stream.
 10. Fill the basket with cobblestones and use small boulders to anchor the logs.



**GRAND VALLEY
STATE UNIVERSITY.**



STREAMBANK BIOSTABILIZATION SPECIFICATIONS

How
(cont.)

11. Tree revetment is used to stabilize vertical, eroding streambanks.
12. If possible, use trees located in the area where the work is being done.
13. Dead trees may be used, but trees which will not deteriorate quickly are recommended.
14. Lay trees against the bank with the tops angling downstream.
15. Anchor the trees securely to the bank.

Maintenance

- During the first year of installation, inspect after heavy rains to insure the stabilization is working properly.
- After the first year, inspections should be made annually to check for additional eroding or deteriorating of the anchors or trees.
- Replace trees or anchors when necessary.

Limitations

- Expense, as this approach is labor intensive.
- Bank shading may inhibit establishment of vegetation.



**GRAND VALLEY
STATE UNIVERSITY.**

POLYMERS

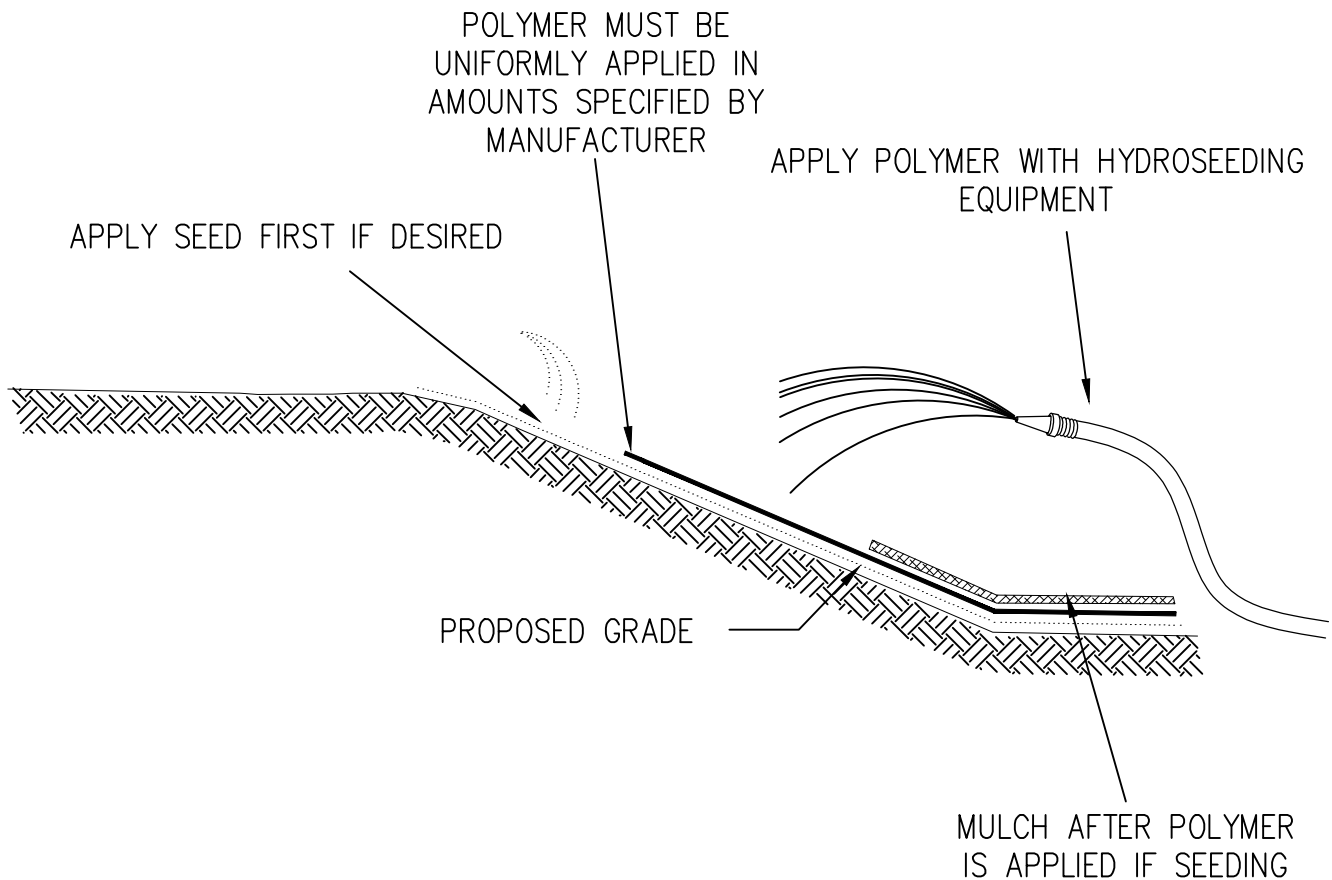

NOTES:

- Not for use in channels.
- Only the ANIONIC form of Polyacrylamide (PAM) shall be used. The cationic form of PAM is toxic to wildlife and plants and shall not be used.
- When used alone, not in combination with seed or mulch, polymers should only be used on slopes 1:3 or flatter.

STANDARD SYMBOL



GRAND VALLEY
STATE UNIVERSITY.

POLYMER SPECIFICATIONS

- When
- To stabilize soil temporarily exposed during construction activities, or when seeding or mulching slopes.
- Why
- To minimize soil erosion and reduce sedimentation in water bodies.
- Where
- On disturbed construction sites prone to sediment loss.
- How
1. When choosing a brand of polymer to use, utilize only polymers approved by the MDEQ Surface Water Quality Division.
 2. Apply the approved polymer either with conventional hydraulic seeding equipment, or by dry spreading.
 3. When mixing the polymer solution, the dry polymer shall be introduced into the water in the hydraulic seeder at a rate of no more than 2 lbs. per minute while agitation is applied. The solution must be agitated for an additional 5 minutes after the polymer has been added.
 4. Polymer must be spread uniformly to maintain $\leq 0.05\%$ acrylic monomer by weight (as established by FDA and EPA).
 5. Application rate of pure PAM must not exceed 10 lbs per acre. Follow all manufacturer's directions carefully for correct rate of application.
 6. Soil surface must be completely wetted to ensure proper functioning of the polymer. This may require a second pass spraying from a different direction. Typically, $3000\pm$ gallons of water per acre shall be consumed.
 7. When using soil stabilizers in seeding slopes, seed must be applied first to insure direct contact of seed with soil. The soil stabilizer is then applied to the slope, followed by a mulch to protect the seed.



POLYMER SPECIFICATIONS

- Maintenance
- Since polymer is normally only applied once, maintenance is minimal.
- Limitations
- For temporary use only (6 mos. or less).
 - Not for use in channels.
 - Polymers can be toxic to fish, wildlife, and plants if improperly applied or if the wrong polymer is used. Polymers must be spread uniformly and only in amounts specified by the manufacturer.
 - Only the ANIONIC form of polyacrylamide (PAM) shall be used. The cationic form of PAM is toxic to wildlife and plants and shall not be used.



WATTLES

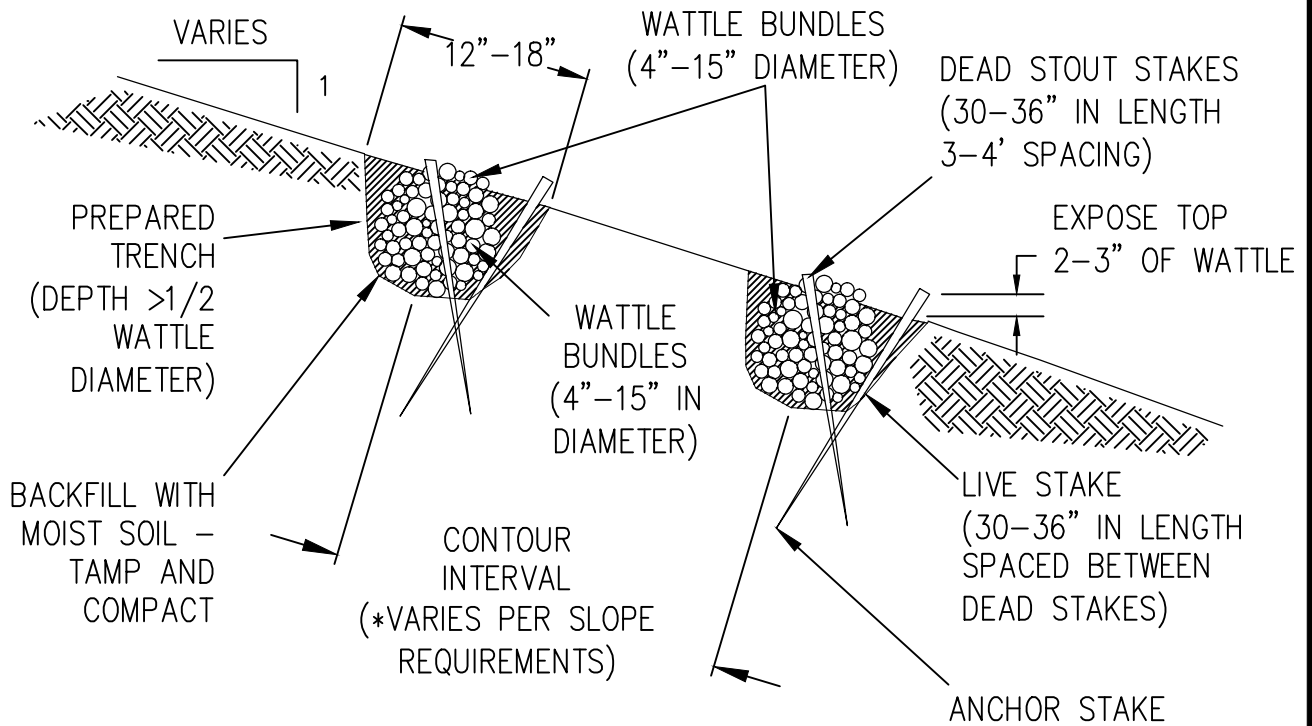

* SPACING INTERVAL

SLOPE	1:1	1:2	1:3	1:4	1:6
CONTOUR INTERVAL	3'	4'	5'	6'	8'

ADAPTED FROM NRCS, SOMERSET, NJ

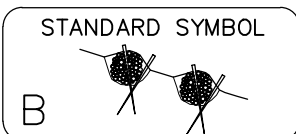
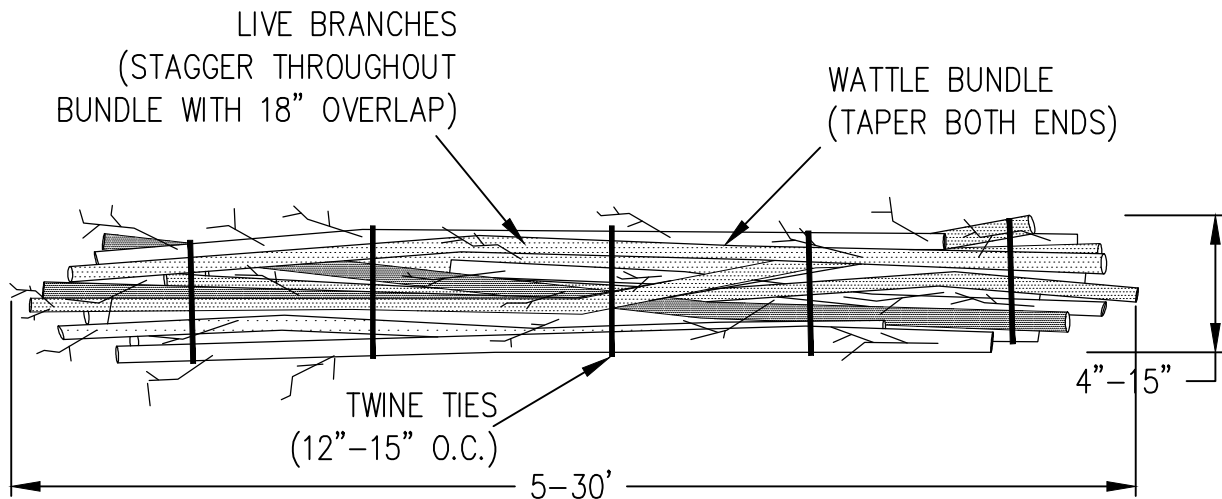

WATTLES SPECIFICATIONS

ES41

- When
- When vegetation establishment can prevent or reduce gully formation and erosion on slopes.
 - To inhibit soil movement and gully formation.
- Why
- In areas requiring immediate protection of slopes against surface erosion and gully formation.
- Where
- In areas requiring stabilization but with limited access for equipment or when relatively little site disturbance during installation is preferred.
 - On cut and fill slopes or other earth embankments, including dunes, shorelines, and streambanks requiring stabilization.
 - In wetland buffers or reservoir drawdown areas where plants may be submerged for extended periods.
- How
1. Review slope steepness to determine necessary spacing interval, trench length, and material needs. (Consult table for appropriate spacing interval.)
 2. Lay out contour interval on slope.
 3. Identify a suitable source of locally appropriate vegetation. Choose species appropriate for soil type, habitat, and other specific site characteristics (See Live Staking E21 for suitable species).
 4. Prepare dead stout stakes 30–36” in length by diagonally cutting 2 X 4s across the 4” width to make 2 stakes from each 2X4.
 5. Prepare wattle 4–15” in diameter, to desired length, with tapered ends, bound with twine every 12–15”. Material is best collected following onset of late fall up to early spring break of dormancy.
 6. Starting at slope base, hand dig trench 12–18” wide along level contour, deep enough to accommodate most of the wattle diameter.



**GRAND VALLEY
STATE UNIVERSITY.**

WATTLES SPECIFICATIONS

How
(cont.)

7. Place wattle in prepared trench.
8. Drive dead stout stakes into slope, spacing them 2–3' apart, directly through wattle along its entire length.
9. Install live stakes between dead stakes on downslope side of bundle. Leave live stakes protruding 2–3" above wattle.
10. Backfill trench with moist soil along side of wattle leaving top 2–3" of wattle exposed. Compact soil to eliminate air pockets around buried wattles.
11. Move upslope the appropriate contour interval distance, repeat preceding steps. Repeat process until reaching top of slope.
12. Mulch between wattles, using mulch blankets on slopes 1:2 or steeper.

Maintenance

- All installations should be inspected regularly and provisions made for prompt repair if needed. Small failures can generally be repaired easily but quickly lead to larger failures if unattended.
- Periodic pruning and replanting of live stakes may be required to maintain healthy and vigorous vegetation growth.

Limitations

- Labor intensive.
- Use may be limited by availability of live stakes.

Appendix 6

S51

SILT FENCE

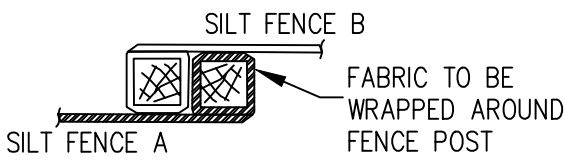
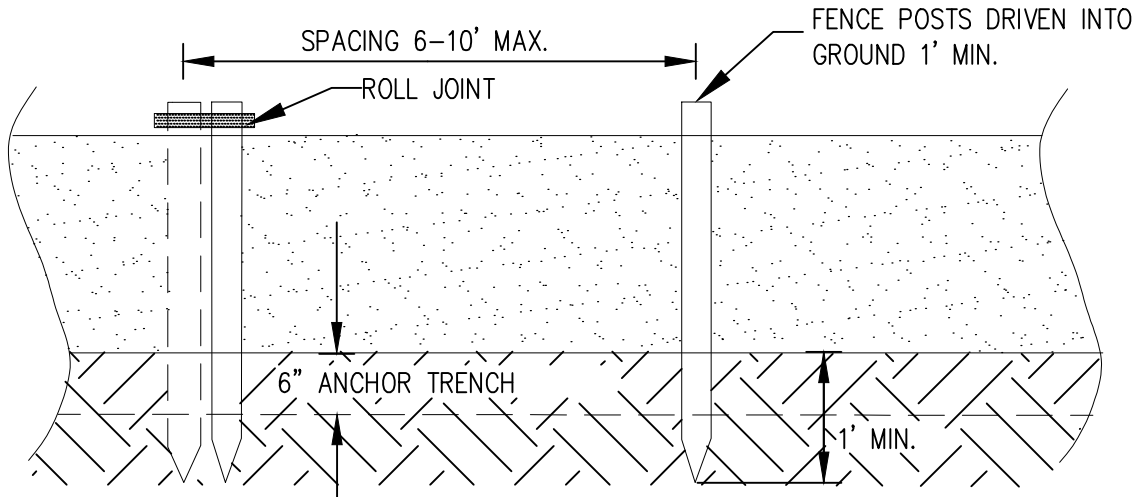

ROLL JOINTS

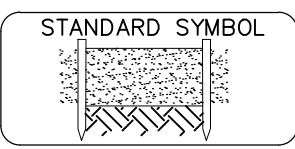
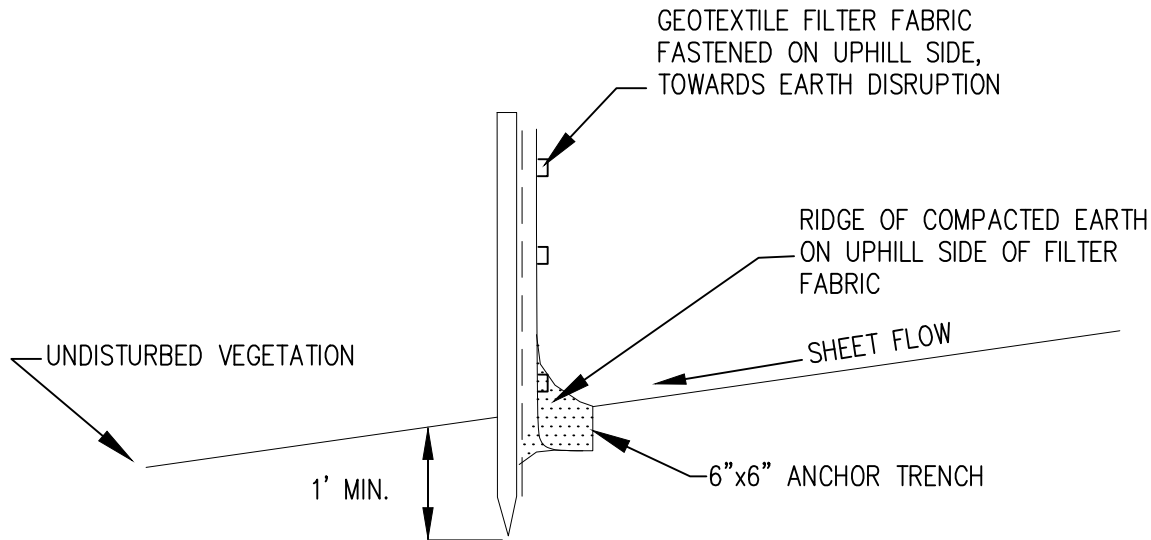

SILT FENCE SPECIFICATIONS

- When
- A temporary measure for preventing sediment movement.
- Why
- Used to prevent sediment suspended in runoff from leaving an earth change area.
- Where
- Use adjacent to critical areas, wetlands, base of slopes, and watercourses.
- How
1. Install parallel to a contour.
 2. The silt fence should be made of woven geotextile fabric.
 3. Silt fence should accomodate no more than 1/2 to 1 acre of drainage per 100' of fence and on slopes less than 1:2 (v:h).
 4. Dig a 6" trench along the area where the fence is to be installed.
 5. Place 6" of the silt fence bottom flap into the trench.
 6. Backfill the trench with soil and compact the soil on both sides. Create a small ridge on the up-slope side of the fence.
 7. Install wooden stakes 6 – 10' apart and drive into the ground a minimum of 12".
 8. Staple the geotextile fabric to the wooden stakes.
 9. Join sections of silt fence by wrapping ends together (See drawing).
- Maintenance
- Inspect frequently and immediately after each storm event. Check several times during prolonged storm events. If necessary, repair immediately.
 - If the sediment has reached 1/3 the height of the fence, the soil should be removed and disposed of in a stable upland site.
 - The fence should be re-installed if water is seeping underneath it or if the fence has become ineffective.
 - Silt fence should be removed once vegetation is established and up-slope area has stabilized.



S51

SILT FENCE SPECIFICATIONS

Limitations

- Silt fence may cause temporary ponding and could fail if too much water flows through the area.
- Do not use in areas with concentrated flows.
- Chance of failure increases if fence is installed incorrectly or if sediment accumulation is not removed.



**GRAND VALLEY
STATE UNIVERSITY.**

S52

CATCH BASIN SEDIMENT GUARD

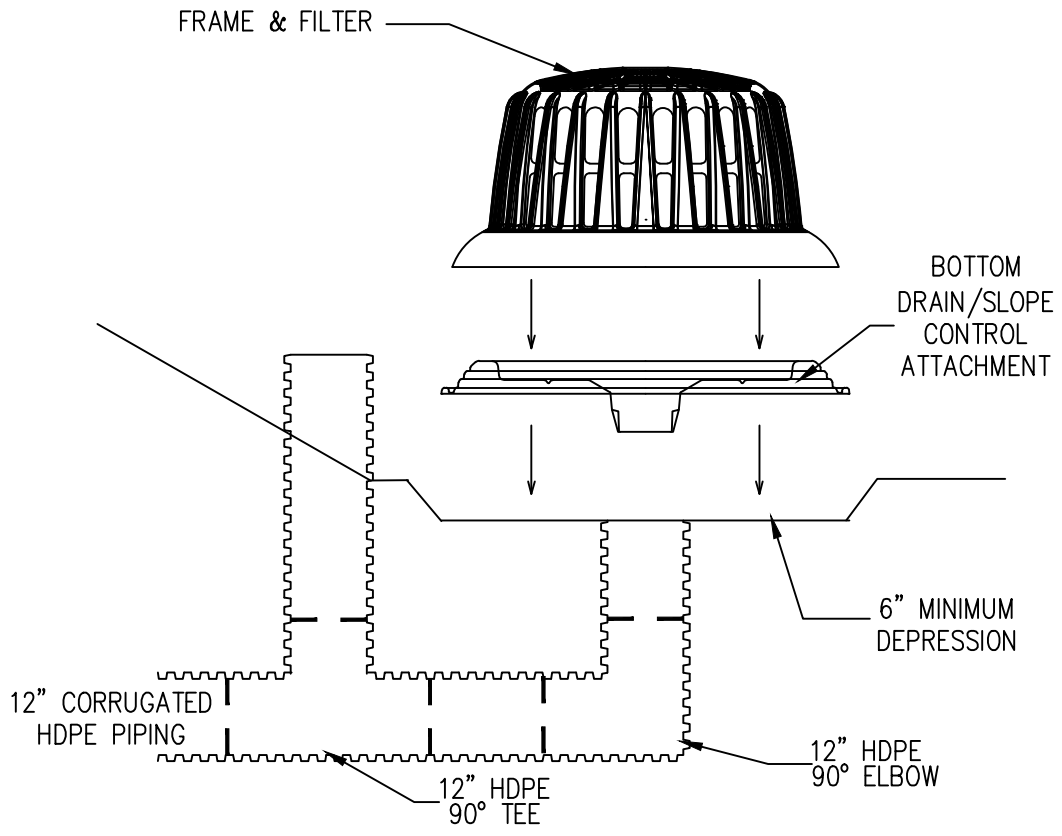

INSTALLATION PROFILE

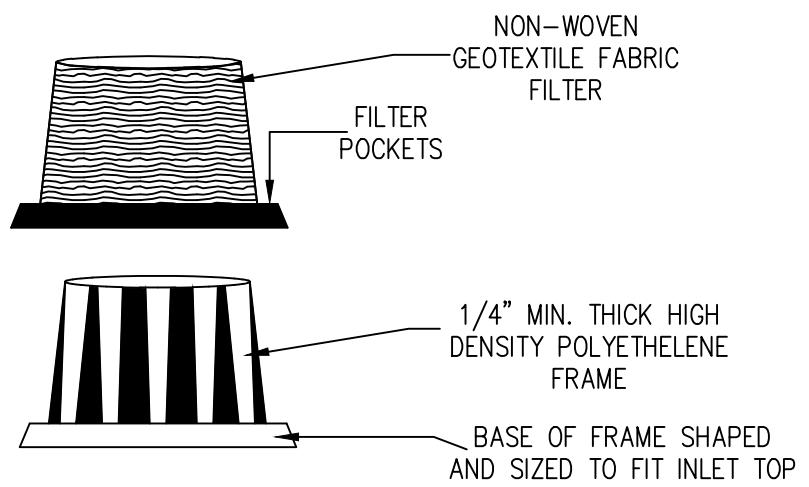

FILTER & FRAME PROFILE

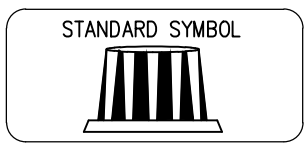

Adapted from: Silt-Saver, Inc.



CATCH BASIN SEDIMENT GUARD SPECIFICATIONS



- When
- On construction sites when incomplete stormwater systems require protection from sediment-laden stormwater.
- Why
- To prevent sediment from entering stormwater systems.
- Where
- Use on construction sites for unfinished stormwater inlets.
- How
1. Excavate approximately 4" – 6" below the top of the inlet structure.
 2. Place the frame onto the inlet structure, ensure the frame covers the structure completely.
 3. Slide the filter over the frame.
 4. Fill the filter pockets with soil, gravel or equivalent. The filter pockets should be completely filled to ensure a good seal between the ground and inlet structure.
 5. Back-fill around the frame and filter assembly is not required to complete installation, though it may be necessary to complete excavation requirements for the site.
- Maintenance
- Sediment removal from the filter is necessary when the sediment build-up reaches a point of 65% of the total height of the frame or approximately 7" – 9" of the non-woven filter fabric is showing.
 - Remove the material by hand or mechanically, paying attention not to damage the frame or filter.
 - Brush, sweep, or wash filter and frame and inspect for any damage. Replace filter and/or frame as needed.
 - If filter or frame is replaced, remember to refill filter pockets and back-fill as required by site conditions.
- Limitations
- Not a permanent sedimentation control method.
 - Only suitable for use on structural stormwater outlets.



S53

STABILIZED CONSTRUCTION ACCESS

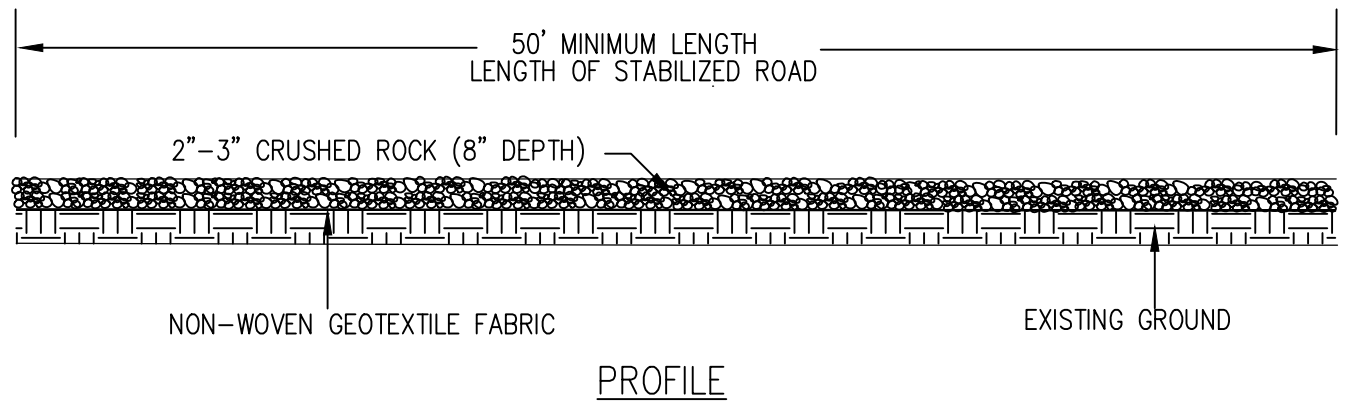
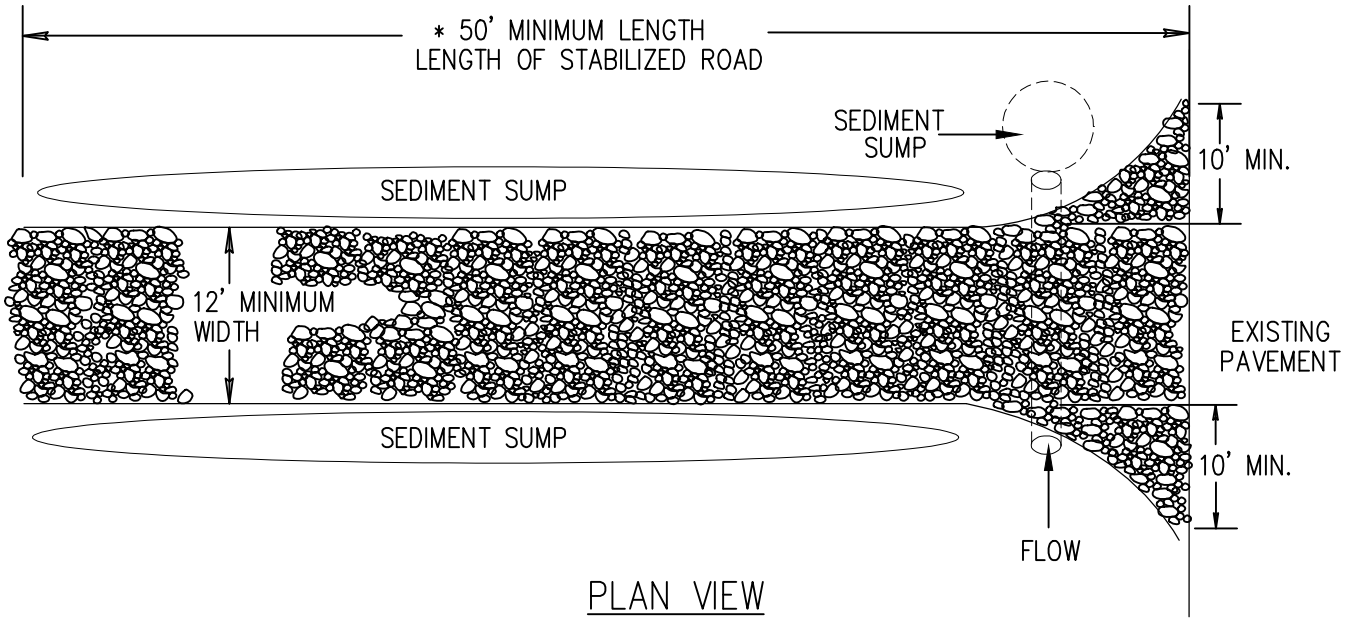

NOTES:

1. Establish stabilized construction entrance prior to the initiation of site construction activities.
2. Care should be taken to prevent material movement into adjacent wetlands/waterbodies.
3. Care should be taken to maintain existing roadside drainage via culvert installation, with sediment sump placed downflow of culvert.

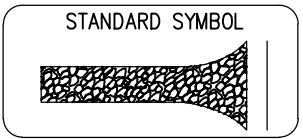

STABILIZED CONSTRUCTION ACCESS SPECIFICATIONS

S53

- When
- Construction traffic is expected to leave a construction site.
 - Stabilization of interior construction roads is desired.
- Why
- To minimize tracking of sediment onto public roadways and to minimize disturbance of vegetation.
- Where
- Stabilized construction entrances shall be located at every point where construction traffic enters or leaves a construction site. Vehicles leaving the site must be routed over the rock ingress/egress corridor.
- How
1. Stabilized construction access road should be established at the onset of the construction activities and maintained in place for the duration of the construction project.
 2. Installation of this practice should be the responsibility of the site clearing or excavating contractor.
 3. Access location should be cleared of woody vegetation.
 4. Non-woven geotextile fabric shall be placed over the existing ground prior to placing stone.
 5. Access size should be a minimum of 50'. (30' for single residence lot).
 6. Access width should be 12' minimum, flared at the existing road to provide a turning radius.
 7. Crushed aggregate (2" to 3"), or reclaimed or recycled concrete equivalent, shall be placed at least 8" deep over the length and width of the ingress/egress corridor.
- Maintenance
- Periodic inspection and needed maintenance shall be provided after each rain event.
 - Stabilized entrances shall be repaired and rock added as necessary.



**GRAND VALLEY
STATE UNIVERSITY.**

STABILIZED CONSTRUCTION ACCESS SPECIFICATIONS

S53

- Maintenance (cont.)
- Sediment deposited on public rights-of-way shall be removed immediately and returned to the construction site.
 - If soils are such that washing of tires is required, it shall be done in a wash rack area, stabilized with stone, immediately prior to the construction access stabilized corridor.
 - At the project completion, rock access road should be removed and disposed of unless utilized as subgrade for final road.
- Limitations
- Effectiveness limited, sediment may be tracked onto roads requiring additional action.



**GRAND VALLEY
STATE UNIVERSITY.**

TIRE WASH

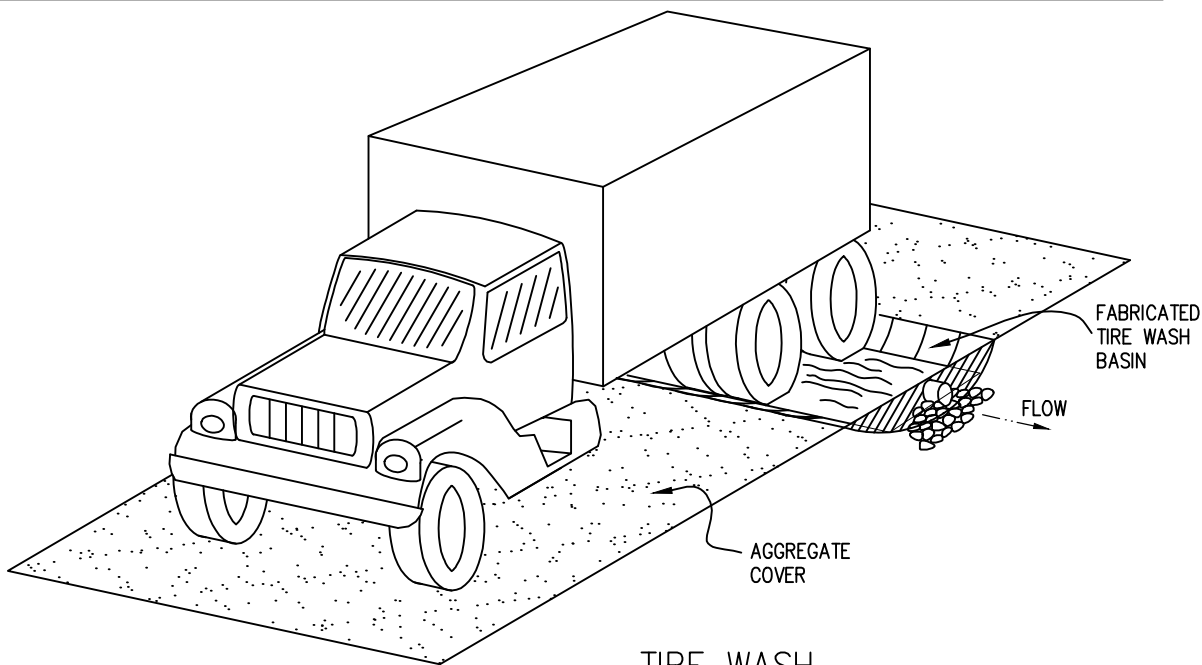

TIRE WASH

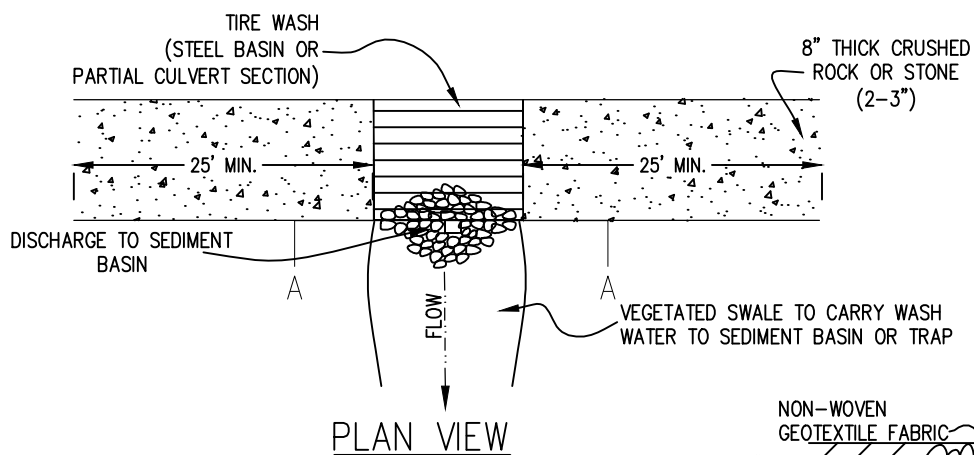

PLAN VIEW

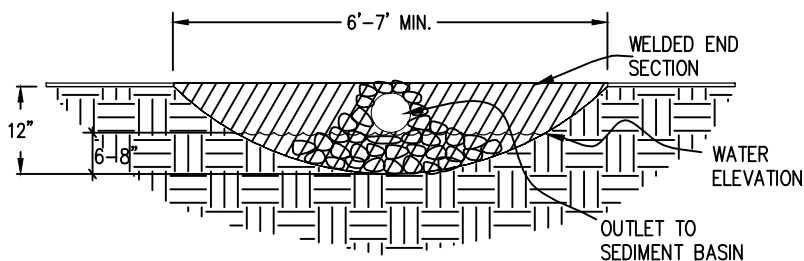

CROSS SECTION A-A

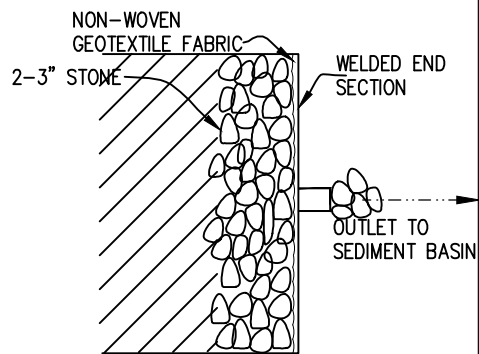

WASH OUTLET DETAIL

STANDARD SYMBOL



TIRE WASH SPECIFICATIONS

- When
- Whenever traffic will be entering or leaving a construction site with soil capable of clinging onto construction vehicles; resulting in tracking of mud onto paved roads.
- Why
- Reduces excessive sediment tracking of soil onto paved roads.
- Where
- As an addition to aggregate construction entrances.
- How
1. Construct tire wash on level ground at minimum length of 6'-7', a minimum of 10' wide to match width of aggregate road.
 2. Construct 25' minimum approaches to tire wash with minimum 8" thickness of 2-3" stone.
 3. Construct tire wash of partial culvert section or fabricated metal. Weld metal plates to culvert ends to contain water.
 4. Provide outlet on one end of tire wash to allow excess water to drain. Outlet invert should be located 6-8" above bottom of tire wash.
 5. Within tire wash structure, protect outlet pipe with non-woven geotextile fabric and 2-3" stone to prevent sediment discharge.
 6. Protect swale with 2-3" stone on non-woven geotextile fabric.
 7. Fill tire wash basin with water daily or when water depth is reduced to 1/2 the distance between basin bottom and outlet point.
 8. Wash rack discharges should be directed into a sediment basin through a vegetated channel.
 9. Remove sediment accumulation daily.

S54

TIRE WASH SPECIFICATIONS

Maintenance

- Sediment accumulation in wash shall be removed regularly and placed into proper disposal location.
- Maintain to specified dimensions by adding approach rock when necessary each day.
- Monitor water levels throughout working hours.
- Discharge swale should be inspected regularly to ensure tire wash discharge path is maintained to receiving sediment basin.
- Damage to tire wash shall be repaired prior to additional use of rack.

Limitations

- Requires daily maintenance.
- May not clean tire tread completely.



**GRAND VALLEY
STATE UNIVERSITY.**

S55

SEDIMENT BASIN

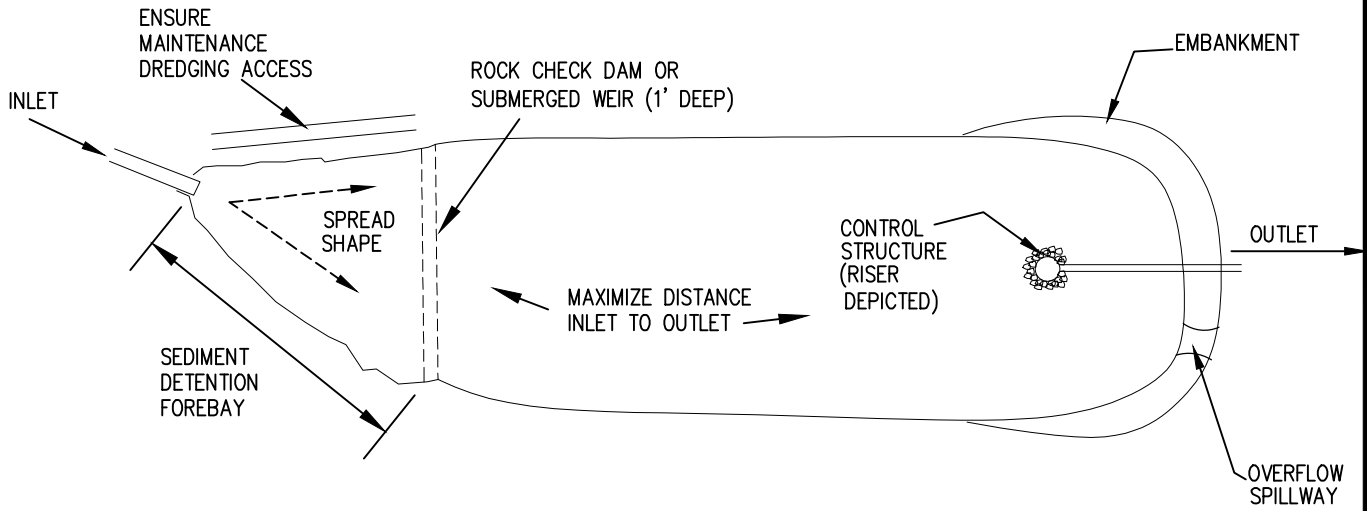

PLAN VIEW

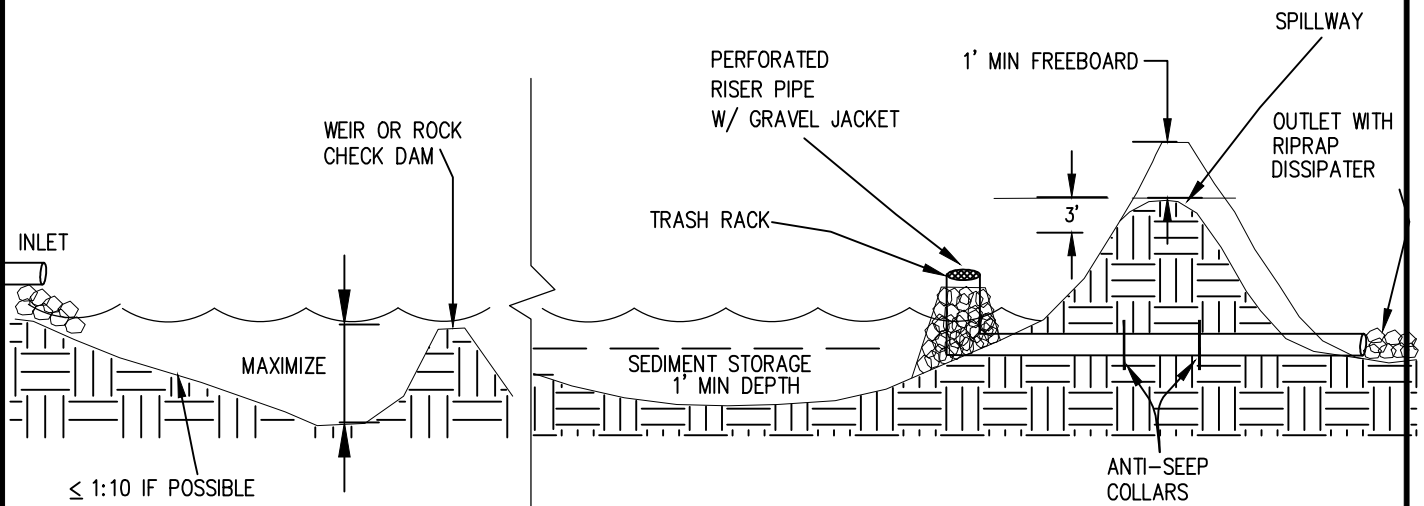

FOREBAY CROSS SECTION

EMBANKMENT/CONTROL CROSS SECTION

STANDARD SYMBOL

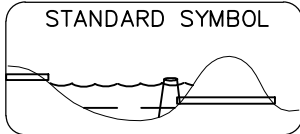

**GRAND VALLEY
STATE UNIVERSITY**

SEDIMENT BASIN SPECIFICATIONS

S55

- When
- When site runoff is sediment-laden and/or runoff release rate is required.
- Why
- To detain runoff sufficiently to allow excessive sediment to settle out before stormwater leaves construction site.
- Where
- At the outlet of any disturbed area or at the ultimate site outlet.
 - Should be used in association with dikes, temporary channels, and pipes to divert stormwater from the disturbed areas into the basin.
 - May be combined with permanent detention basin.
- How
1. Basin to be designed by engineer or CPESC to ensure adequate storage volume from the contributing drainage area.
 2. Basins should be constructed before clearing and grading work begins.
 3. Basins should be located at the stormwater outlet for the site and multiple basins may be located throughout the site.
 4. Basin location should ensure suitable access for maintenance and cleanout.
 5. Do not locate in a stream.
 6. All basin sites should be located where embankment failure will not compromise safety or result in property damage.
 7. The basin volume should be designed to handle the volume of stormwater expected from the disturbed acreage for a minimum 10-year storm event.
 8. The basin volume consists of two zones
 - A sediment storage zone to a 1' minimum depth.
 - A settling zone at least 2 feet deep.



**GRAND VALLEY
STATE UNIVERSITY.**



SEDIMENT BASIN SPECIFICATIONS

How
(cont.)

9. Design should contain sufficient capacity to detain runoff for 24–48 hours, maximizing sediment settlement potential.
10. Length to width ratio should be greater than 4:1 to allow for sufficient settlement time.
11. Utilize a well anchored riser pipe with anti-seep collars as the principal outlet, along with an emergency overflow spillway for major events.

Maintenance

- Inspect weekly and after each major storm event.
- Check the depth of sediment deposit to insure capacity of basin storage is adequate for stormwater and sediment deposition.
- Remove sediment when the forebay or basin design depth is 50% full of sediment.

Limitations

- Liability concerns based on failure of the basin and flooding of adjacent properties.
- May become an attractive nuisance to children and waterfowl.
- Typically, permanent basins are used for drainage of 5 acres or more.
- Effective in removing sediment down to the medium silt size fraction, however, not effective with fine silt and clay without extending detention time.



S56

SEDIMENT TRAP

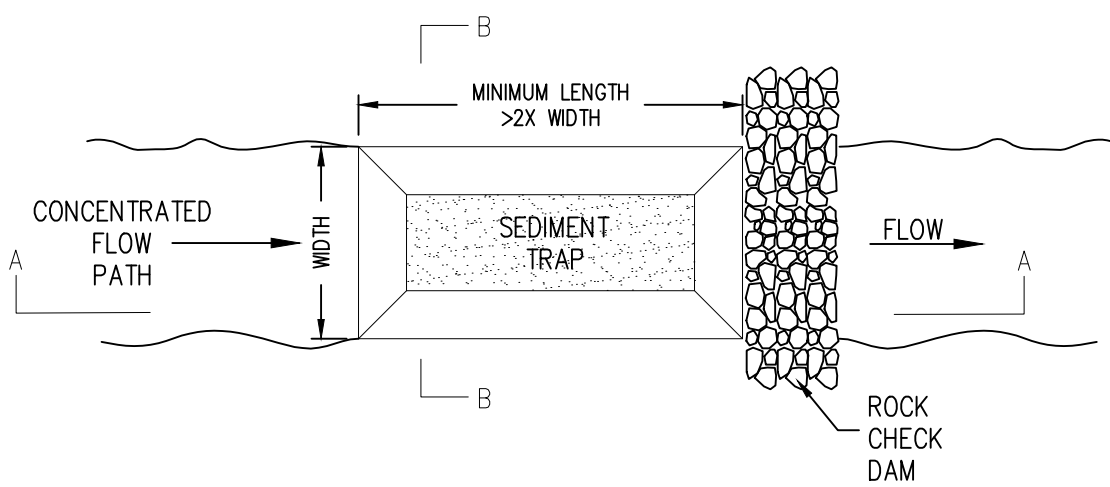

PLAN VIEW

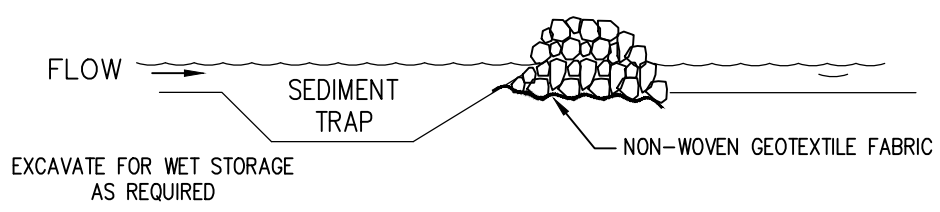

CROSS SECTION AA

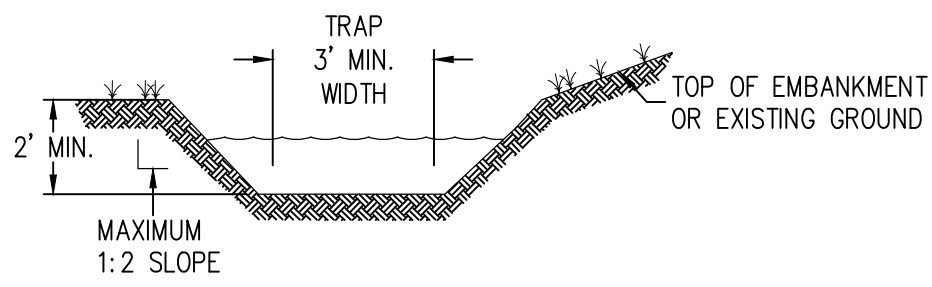

CROSS SECTION BB

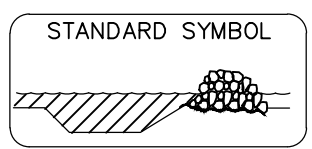

SEDIMENT TRAP SPECIFICATIONS

- When**
- When runoff from construction sites contains suspended sediment.
- Why**
- Should be used as a temporary measure.
 - To collect and store sediment from sites cleared and/or graded during construction.
- Where**
- In small drainage areas with less than 5 acres of contributing drainage.
 - Along the construction site perimeter where runoff is discharged offsite.
 - Above check dams and/or upslope of drain inlet protection measures.
- How**
1. Prior to construction initiation, identify stormwater drainage routes likely to carry construction site runoff.
 2. Build sediment traps in site runoff corridors before clearing, grubbing, and grading begin.
 3. Install traps in natural depressions or in small drainageways to minimize vegetation removal.
 4. A sediment trap is intended as a temporary measure.
 5. In-stream applications should be designed by a professional engineer, with consideration for the type of soil, size of drainage area, and desired sediment removal efficiency.
 6. Locate where the trap can be easily cleared of sediment.
 7. Collection channels should enter the trap from the upslope side.
 8. The sediment trap should have a minimum length to width ratio of 2:1.
 9. The outlet of the trap must be stabilized with rock, vegetation, or another suitable material.



SEDIMENT TRAP SPECIFICATIONS

Maintenance

- Sediment shall be removed and trap restored to its original dimensions when the sediment has accumulated to 1/2 the design depth of the trap. Removed sediment shall be deposited in an upland area in such a manner that it will not erode.
- The structure shall be inspected after each rain event and repairs made as needed.
- The sediment trap shall be removed and the area stabilized when the contributory drainage area has been properly stabilized. The swale sediment trap will be properly backfilled and the swale or ditch reconstructed.

Limitations

- Only use for drainage areas up to 5 acres.
- Removes coarse sediment only (medium silt size or larger) unless trap area is sized similar to a sediment basin with extended residence time.



VEGETATED BUFFER/FILTER STRIP

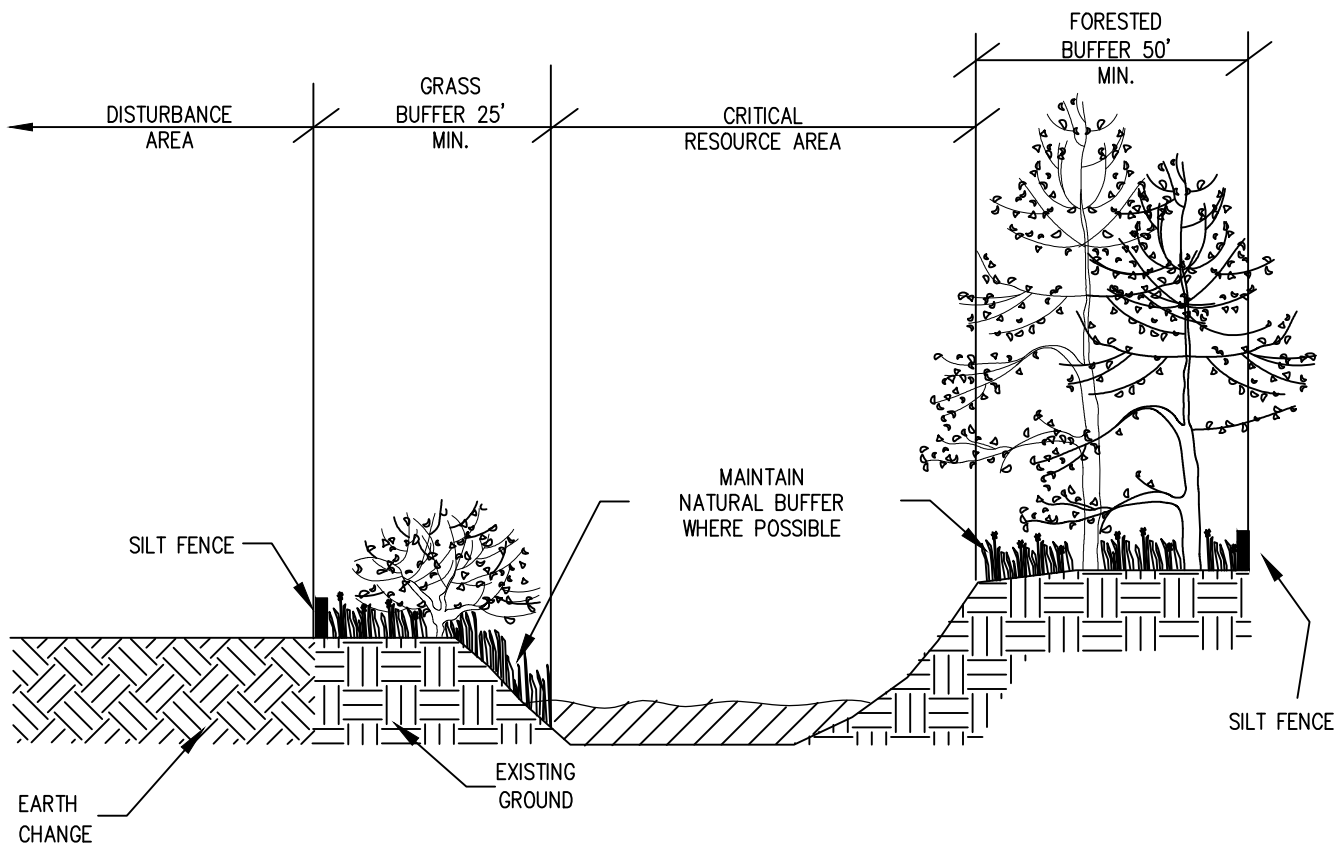

FILTER STRIP LENGTH TO REMOVE SEDIMENT FROM RUNOFF

SLOPE (%) OF CONTRIBUTING AREA ABOVE FILTER STRIP	LENGTH OF FLOW (FT.) BY HYDROLOGIC SOIL GROUP OF FILTER AREA **			
	A	B	C	D
0 - 1	20	20	22	24
1 - 3	20	25	28	30
3 - 5	24	30	33	36
5 - 8	28	35	40	42
8 - 12	32	40	44	48
12 - 15	40	50	55	60
15 - 20	48	60	66	72
> 20	*	*	*	*

* For slopes that exceed 20% consult NRCS technical specialist for design guidance.

** Hydrologic Soil Groups, as defined in U.S.D.A., Natural Resources Conservation Service Engineering Field Manual, Section 2, Page 2

TABLE: FROM NRCS TECHNICAL GUIDE, FILTER STRIP 393-A

NOTES:

1. MINIMUM GRASS/SOD FILTER STRIP = 25 FEET, MINIMUM FORESTED WIDTH = 50'
2. BUFFER STRIP WIDTH IS DEPENDENT ON LENGTH AND STEEPNESS OF SLOPE, VEGETATION TYPE, AND SOIL TYPE.
3. THE LARGER THE BUFFER WIDTH, THE MORE EFFECTIVE AND BENEFICIAL IT IS.

STANDARD SYMBOL



VEGETATED BUFFER/FILTER STRIP SPECIFICATIONS

S57

- When
- When resource area protection is necessary adjacent to disturbed construction sites.
- Why
- To trap and filter sediment suspended in runoff.
- Where
- Appropriate for use in sheet flow areas, not concentrated flow areas.
 - Between disturbed areas and resource to be protected.
 - Adjacent to all sensitive areas that could be detrimentally impacted by loadings of sediment, organic matter, nutrients, or pesticides.
- How
1. Identify sensitive resource areas (waterbodies/wetlands) prior to the initiation of site grading activities.
 2. When possible, existing natural buffer/filter strips should be maintained, especially along watercourses.
 3. Buffer/filter strip areas should be identified and protected by silt fence prior to any construction.
 4. For creation of new buffer/filter strips, determine the drainage characteristics, slope steepness, slope length, type of soil, and necessity of irrigation.
- Maintenance
- Keep concentrated flows away from buffer/filter strip.
 - Keep equipment out of proposed and existing buffer/filter strip areas.
 - In created buffer/filter strip areas, protect sensitive resource area with silt fence until vegetation is established.
 - If damage occurs due to runoff, additional soil erosion controls should be installed to divert flows away from buffer/filter strip.
 - Irrigate newly created buffer/filter strip if necessary until vegetation is established.
 - Annual mowing should be conducted on grass buffer/filter strips to prevent unwanted species growth. Mow no closer than 6 inches.



**GRAND VALLEY
STATE UNIVERSITY.**

S57

VEGETATED BUFFER/FILTER STRIP SPECIFICATIONS

- Maintenance (cont.)
- When establishing a buffer/filter strip, clip unwanted and invasive vegetation in the first year to inhibit growth. After the first year, only conduct spot clipping of such species.
 - Clipping and mowing should only be done between July 15 and August 15 to minimize potential wildlife impact.
 - Select only native species for use in buffer/filter strips when possible.
 - Do not spray buffer/filter strips with pesticides or herbicides.
- Limitations
- Construction activities could damage buffer/filter vegetation unless protective measures are taken.



**GRAND VALLEY
STATE UNIVERSITY.**

S58

INLET PROTECTION – FABRIC DROP

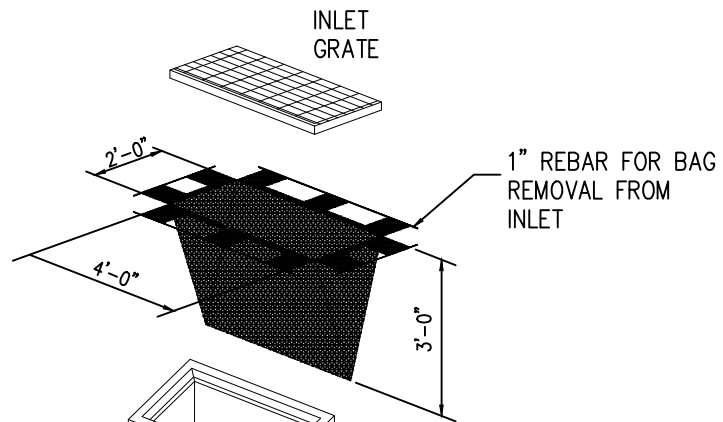

ISOMETRIC VIEW

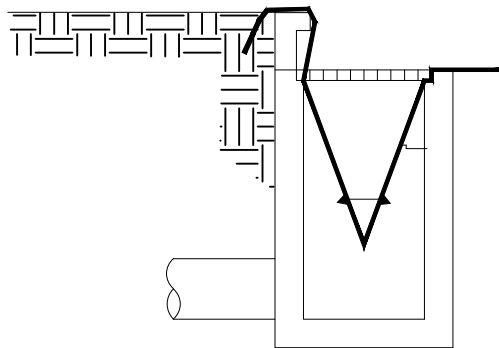

INSTALLATION DETAIL

STANDARD SYMBOL



GRAND VALLEY
STATE UNIVERSITY.

INLET PROTECTION – FABRIC DROP SPECIFICATIONS

S58

- | | |
|-------------|--|
| When | <ul style="list-style-type: none">• When sediment laden stormwater requires treatment before entering a stormwater drainage system. |
| Why | <ul style="list-style-type: none">• To prevent sediment from entering stormwater systems. |
| Where | <ul style="list-style-type: none">• Use in or at stormwater inlets, especially at construction sites or in streets. |
| How | <ol style="list-style-type: none">1. A filter fabric bag is hung inside the inlet, beneath the grate.2. Replace grate, which will hold bag in place.3. Anchor filter bag with 1” rebar for removal from inlet.4. Flaps of bag that extend beyond the bag can be buried in soil in earth areas. |
| Maintenance | <ul style="list-style-type: none">• Drop inlet filters should be inspected routinely and after each major rain event.• Damaged filter bags should be replaced.• Clean and/or replace filter bag when 1/2 full.• Replace clogged fabric immediately.• If needed, initiate repairs immediately upon inspection.• Remove entire protective mechanism when upgradient areas are stabilized and streets have been swept. |
| Limitations | <ul style="list-style-type: none">• Can only accommodate small flow quantities.• Requires frequent maintenance.• Ponding may occur around storm drains if filter is clogged. |



**GRAND VALLEY
STATE UNIVERSITY.**

S59

INLET PROTECTION – FABRIC FENCE

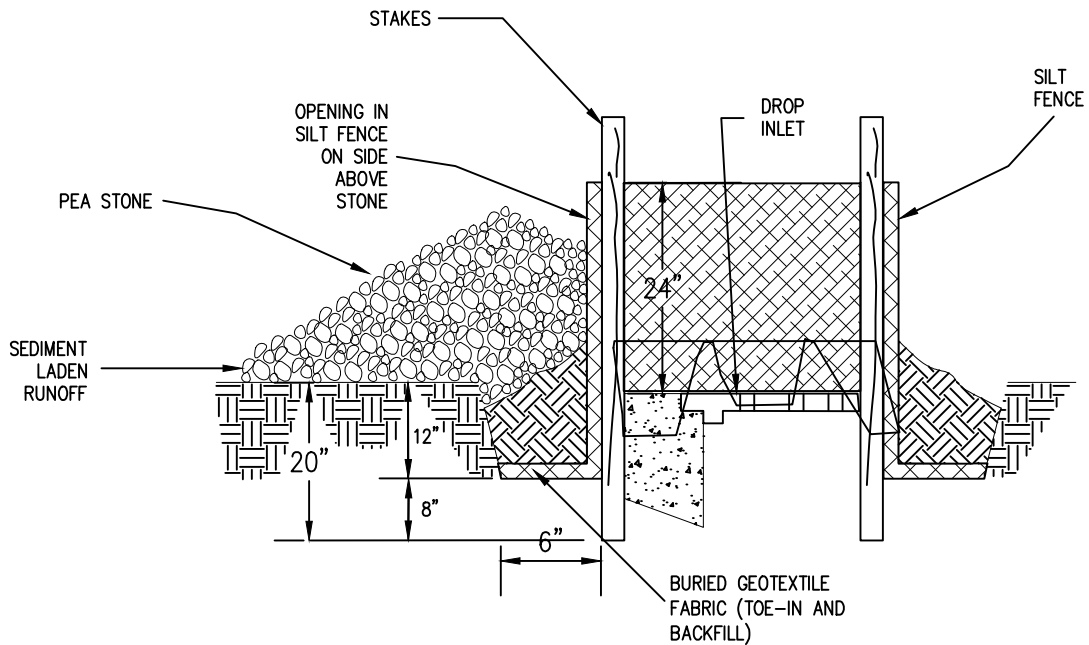

CROSS-SECTION OF SILT FENCE INLET FILTER

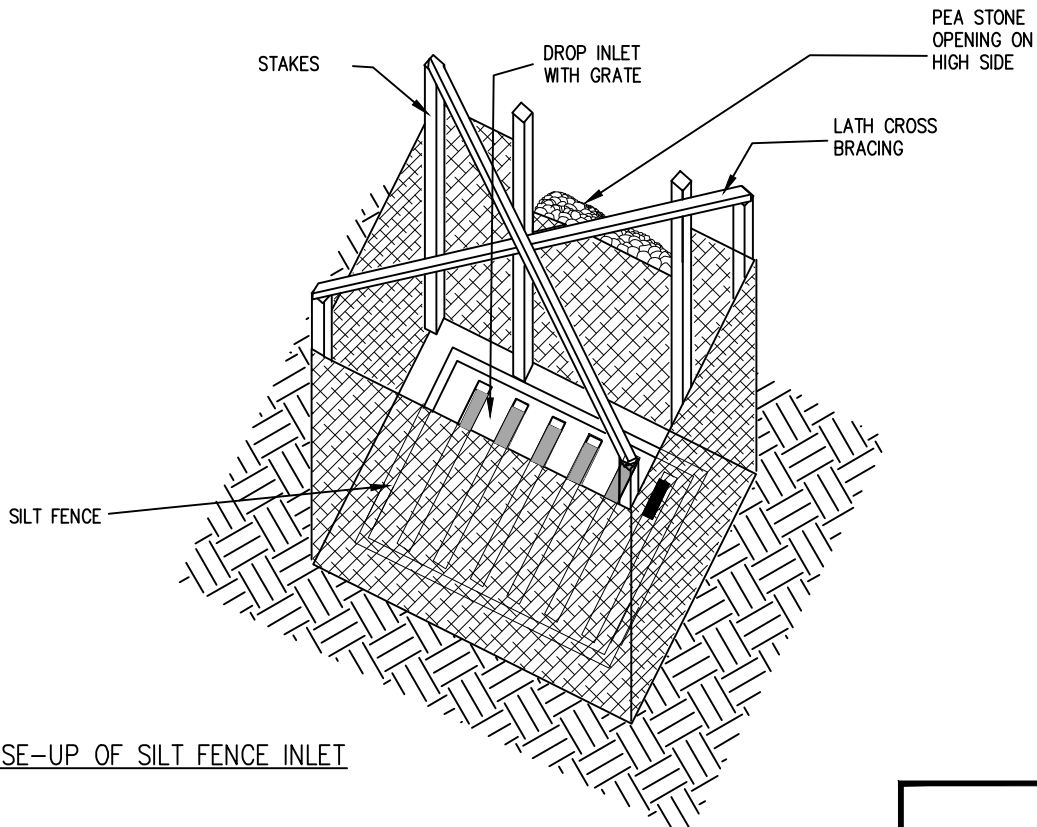

CLOSE-UP OF SILT FENCE INLET

STANDARD SYMBOL



GRAND VALLEY
STATE UNIVERSITY

INLET PROTECTION – FABRIC FENCE

When	<ul style="list-style-type: none">• When sediment-laden stormwater requires treatment before entering a stormwater drainage system.
Why	<ul style="list-style-type: none">• To prevent sediment from entering stormwater systems.
Where	<ul style="list-style-type: none">• Use in or at stormwater inlets, especially at construction sites.
How	<ol style="list-style-type: none">1. Stake filter fence around inlet, making sure it is trenched in well around perimeter of inlet.2. Backfill trench.3. On high side of inlet, create opening in fence between 2 stakes (typically at least 4 to 6" from ground to top of fence).4. Place pea gravel at exterior of silt fence opening to a height of at least 1" above opening.5. A filter fabric bag may be hung inside the inlet, beneath the grate (See Inlet Protection–Fabric Drop).
Maintenance	<ul style="list-style-type: none">• Reconfigure pea stone as needed.• Filter fence may cause temporary ponding and could fail if too much water flows through the area.• Do not use in areas with concentrated flows.• Chance of failure increases if fence is installed incorrectly or if sediment accumulation is not removed.
Limitations	<ul style="list-style-type: none">• Significant flow quantities from large drainage areas may inhibit use.• May impede flows, ponding may occur if not maintained.• Requires frequent maintenance.



S60

INLET PROTECTION-STONE

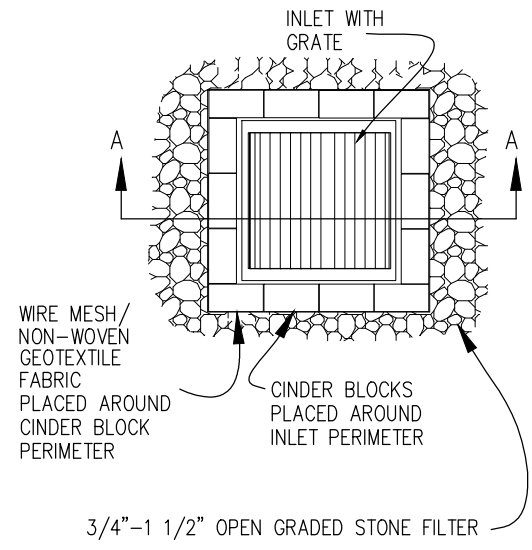

PLAN VIEW

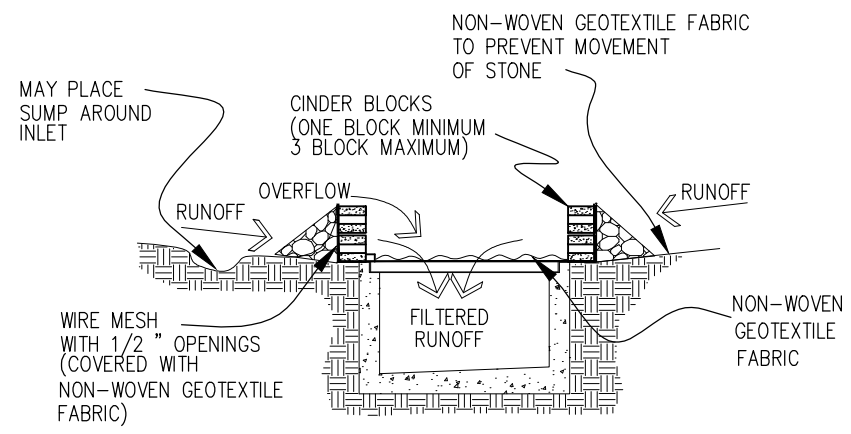

CROSS SECTION A-A

DROP INLET BLOCK AND STONE FILTER

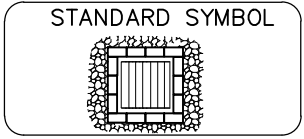

INLET PROTECTION—STONE SPECIFICATIONS

S60

When	<ul style="list-style-type: none">• Filters sedimentation runoff and slows its velocity prior to discharge into storm drainage system.
Why	<ul style="list-style-type: none">• Prevents excessive sediment from entering storm drainage systems prior to permanent stabilization of disturbed areas.
Where	<ul style="list-style-type: none">• Use around stormwater inlets.
How	<ol style="list-style-type: none">1. Place wire mesh with 1/2" openings over the inlet grate, extending a minimum of 1 foot beyond each side of inlet structure.2. Place non-woven geotextile fabric over wire mesh.3. Place concrete blocks lengthwise on their sides in a single row around perimeter of inlet, so that openings face outward, not upward. The ends of adjacent blocks should abut. Height of blocks can vary depending on expected flows, but should be at least 8" and no greater than 24" high.4. Place 1/2" wire mesh and non-woven geotextile fabric over outer openings in block to prevent stone entry.5. Place washed 3/4 - 3" gravel against wire mesh to top of blocks.
Maintenance	<ul style="list-style-type: none">• Should be inspected routinely and after large rain events.• Remove sediment laden stone and replace with new stone.
Limitations	<ul style="list-style-type: none">• Not appropriate in high flow areas.• High maintenance if large amounts of sediment present.• Ponding may occur if device is clogged.



**GRAND VALLEY
STATE UNIVERSITY.**

S61

TURBIDITY CURTAIN

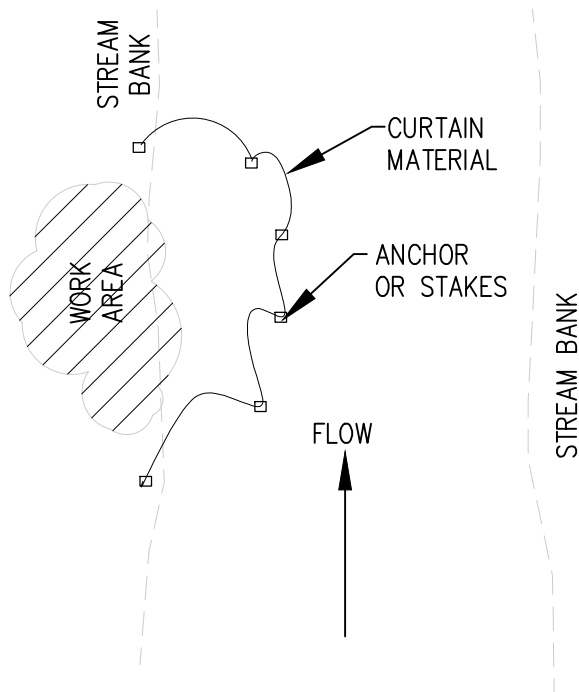

PLAN VIEW

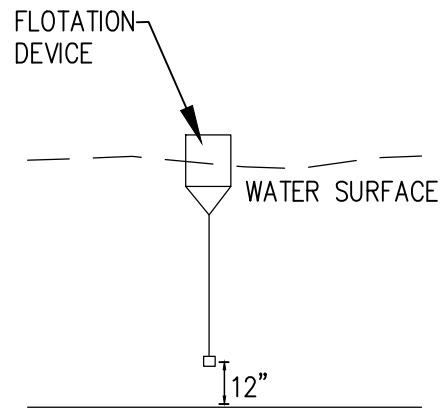

PROFILE

* JOINTS VARY DEPENDING ON TYPE OF WATERBODY AND VELOCITY OF WATERFLOW.

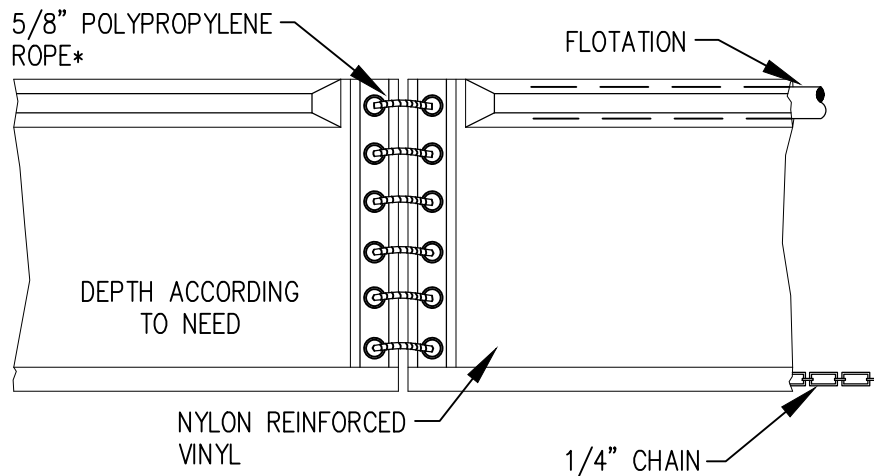

PROFILE - CURTAIN DETAIL

NOTES:
TYPE OF TURBIDITY CURTAIN TO BE DETERMINED BY A QUALIFIED ENGINEER or CPESC.

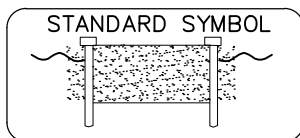

ADAPTED FROM:
AERO-FLO CANVAS PRODUCTS, INC.



TURBIDITY CURTAIN SPECIFICATIONS

- When
- During construction adjacent to a water resource, to contain sediment within the work area when other BMPs cannot be used.
- Why
- To prevent silt-laden runoff from entering adjacent water resources or carrying sediment downstream.
- Where
- Along stream banks, within watercourses and water bodies.
- How
- A qualified engineer or Certified Professional in Erosion and Sediment Control (CPESC) should assess the site conditions to ensure the proper type of turbidity curtain is selected and installed.
 - The curtain will be anchored to the bank and anchors placed at joints where necessary.
 - The lower edge of the barrier should be 12” above the water resource bottom. Flotation devices are used to keep the curtain suspended in the water.
 - The curtain can be used in shallow waters without flotation devices, held by stakes not more than 6 feet apart.
 - Turbidity curtain should be installed parallel, not perpendicular to stream flow (see plan view).
- Maintenance
- Remove sediment buildup as necessary.
 - Frequently check the anchors and joints to ensure they are functioning properly.
- Limitations
- If the turbidity curtain is suspended too close to the stream bed, silt buildup may cause the curtain to be pulled under the surface of the water.
 - Use is limited in areas with high flow velocities or at times when the stream is at peak volume.



Appendix 7

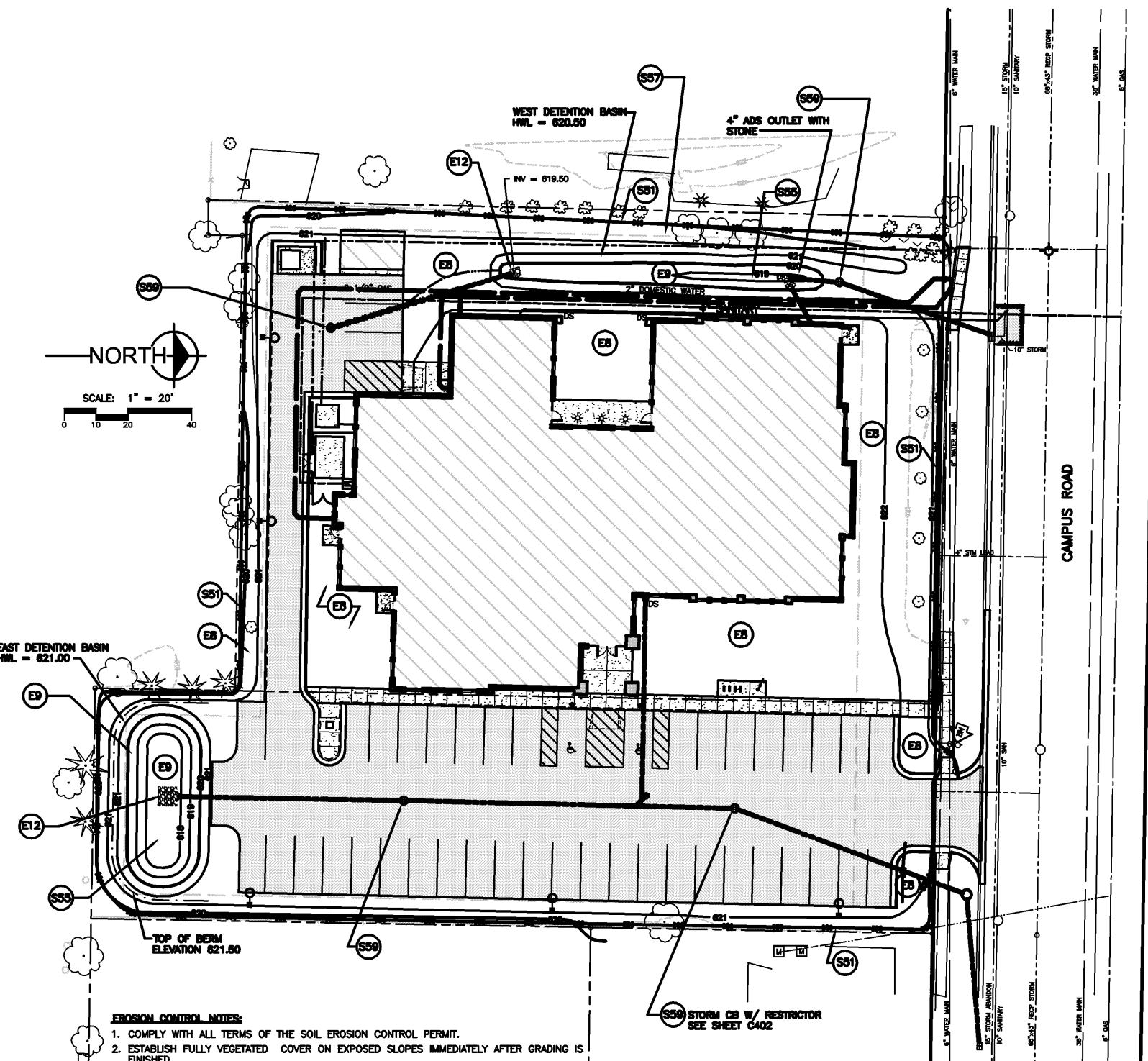
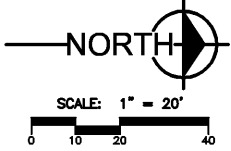

EROSION CONTROL NOTES:

1. COMPLY WITH ALL TERMS OF THE SOIL EROSION CONTROL PERMIT.
2. ESTABLISH FULLY VEGETATED COVER ON EXPOSED SLOPES IMMEDIATELY AFTER GRADING IS FINISHED.
3. MULCH BLANKET SHALL BE USED ON ALL 1 ON 3 SLOPES OR GREATER.

S-E-S-C KEYING SYSTEM

CONSTRUCTION SEQUENCE FOR SOIL EROSION AND SEDIMENTATION CONTROL		SCHEDULE
SEQUENCE	CONTROL MEASURE	
1	INSTALL SILT FENCE AS SHOWN ON PLAN.	
2	CLEAR AND GRUB ONLY THE AREA TO BE DISTURBED BY CONSTRUCTION.	
3	REMOVE TOP SOIL AND STOCKPILE.	
4	GRADE BERM AROUND THE EAST SIDE OF SITE.	
5	EXCAVATE DETENTION BASINS.	
6	TOPSOIL AND SEED.	
7	GRADE OUTLET CHANNEL AND STABILIZE SIDE INLET WITH RIPRAP.	
8	REMOVE SEDIMENT FROM BASINS DURING BUILDING CONSTRUCTION.	
9	RE-SPREAD TOPSOIL AND SEED ALL REMAINING DISTURBED AREAS.	
10	REMOVE SEDIMENT FROM BASINS PRIOR TO FINAL ACCEPTANCE.	

KEY	BEST MANAGEMENT PRACTICES	SYMBOL	WHERE USED
EB	PERMANENT SEEDING		Stabilization method utilized on sites where earth change has been completed (final grading attained).
E9	MULCH BLANKETS		On exposed slopes, newly seeded areas, new ditch bottoms, or areas subject to erosion.
E12	WRAP		Use along shorelines, waterways, or where concentrated flows occur. Slows velocity, reduces sediment load, and reduces erosion.
S51	SILT FENCE		Use adjacent to critical areas, to prevent sediment laden sheet flow from entering these areas.
S55	SEDIMENT BASIN		At the outlet of disturbed areas and at the location of a permanent detention basin.
S57	VEGETATED BUFFER/FILTER STRIP		Use along shorelines, waterways, or other sensitive areas. Slows velocity, reduces sediment load, and reduces erosion in areas of sheet flow.
S59	INLET PROTECTION FABRIC FENCE		Use at stormwater inlets, especially at construction sites.

Appendix 8

REFERENCES

ACF Environmental. Siltsack Drawing/Specifications.

California Department of Transportation. July, 2001. Construction Manual.

California Straw Works. Straw Wattle Specifications.

CALTRANS Stormwater Quality Handbooks. May, 2000. Project Planning and Design Guide.

Colorado Department of Transportation, Project Development Branch. October, 2000. Miscellaneous Items Standard Drawings.

Commonwealth of Pennsylvania, Department of Environmental Protection, Office of Water Management. March, 2000. Erosion and Sediment Pollution Control Program Manual.

Department of Environmental Services, City and County of Honolulu in cooperation with The General Contractors Association of Hawaii. May, 1999. Best Management Practices Manual for Construction Sites in Hawaii.

Idaho Department of Environmental Quality in partnership with Brown and Caldwell, Environmental Engineering and Consulting. August, 2001. Catalog of Stormwater Best Management Practices For Idaho Cities and Counties. 2nd Edition.

Michigan Department of Natural Resources, Surface Water Quality Division. 1992. Guidebook of Best Management Practices for Michigan Watersheds.

Michigan Department of Transportation, Construction and Technology Division. May, 2000. Soil Erosion and Sedimentation Control Manual.

Michigan Department of Transportation. Interim 2003 Standard Specifications for Construction.

North American Green. Mulch Blankets Various Drawings/Specifications.



REFERENCES

Oakland County (Michigan) Soil Erosion Control Manual. 1990.

Ohio Department of Natural Resources. 1987. BMP's for Erosion Control on Logging Jobs.

Presto Products Company. 1998. Solving Channel Protection Problems: Geoweb Cellular Confinement System.

Rhode Island Department of Environmental Management. 1989. Rhode Island Soil Erosion and Sediment Control Handbook.

Silt-Saver, Inc. Silt-Saver Drawing/Specifications.

United States Department of Agriculture Soil Conservation Service. October, 1992. Part 650: Engineering Field Handbook.

United States Department of Agriculture, Natural Resources Conservation Service. January, 1996. Watershed Technology Electronic Catalog.

United States Department of Agriculture, Natural Resources Conservation Service. 1999. Technical Guide. Section IV.

Wisconsin Department of Transportation. January, 2001. Erosion Control Product Acceptability Lists for Multi-modal Applications.



**GRAND VALLEY
STATE UNIVERSITY.**

ACKNOWLEDGEMENTS

Much of the soil erosion control measure information presented in this manual was adapted from the manuals of various states and other resources obtained on the internet. These resources are acknowledged in the References Section of the manual.



**GRAND VALLEY
STATE UNIVERSITY.**