

DIVISION 08 - OPENINGS

08 01 00 OPERATION AND MAINTENANCE OF OPENINGS

1. Specify materials and products that contribute to meeting the requirements of LEED-NC 2.2 EAp2; EA1; MR Credits 4, 5, and 7; EQc4.4; EQc6.1; EQc6.2; and EQc8.1.
2. All multiple leaf exterior doors shall be provided with a keyed removable mullion. Vertical rod panic devices are not permitted.
3. Doors at stairs, departmental office entries, classroom and lab entries and other heavily used locations shall have glass lights. Doors to faculty offices may or may not have glass lights. Confirm requirement with Facilities Planning project manager.
4. Doors should swing against a wall whenever possible. If not possible an overhead stop is required.
5. Use doors, where ever practicable, that are standard height not requiring custom fabrication of door and/or frame. Doors in excess of 7'-2" in height are prohibited unless approved by the University.
6. When door alarms are required on doors, with standard non-electrified hardware configuration, alarmed panic devices shall be used and shall be Von Duprin Series 99 Chexit, or other University approved Von Duprin alarmed panic device per hardware schedule. DETEX devices are not acceptable.
7. When door alarms are required on doors, with electrified card access hardware configuration, alarming mechanism shall be door prop alarms. See Section 28 10 00.
8. The University will furnish BEST 7-pin interchangeable cores. Contractor shall furnish and install 1E74 BEST Cylinders wherever required by the Project. DO NOT INSTALL set screw and plastic disk included with cylinder. See Appendix C, Standard Detail 08.001. The University will install final BEST 7-pin interchangeable cores.

08 10 00 DOORS AND FRAMES

08 12 00 METAL FRAMES

08 12 13 HOLLOW METAL FRAMES

1. Hollow metal frames shall be welded type. Knockdown frames may be permitted, with University approval, for residential buildings only.
2. Frame installation shall conform to ANSI A250.11-2001; Recommended Erection Instructions for Steel frames. SDI web link is: http://www.steeldoor.org/pdfs/A250_11.pdf
3. Frame installation tolerance shall not exceed 1/16" for squareness, plumbness, alignment and twist, in conformance with ANSI A250.11-2001, Annex A. See Figure 1.
4. When installed on masonry coat inside of frame with waterproof coating.
5. When providing knock down frames wrapping around drywall, use anchor adjusting screws and base anchors as shown in Figures 2 and 3, from ANSI A250.11-2001.
6. All exterior hollow metal door frames shall be prepped, with conduit in frame and to location above finished ceiling, and mortar box for strike to accommodate future card access hardware. Additional, these same doors are to be prepped for installation of future "door prop open" alarms, installed as integral part of card access systems.

08 14 00 WOOD DOORS

08 14 16 FLUSH WOOD DOORS

1. Refer to 08 14 23 below for University Standard door finish.
2. If wood veneered finished doors are used, specify minimum AWI Premium Grade door construction and veneer. Use combed rift cut veneer finish.

08 14 23 CLAD WOOD DOORS

1. Doors to be solid core wood with plastic laminate, except where code labeling requires other construction or as otherwise approved in writing by the University.

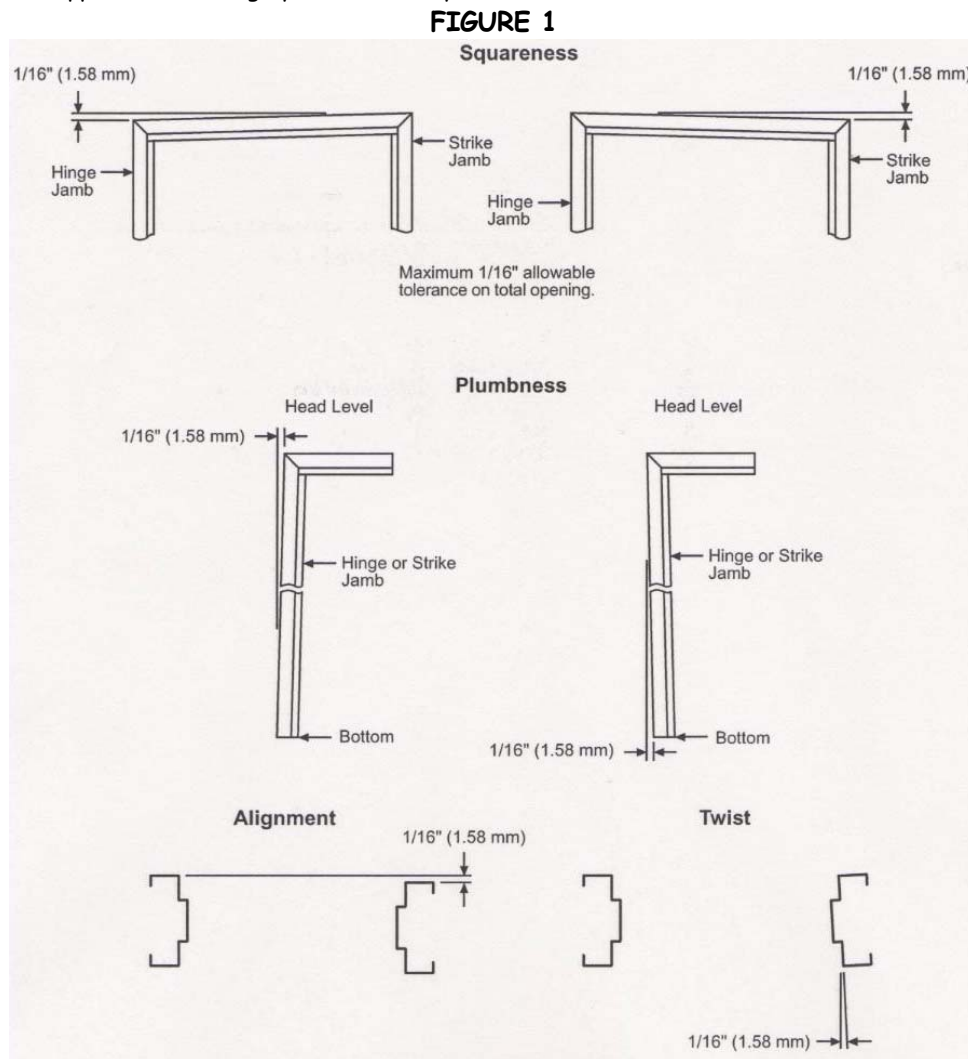

THIS DIAGRAM IS TO BE INCLUDED IN SECTION 08 12 13 OF THE PROJECT MANUAL. ALSO REFERENCE ANSI A250.11-2001 STANDARD.

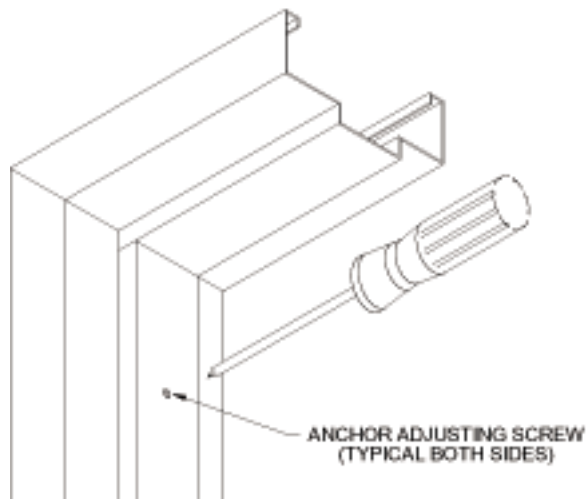

FIGURE 2

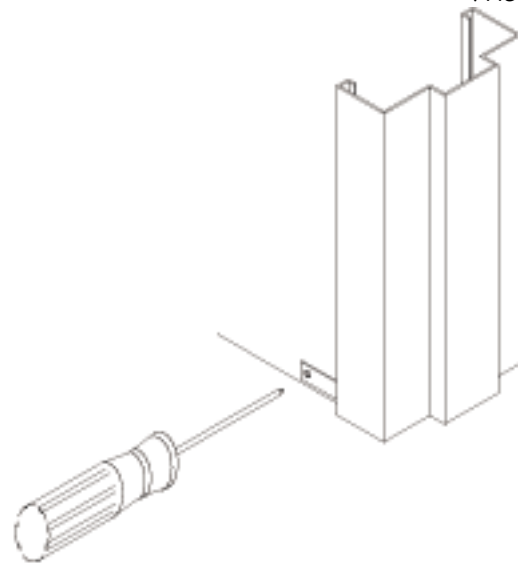

FIGURE 3

08 30 00 SPECIALTY DOORS AND FRAMES

08 31 00 ACCESS DOORS AND PANELS

08 31 13 ACCESS DOORS AND FRAMES

1. All access doors and panels that are accessible off public spaces regardless of what specification division such doors and panels may fall under, shall be provided with BEST 1E74 cylinders prepared to receive the University's BEST interchangeable cores. Access door locations are, but not necessarily limited to, the following:
 - A. Attic or roof access.
 - B. Access to valves.
 - C. Access to fire dampers.
 - D. Access to concealed HVAC equipment.
 - E. Access to all types of concealed controls.
 - F. Access to tub drains.
 - G. Access to elevator sprinkler valve
 - H. Access to Telecom/Data conduit stubs and wire pulls located above inaccessible ceilings. (See Section 27 05 00 for other requirements)
2. Access doors and panels in other non-public spaces including student dorm rooms and apartments can have simple turn latch to secure access panel door.
3. Access panels shall not be obstructed by cabinets, counters, appliances or other building fixtures.

08 33 00 COILING DOORS AND GRILLES

08 33 13 SIDE & OVERHEAD COILING DOORS AND GRILLES

1. All side and overhead coiling doors and grilles shall be prepped for, and furnished with, BEST 1E74 cylinders for locking. This also includes key switches if any of these doors or coils are electrically operated.

08 36 00 PANEL DOORS

08 36 13 SECTIONAL OVERHEAD DOORS

1. All sectional overhead doors shall be prepped for, and furnished with, BEST 1E74 cylinders for locking. This also includes key switches if any of these doors are electrically operated.

08 40 00 ENTRANCES, STOREFRONTS AND CURTAIN WALLS

08 41 00 ENTRANCES AND STOREFRONTS

08 41 13 ALUMINUM-FRAMED ENTRANCES AND STOREFRONTS

1. Exterior glazed doors: Doors to be wide stile heavy duty. Approved manufacturers are Kawneer Tuffline 500, Tubelite Monumental Series, Vistawall Rugged Entry Systems-Rugged WS, and Special-Lite SL-15.
2. Use of vertical rod panic devices, coordinators and other devices are not acceptable.
3. Provide doors, which can accommodate 48-inch wide objects; a removal mullion will accommodate this requirement.
4. All panic devices are to rim type, Von Duprin 99. Doors should swing against a wall whenever possible. If not possible an overhead stop is required.
5. Door height to be approved by the University.
6. Design criteria; thermal break type, accommodate movement due to temperature differential of 180 deg F; wind load 35 psf in, 30 psf out; mullion deflection 1/240 mass; thermal resistance R 2.27; air infiltration 0.06 cfm/sf at 1.57 psf differential pressure; condensation resistance CRF 45.

08 70 00 HARDWARE

08 71 00 DOOR HARDWARE

1. Locksets, panic hardware, door closers and overhead stops will be furnished and installed by the Contractor.. The Contractor will order hardware based upon requirements of the Contract Documents and coordinate hardware as necessary for door and doorframe preparation and any other required coordination with related construction trade work.
2. All other hardware, except BEST cores, not included in the above shall be purchased, furnished and installed by the Contractor.
3. Locksets: The project budget and construction contract should require the provision of all hardware components including cylinder and cores.
4. Acceptable hardware to be Best 35H series, Yale 8700 series, Schlage L9000 series, mortise type with lever handles. Satin chrome or stainless finish. Furnish with Best cylinders that accept 7-pin interchangeable core. The cylinder and cores must be matched with the hardware to assure proper function.
5. The University will furnish, to the Contractor, construction cores and keys for the Contractor's use during construction. The University's key shop representative will remove construction cores when they install final cores. Contractor is responsible for returning all keys, issued to him, to the University.
6. Keying of final cores will be arranged for by Owner and shipped directly to the Owner.
7. Closers: All closers to be surface type through bolted, LCN Smoothee (no substitution). GVSU to approve series. Change method of attachment to allow only through bolting and no screw attachment regardless of door style and/or material.
8. Butts: Ball-bearing type.
9. Panic sets: Von Duprin 99 series
10. Include coat hook in inside of each office door. Could also be wall mounted behind door.

11. Electrical door operators are to be used at building entrances on door used for barrier free accessibility. Coordinate with Electrician for power requirements.
12. Hardware shall be installed by qualified hardware specialist.
13. Punchlist and final acceptance of hardware shall include review of all operations by the warranty holder. A/E to arrange a walk-through with GVSU maintenance staff.
14. Final door layout to be reviewed by GVSU to determine the likelihood of doors being blocked open to support ease of pedestrian movement. Based upon this review, automatic door hold-open device shall be integrated into the hardware system.
15. All dorms/living centers, etc. should have power run to both main entrance doors for possible future use with automatic door openers and separate conduit and box for future card access systems.
16. A hardware pre-installation meeting is required. Representatives of the manufacturer, hardware suppliers, general contractor, and installers are required to attend. Individuals who do not attend this mandatory meeting shall perform no hardware installation.
17. Refer to Section 28 10 00 for Electronic Access.
18. Refer to attached Hardware Master Specification and Schedule in Appendix B for complete requirements.
19. **KEYING:**
 - a) Architect specifies door, frame, and hardware as part of bid package. This includes hinges, closer, controllers, sound control devices, lockset, cylinder, keys and any other components required for a complete and operational door.
 - b) Contract gets awarded to General Contractor. Hardware vendor established.
 - c) GVSU's Project Manager and representative of the Architectural Hardware Department (Keyshop) meet with department heads to discuss keying requirements. These meetings will take place at the beginning of construction.
 - d) Hardware vendor develops hardware schedule shop drawing submittal and provides two (2) copies to the University, in addition to those provided to Architect/Construction Manager.
 - e) BEST sends GVSU staff final keying schedule.
 - f) GVSU provides combined cores and cuts keys for final keying prior to completion of construction, unless otherwise directed by the University.
 - g) All locks to be master-keyed to an existing master-keyed system incorporating the interchangeable core. The existing system is Best.
 - h) All cores are to be of a seven pin design, and shall be instantly interchangeable without adaptation or modification into the core housings for mortise locks, rim locks, cylindrical locks, padlocks, letter file cabinet locks, cabinet door locks, storage cabinet handle locks, and any other types or applications included in the master key system.
 - i) The interchangeable core shall be removable with a control key, which shall have an operating shear line for the control key involving all seven barrels. Such shear line shall be operable with the control key cuts different from the cuts of the grandmaster key, in every barrel cut.
 - j) The grandmaster, master, sub-master, and operating keys shall operate a shear line independent of the control shear line.
 - k) The core shall have the capability of exposing single barrels for recombination (i.e. each barrel shall be independently capped).
 - l) All key blanks shall bear the inscription "Duplication Prohibited."
 - m) This master key system should utilize only one keyway and have provisions for at least 16,000+ individual combinations under the grandmaster key.
 - n) GVSU installs permanent cores (with approval from General Contractor). Keys are made available through Facilities Services Key Department.

08 79 00 HARDWARE ACCESSORIES

08 79 13 KEY STORAGE (KNOX BOX)

1. Provide, at entrance of each building, Knox Box model #4430, recessed mounted (black). Depending on building, additional Knox Box locations may be required at other points of building entrance. Verify additional location requirements with University representative.

08 80 00 GLAZING

08 81 00 GLASS GLAZING

2. Window glass to be insulating type. Outer pane may be coated or tinted. Color of tint shall be reviewed with GVSU during schematic design. Avoid custom glass colors that are not readily available or subject to discontinued use.

END OF SECTION